

estiluz®

www.modulelectro.ru

estiluz®

ESTILUZ, S.A. (Grupo Estiluz)
Carretera d'Ogassa s/n
E-17860 St Joan de les Abadesses
(Girona) Spain
T +34 972 720 125
F +34 972 720 796
estiluz@estiluz.com
www.estiluz.com

DEKA DISTRIBUTION Sarl
(Grupo Estiluz)
2bis, rue Léon Blum, Z.I. des Glaises
91124 Palaiseau cédex
France
T +33 (0) 1 69 32 03 90
F +33 (0) 1 69 32 02 78
estiluzfr@estiluz.com

ESTILUZ GmbH
(Grupo Estiluz)
Pfungstweidstraße 5
D-60316 Frankfurt am Main
Deutschland
T +49 (0) 69 42 69 30 0
F +49 (0) 69 42 69 30 20
estiluzgmbh@estiluz.com

09

NEW

 **MODUL** 

ELECTRO

www.estiluz.com

www.modulelectro.ru

MODUL

ELECTRO

www.modulelectro.ru

Current, youthful and fresh, these are the attributes that describe the new collection launched by Estiluz, celebrating our 40th anniversary.

Our designers, young and experienced, together with Estudi Estiluz have created these state-of-the-art collections utilizing new materials without sacrificing our core values of creativity, quality and elegance.

These products, suitable for contemporary interiors, reflect the new corporate image and modernization of design as shown in our last catalog. This supplement reveals another innovation based on this strategy and a closer relationship with the demanding, but lately more daring public.

Innovation is the new credo that breathes life in our designs. Innovation is the new badge of our new corporate image.

New times, new image, but always the same deep enthusiasm that defines Estiluz.

Junge, frische und aktuelle Designs. So beschreibt man die neue Kollektion, die Estiluz zu seinem 40. Geburtstag präsentiert und sich damit als Avantgardisches Unternehmen verstärkt.

Aktuelle, zeitgemäße Produkte, die unseren neuen Trend verstärken. Ein Trend, der seinen Anfang in unserer neuen Unternehmensidentität und Erneuerung unserer Modelle fand. Diese Erweiterung zeigt einen nächsten Schritt dieser Strategie: Modernität, neue Materialien und die Erfüllung unserer Kundenwünsche.

Unsere neuen Kollektionen atmen den frischen Wind der Innovation und der Modernität.

Innovation, Erneuerung, Modernität ... aber immer dieselbe Freude!

Design jeune, frais et actuel. Ainsi est la nouvelle collection présentée par Estiluz pour son 40ème anniversaire, ce qui nous confirme comme entreprise d'avant garde.

Ses créateurs sont jeunes mais expérimentés et ont créé, avec le Studio Estiluz, ces collections innovantes, utilisant des nouveaux matériaux sans renoncer aux valeurs qui nous identifient : créativité, qualité et élégance.

Ce sont des produits créés pour des espaces actuels qui confortent le changement d'image corporative et la modernisation des produits présentés dans notre catalogue général. Avec cette annexe nous faisons un pas de plus dans cette nouvelle orientation.

Innovation et rénovation sont le nouvel air que respire notre design.

Innovation et rénovation sont les nouveaux signes distinctifs de notre nouvelle image.

Temps nouveaux, nouvelle image mais toujours la même détermination !!

estiluz®

09

NEW

MODUL

ELECTRO

www.modulelectro.ru

Diseños jóvenes, frescos y actuales.

Así es la nueva colección que Estiluz presenta en su 40 aniversario y con la que se reafirma como empresa de vanguardia.

Sus creadores son jóvenes y experimentados diseñadores que, junto al Estudio Estiluz, han creado estas innovadoras colecciones con nuevos materiales sin renunciar a los valores que nos identifican: creatividad, calidad y elegancia.



Son productos diseñados para los espacios actuales que reafirman nuestro nuevo rumbo, iniciado con la nueva imagen corporativa y modernización de productos presentados en el último catálogo. Este anexo desvela un paso más de esta estrategia: producto moderno, diversidad de materiales y mayor aproximación a nuestro público, siempre exigente, pero cada vez más atrevido.

Innovación y modernidad son los aires que respiran nuestras nuevas colecciones.
Innovación, renovación, modernidad... pero siempre la misma ilusión!

linier T-2975

guimeràicinca



 **MODUL** 
ELECTRO
www.modulelectro.ru

poulpe T-2945
oriol ilahona



MODUL
ELECTRO
www.modulelectro.ru

poulpe M-2947

oriol lahona

ELECTRO
www.modulelectro.ru



poulpe P-2949
oriol llahona

MODUL
ELECTRO
www.modulelectro.ru



flamingo P-2929

estudi estiluz



MODUL
ELECTRO

www.modulelectro.ru



pluma P-2959

estudi ribaudí



MODUL

ELECTRO

www.modulelectro.ru

pluma T-2955

estudi ribaudí



 **MODUL** 
ELECTRO

www.modulelectro.ru



YF P-2918

oriol guimerà



MODUL
ELECTRO

www.modulelectro.ru



dot P-2909

serra&delarocha

 **MODUL** 
ELECTRO

www.modulelectro.ru

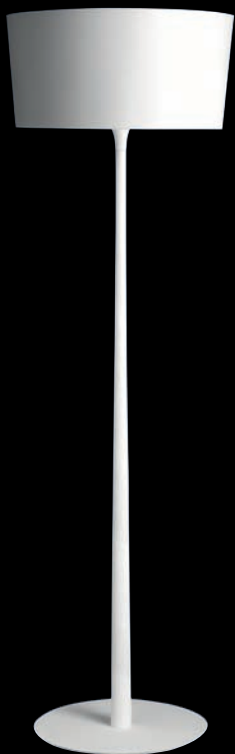

dot T-2905

serra&delarocha

 **MODUL** 
ELECTRO

www.modulelectro.ru

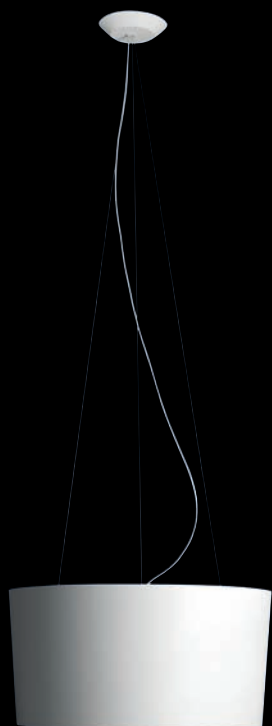

dot t-2902



serra&delarocha



shadow T-2935

jordi vayreda



 **MODUL** 
ELECTRO
www.modulelectro.ru

linier T-2975

guimeràicínca

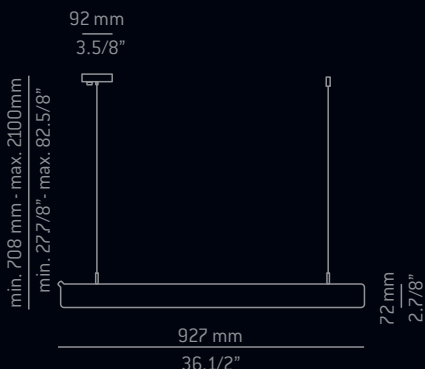

Lámpara de techo con pantalla de espuma rígida de poliuretano. Difusor de metracrilato en la parte inferior.

Pendant made of polyurethane foam. Methacrylate diffuser on the bottom.

Pendelleuchte. Schirm aus Polyurethanschaum. Unterer Kunststoffdiffusor.

Suspension en mousse rigide de polyuréthane. Diffuseur inférieur en méthacrylate.

●● 48RED 74BL 96N GM

El. fluorescent | T5 | 1x39W
universal voltage ballast



poulpe T-2945

oriol llahona



Lámpara de techo con pantalla de espuma rígida de poliuretano. Cristal difusor inferior.

Pendant made of polyurethane foam. Glass diffuser on the bottom.

Pendelleuchte. Schirm aus Polyurethanschaum. Unterer Glasdiffusor.

Suspension en mousse rigide de polyuréthane. Verre diffuseur inférieur.

●● 64NEB 74BL 97GR CV

Inc. | E27 | 150W | 230V

Hal. | BT opal | E27 | 150W | 230V

El. fluorescent | E27 | 20W | 230V



poulpe M-2947

oriol llahona

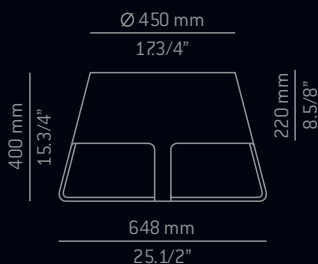

Lámpara de sobremesa de espuma rígida de poliuretano.

Cristal difusor superior.

Regulador de intensidad en el cable eléctrico.

Table lamp made of polyurethane foam.

Glass diffuser on the top. Cord dimmer.

Tischleuchte aus Polyurethanschaum.

Oberer Glasdiffusor. Schnurdimmer.

Lampe à poser en mousse rigide de polyuréthane.

Verre diffuseur supérieur.

Variateur sur le câble alimentation électrique.

●● 64NEB 74BL 97GR CV

Inc. | E27 | 150W | 230V

Hal. | BT opal | E27 | 150W | 230V

El. fluorescent | E27 | 20W | 230V



poulpe P-2949

oriol llahona

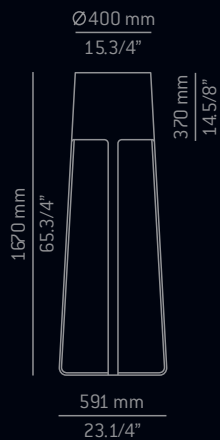

Lámpara de pie de espuma rígida de poliuretano.

Regulador de intensidad en el cable eléctrico.

Floor lamp made of polyurethane foam. Cord dimmer.

Stehleuchte aus Polyurethanschaum. Schnurdimmer.

Lampadaire en mousse rigide de polyuréthane.

Variateur sur le câble alimentation électrique.

●● 64NE B 74BL 97GR CV

Inc. | E27 | 150W | 230V ▽



Hal. | BT opal | E27 | 150W | 230V ▽



El. Fluor. Reg/Dim | E27 | 20W | 230V ▽ ES

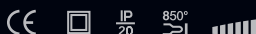

flamingo P-2929

estudi estiluz

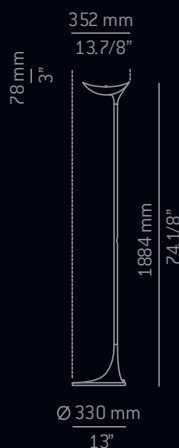

Lámpara de pie con pantalla de espuma rígida de poliuretano. Regulador de intensidad.

Floor lamp made of polyurethane foam. Dimmer.

Stehleuchte aus Polyurethanschaum. Dimmer.

Lampadaire en mousse rigide de polyuréthane. Variateur.

●● 64NE B 74BL 97GR CV

Hal. | R7s | 118mm | 200W | 230V ▽



MODUL
ELECTRO
www.modulelectro.ru



pluma P-2959

estudi ribaudí

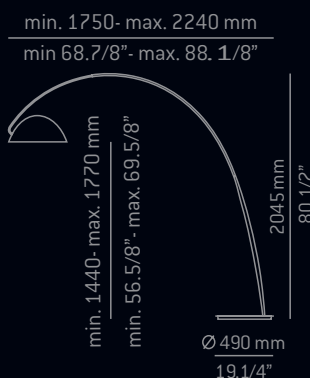

Lámpara de arco metálica con brazo extensible. Pantalla de metacrilato. Regulador de intensidad.

Metallic pendant with adjustable arm. Methacrylate shade.

Cord dimmer.

Metallbogenleuchte. Kunststoffschild.

Reichweite verstellbar. Schnurdimmer.

Lampadaire avec bras extensible métallique et abat-jour en méthacrylate. Variateur sur le câble alimentation électrique.

●● 22CR 26NE 74BL

Pantalla | Shade | Schirm | Abat-jour

● 27BL 64NE B

Inc. opal globe | Ø125mm | E27 | 100W | 230V ▽



El. Fluor. Reg/Dim | E27 | 20W | 230V ▽ ES



pluma T-2955

estudi ribaudí

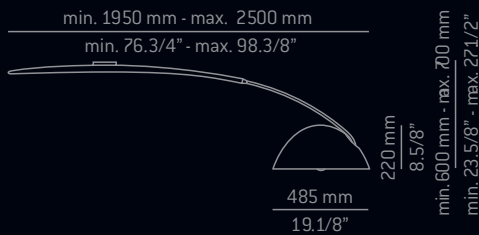





Lámpara de techo metálica con brazo extensible.
Pantalla de metacrilato.
Metallic pendant with adjustable arm. Methacrylate shade.
Metallpendel. Kunststoffschirm. Reichweite verstellbar.
Suspension avec bras extensible métallique et abat-jour en méthacrylate.

●● 22CR 26NE 74BL

Pantalla | Shade | Schirm | Abat-jour

● 27BL 64NE B

Inc. opal globe | Ø125mm | E27 | 100W | 230V  
El. Fluorescent Opal globe | E27 | 20W | 230V  ES 

CE  IP 20  850°

YF P-2918

oriol guimerà

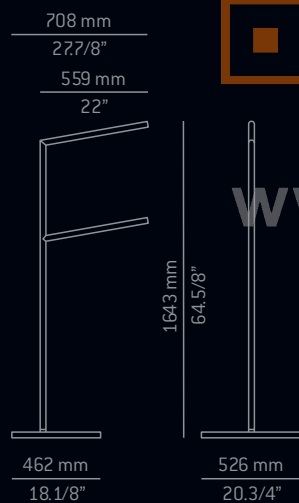



Lámpara metálica con pantallas de policarbonato orientables que permite dirigir el flujo de iluminación. Brazo inferior articulado, con movimiento lateral de 90°. Interruptor de una sola encendida.

Metallic floor lamp with polycarbonate adjustable shades allowing the light to be positioned in the desired direction. Adjustable bottom arm, with a 90° lateral movement. Single switch.

Metallstehleuchte. Beide Schirme aus Polycarbonat und um die eigene Achse drehbar. Unterer Arm bis max. 90° seitlich schwenkbar. Einzelschalter.

Lampadaire métallique avec réflecteurs orientables en polycarbonate pour diriger le flux lumineux. Bras inférieur articulé avec mouvement latéral 90°. Interrupteur on/off.

●● 22CR 56NE M 76BL M

El. fluorescent | T5 | 2x24W | 230V  ES 

CE  IP 20  960°

dot P-2909

serra&delarocha

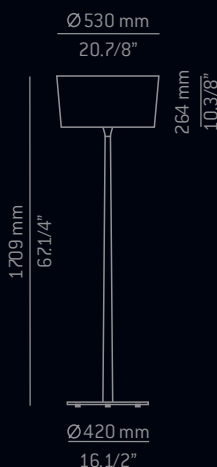





Lámpara de pie con pantalla de Solit (material acrilocerámico, traslúcido) y cristal difusor inferior. Incluye difusor interior con franjas decorativas (uso opcional).

Floor lamp with shade made of Solit (ceramic acrylic material, translucent). Includes internal diffuser with decorative frames (optional use).

Metallstehleuchte. Schirm aus Solit (Acrylkeramikmaterial, Lichtdurchlässiges Material). Unteres Glas weiß satiniert. Innendiffusor mit dekorativen Streifen (optional).

Lampadaire en métal et abat-jour en Solit (matériel acrylo-céramique translucide) et verre diffuseur inférieur. Silhouette décorative intérieure incluse (usage optionnel).

● 72BL M

Inc. | E27 | 2x150W | 230V 
Hal. | BT opal | E27 | 2x150W | 230V 
El. fluorescent | E27 | 2x40W | 230V  ES 

CE  IP 20  850°

acabados

finishes | oberflächen | finitions

dot T-2905

serra&delarocha

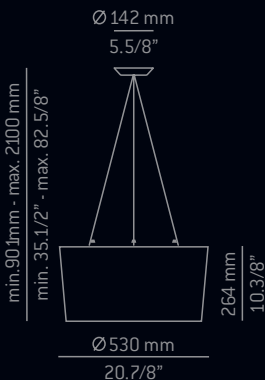

Lámpara de techo con pantalla de Solit (material acrílico-cerámico, traslúcido) y cristal difusor inferior. Incluye difusor interior con franjas decorativas (uso opcional).

Pendant with shade made of Solit (ceramic acrylic material, translucent). Includes internal diffuser with decorative frames (optional use).

Schirm aus Solit (Acrylkeramikmaterial, Lichtdurchlässiges Material). Unteres Glas weiß satiniert.

Innendiffuser mit dekorativen Streifen (optional).

Suspension ave abat-jour en Solit (matériel acrylo-céramique translucide) et verre diffuseur inférieur. Silhouette décorative intérieure incluse (usage optionnel).

● 72BL M

Inc. | E27 | 2x 150W | 230V



Hal. | BT opal | E27 | 2x 150W | 230V



El. fluorescent | E27 | 2x 40W | 230V

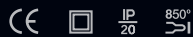

dot t-2902

serra&delarocha

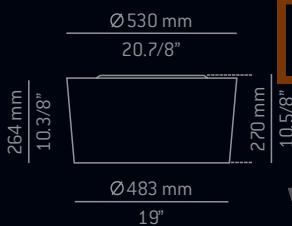

Plafón con pantalla de Solit (material acrílico-cerámico, traslúcido) y cristal difusor inferior.

Flushmount with shade made of Solit (ceramic acrylic material, translucent) and bottom glass diffuser.

Schirm aus Solit (Acrylkeramikmaterial, Lichtdurchlässiges Material). Unteres Glas weiß satiniert.

Plafonnier avec abat-jour en Solit (matériel acrylo-céramique translucide) et verre diffuseur inférieur.

● 72BL M

El. fluorescent | 2G10 | 2x 36W
universal voltage ballast



shadow T-2935

jordi vayreda

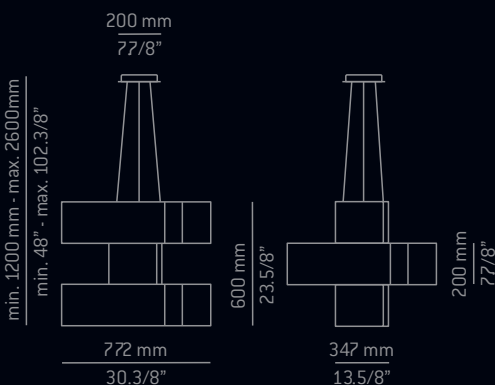

Lámpara de techo metálica con difusor de policarbonato en la parte inferior.

Metallic pendant with polycarbonate diffuser on the bottom.

Metallpendel. Unterer Polycarbonatdiffuser.

Suspension en métal et diffuseur inférieur en polycarbonate.

●● 76BL M 88AN

El. fluorescent | 2G11 | 2x 55W
universal voltage ballast

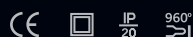

● 22CR

Cromo | Polished chrome
Chrom | Chromé

○ 26NE

Lacado negro | Black lacquer
Mattschwarz lackiert | Laqué noir

● 27BL

Lacado blanco brillante | White lacquer
Weiß glänzend lackiert | Laqué blanc brillant

● 48RED

Rojo | Red | Rot | Rouge

○ 64NE B

Lacado negro brillo | Shiny black
Schwarz glänzend lackiert | Noir Brillant

● 72BL M

Blanco mate (liso) | Matt White (smooth)
Mattweiß (glatt) | Blancmat (lisse)

● 74BL

Lacado blanco brillante | White lacquer
Weiß glänzend lackiert | Laqué blanc brillant

● 76BL M

Blanco mate (rugoso) | Matt White (rough) | Mattweiß (rau)
Blancmat (rugueux)

● 88AN

Arena | Sand | Sand | Sablet

○ 96NGM

Negro goma | Black Matt (gummi)
Schwarz (gummi) | Noir Gomme

● 97GR CV

Gris Cava | Gray Champagne
Gris Champagne | Gris Champagne

pantalla



shade | schrim | abat-jour

● 27BL

Lacado blanco brillante | White lacquer
Weiß glänzend lackiert | Laqué blanc brillant

○ 64N BR

Negro brillante | Shiny black
Schwarz glänzend | Noir Brillant

 **MODUL** 
ELECTRO
www.modulelectro.ru