

la murrina
M U R A N O

Lighting
Veneziani
Classici

Pura magia



Indice Index

Veneziani

Albinoni	
Bach	
Beethoven	
Brahms	
Ca' d'Oro	
Ca' Rezzonico	
Doge	
Fatale	
Lirica	
Manon	
Paganini	
Poesia	
Puccini	
Rossini	
Tosca	
Veneziano	
Violetta	
Vivaldi	

Classici

101	
631	
655	
667	
800	
807	
851	
852	
900	
950	
Bisset	
Caracalla	
Chopin	
Cleopatra	
Cordelia	
Corolla	
Doris	
Ducale	
Duse	
Eloisa	
Evasione	
Favola	
Fenice	
Fiamma	
Fiordaliso	
Flamenco	
Francesina	
Giulietta	
Griffe	
Imperiale	
Isotta	
Kalikantus	
Mozart	
New Look	
Otello	
Ouverture	
Parsifal	
Petalo	
Pierrot	
Preludio	
Princess	
Prisma	
Selene	
Serenata	
Specchi	
Stalattite	
Stone	
Traviata	
Tristano	
Turandot	
Vassoi	



Veneziani

L'esperienza di un'arte antica si esprime attraverso la creazione di ricercate collezioni di luci ispirate allo stile veneziano.

Collezioni uniche che si distinguono per tecnica ed originalità di lavorazione e che arricchiscono contesti dal gusto raffinato.

Forme che si ispirano al passato e lo evocano attraverso la bellezza, la trasparenza ed i colori del vetro, materiale che, abbinato alla fonte luminosa, viene valorizzato ed esprime tutta la sua forza decorativa.

Murano glass inspire a sense of tradition and excellence in refined hand-crafted glass art that creates an exclusive touch in any environment.

The Venetian chandeliers have the distinction of not only maintaining their value and importance, but of being the priceless antiques of the future.

La Murrina, a name that represents centuries of this Italian art and tradition, realizes pieces that remind the past through beauty, transparency and colours of glass, a material that combined with the lighting source acquires value and expresses all its decorative strength.

CA' REZZONICO

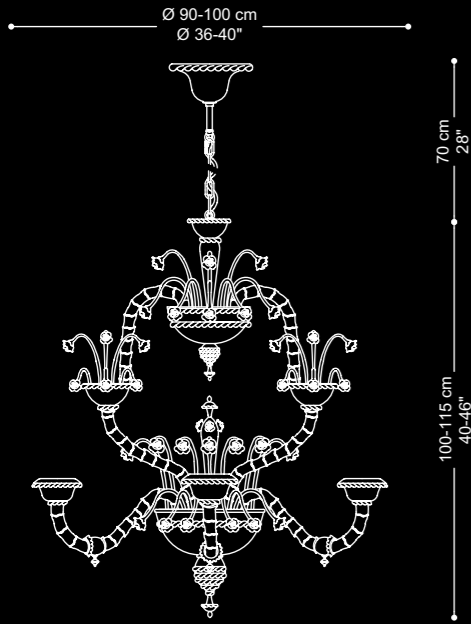

S/ 6-9 | n° x MAX 40W E14 | CE

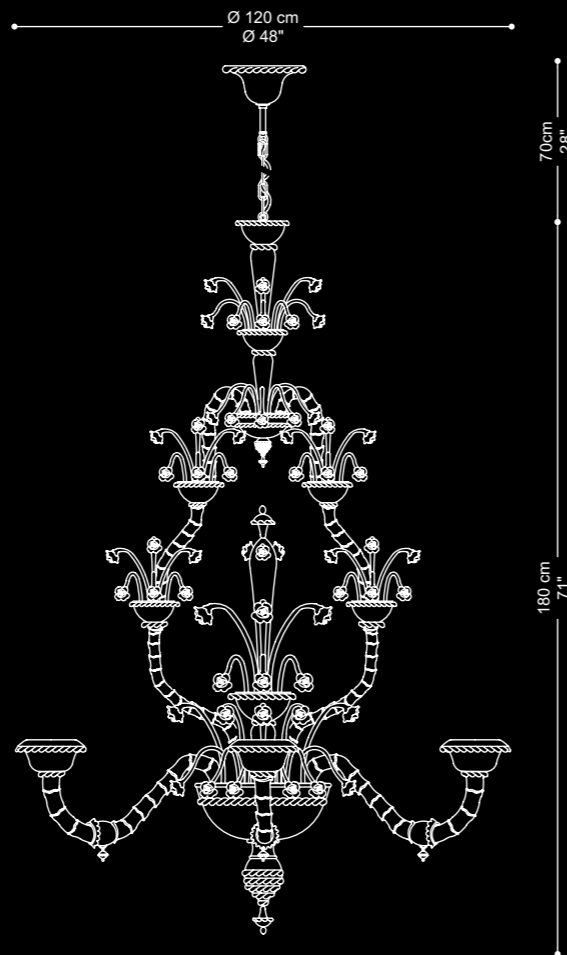

S/ 12 | 12 x MAX 40W E14 | CE

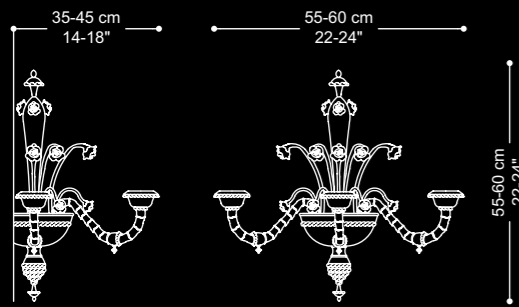

A/ 2-3 | n° x MAX 40W E14 | CE

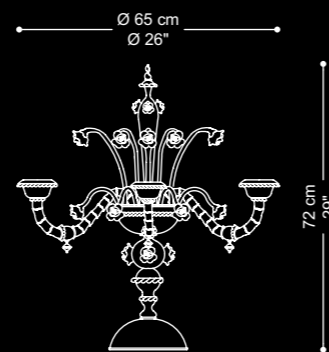

P/ 5 | 5 x MAX 40W E14 | CE

Vetro/Glass



EE



AO



XO



TO

Struttura/Metalwork

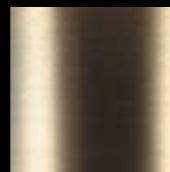

2S



Ca' Rezzonico Multicolor S18



Ca' Rezzonico P5



Ca' Rezzonico S12



Ca' Rezzonico S6



Ca' Rezzonico A2



Ca' Rezzonico S12

ROSSINI

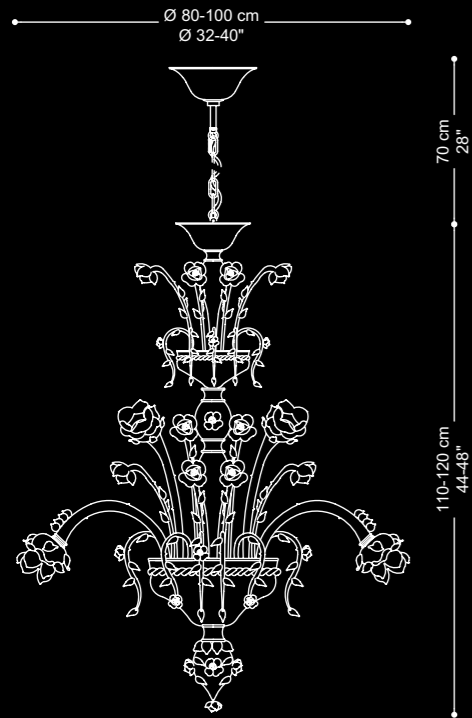

S/ 6-9 | n° x MAX 40W E14 | CE

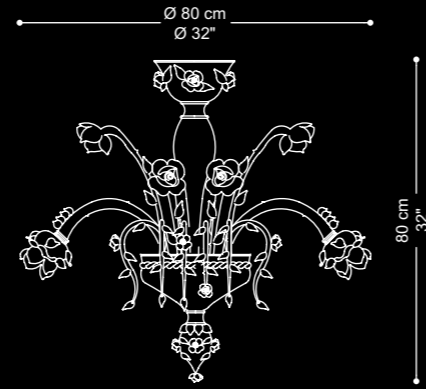

R/ 6 | 6 x MAX 40W E14 | CE

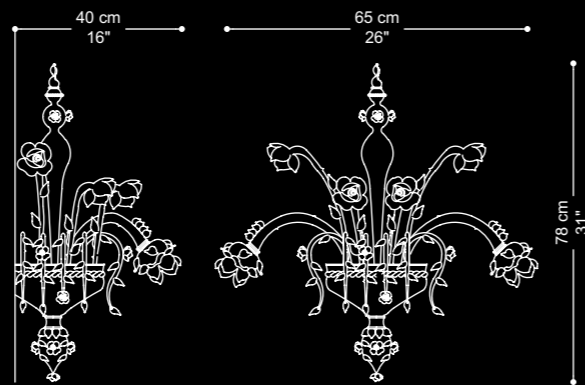

A/ 3 | 3 x MAX 40W E14 | CE

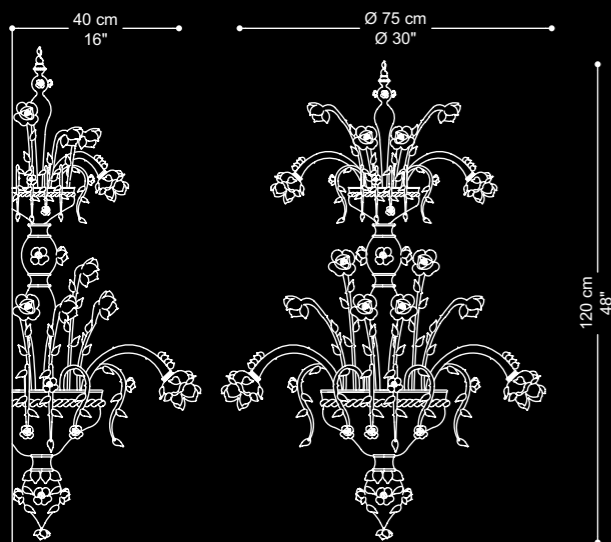

A/ 4+2 | 6 x MAX 40W E14 | CE

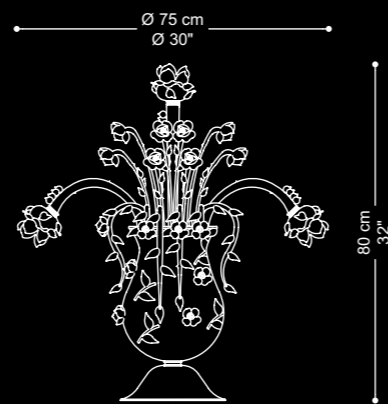

P/ 7 | 7 x MAX 40W E14 | CE

Vetro/Glass



XX

Struttura/Metalwork



2S



Rossini S9



Rossini R6



Rossini P7



Rossini A3



Rossini A4+2

ALBINONI

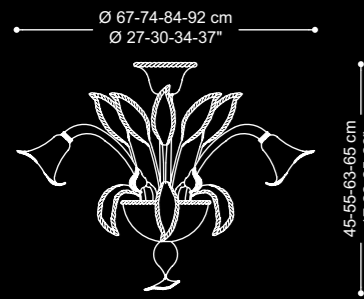

R/ 3-5-6-8 | n° x MAX 40W E14 | CE



S/ 3-5-6-8 | n° x MAX 40W E14 | CE

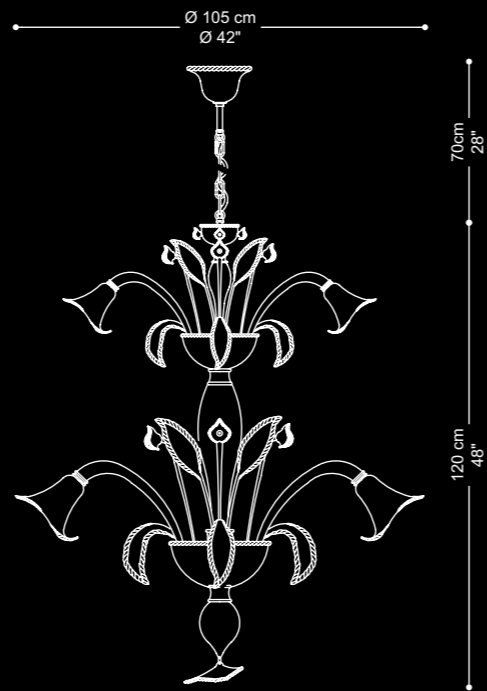

S/ 8+4 | 12 x MAX 40W E14 | CE

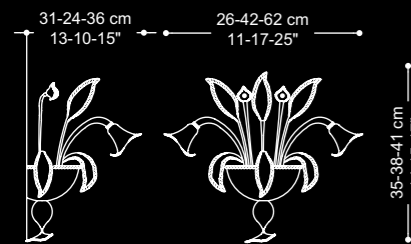

A/ 1-2-3 | n° x MAX 40W E14 | CE

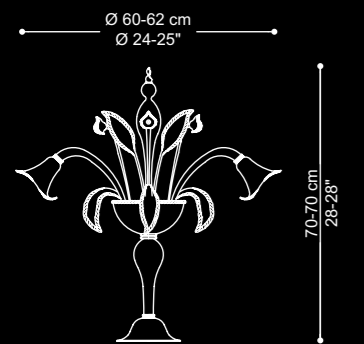

P/ 3-5 | n° x MAX 40W E14 | CE

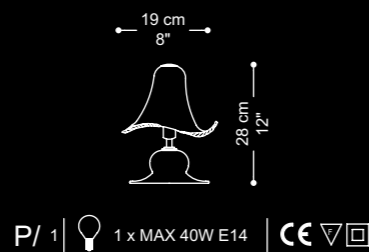

P/ 1 | 1 x MAX 40W E14 | CE

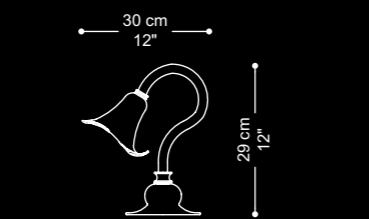

P/ 1L | 1 x MAX 40W E14 | CE

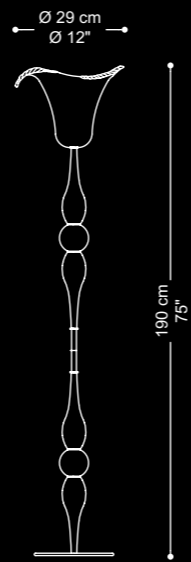

T | 1 x MAX 100W E27 | CE



Vetro/Glass



AO

Struttura/Metalwork

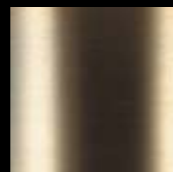

2S

Albinoni S 8+4



Albinoni R6



Albinoni P



Albinoni P1L



Albinoni S6



Albinoni A2



Albinoni T



Albinoni P5

POESIA

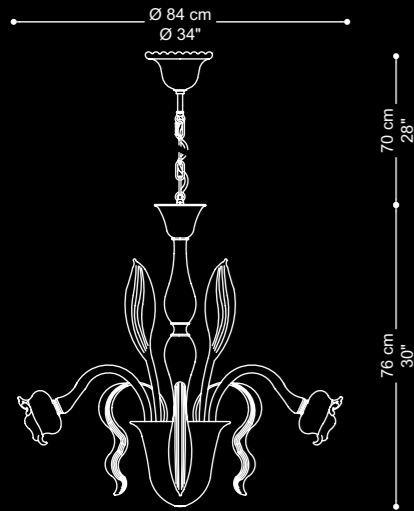

S/ 6 | 6 x MAX 40W E14 | CE

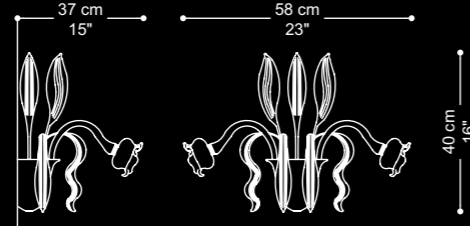

A/ 3 | 3 x MAX 40W E14 | CE

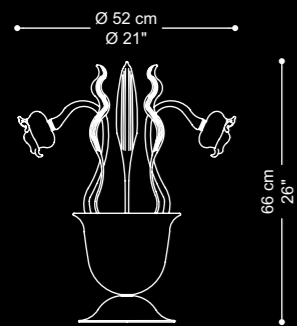

P/ 3 | 3 x MAX 40W E14 | CE

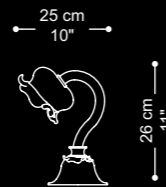

P/ 1L | 1 x MAX 40W E14 | CE

Vetro/Glass



XO

Struttura/Metalwork



2S



Poesia S6



Poesia A3



Poesia P1L



Poesia P3



Poesia S6

VIVALDI

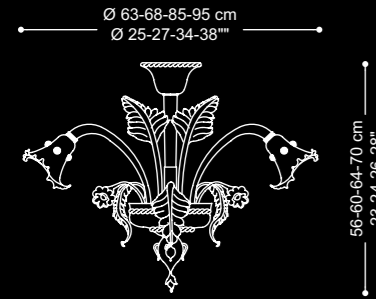

R/ 3-5-6-8 | n° x MAX 40W E14 |

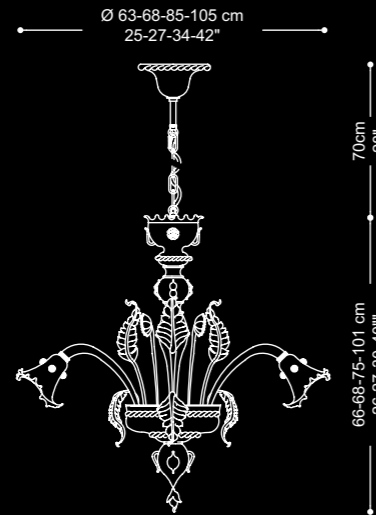

S/ 3-5-6-8 | n° x MAX 40W E14 |

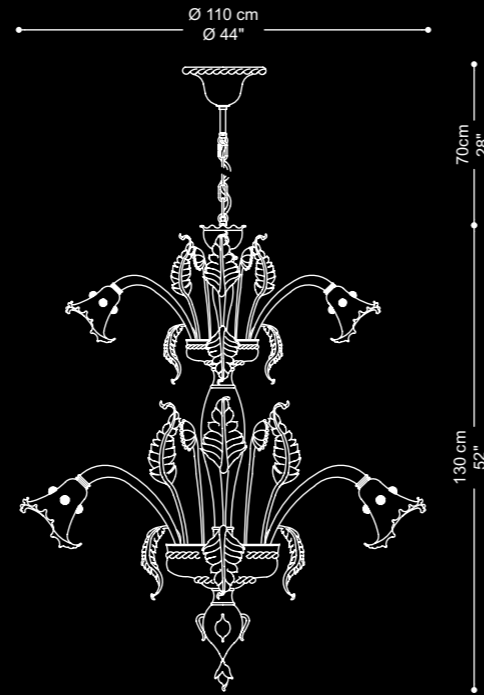

S/ 8+4 | 12 x MAX 40W E14 |

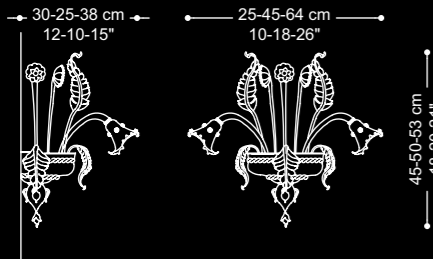

A/ 1-2-3 | n° x MAX 40W E14 |



P/ 1 | 1 x MAX 40W E14 |

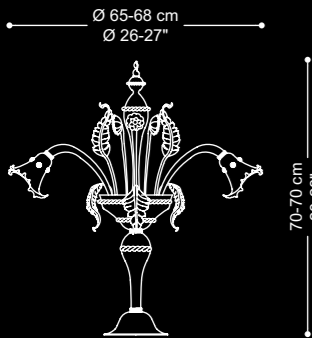

P/ 3-5 | n° x MAX 40W E14 |



P/ 1L | 1 x MAX 40W E14 |

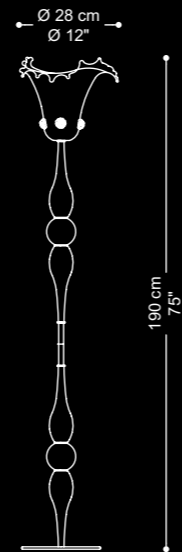

T | 1 x MAX 100W E27 |

Vetro/Glass



AO

XO

RO

AA

Struttura/Metalwork



2S

3S



Vivaldi S 8+4



Vivaldi R5



Vivaldi P



Vivaldi P1L



Vivaldi S6



Vivaldi A3



Vivaldi P5



Vivaldi T



Vivaldi S6

PUCCINI

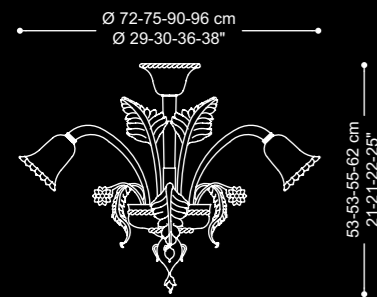

R/ 3-5-6-8 | n° x MAX 40W E14 | CE

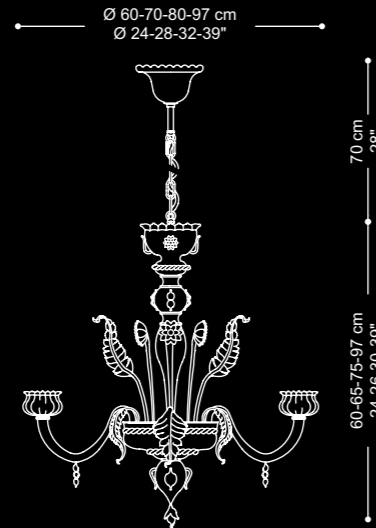

S/ 3-5-6-8 | n° x MAX 40W E14 | CE

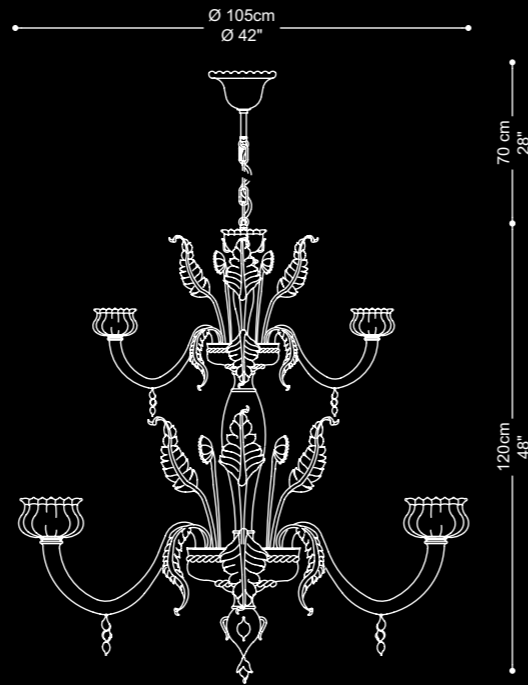

S/ 8+4 | 12 x MAX 40W E14 | CE

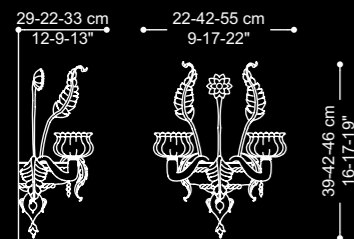

A/ 1-2-3 | n° x MAX 40W E14 | CE

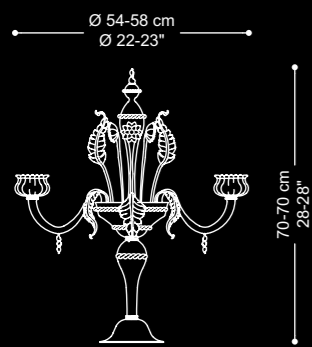

P/ 3-5 | n° x MAX 40W E14 | CE

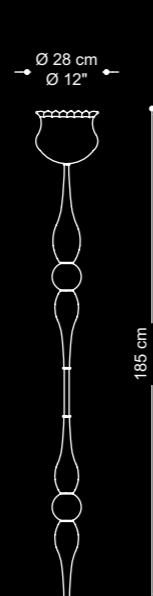

T | 1 x MAX 100W E27 | CE

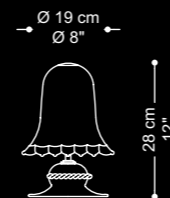

P/ 1 | 1 x MAX 40W E14 | CE

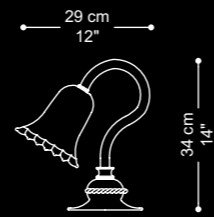

P/ 1L | 1 x MAX 40W E14 | CE

Vetro/Glass



AO

XO

RO

AA

Struttura/Metalwork



2S

3S



Puccini S8+4



Puccini A3



Puccini T



Puccini S6



Puccini P1 P1L



Puccini P5



Puccini S6

CA' D'ORO

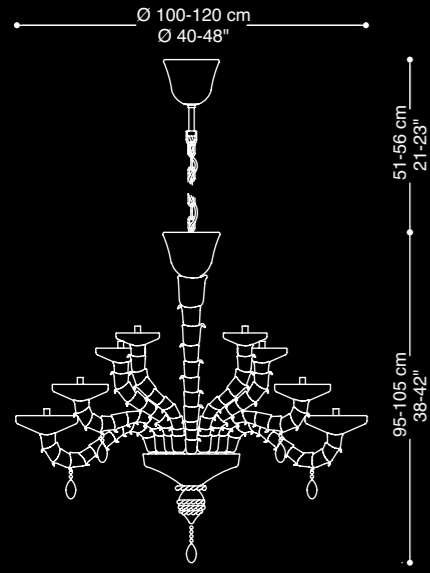

S/12-18 | n° x MAX 40W E14 | CE

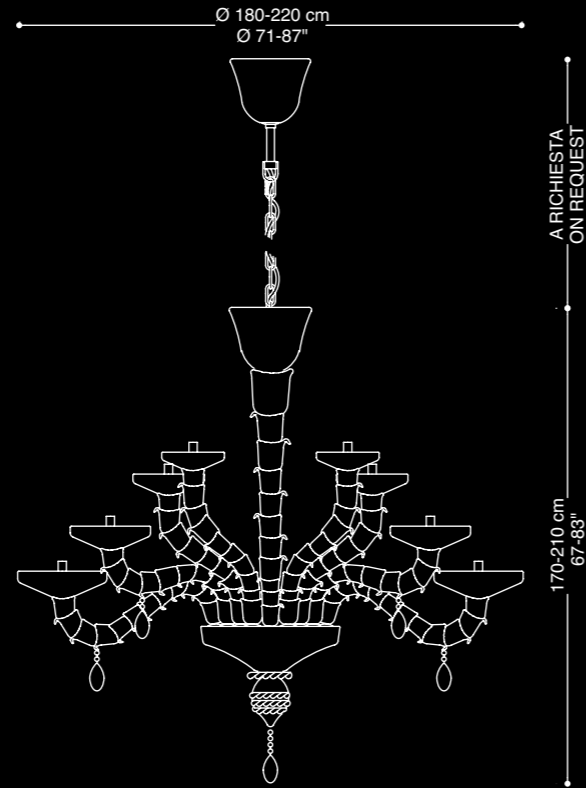

S/30-40 | n° x MAX 40W E14 | CE



Vetro/Glass



QD



QO



PP



YY

Struttura/Metalwork

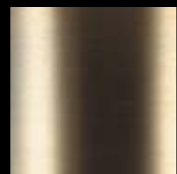

2S

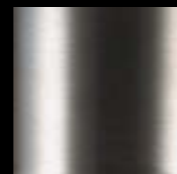

3S

Ca' d'Oro S30

VENEZIANO

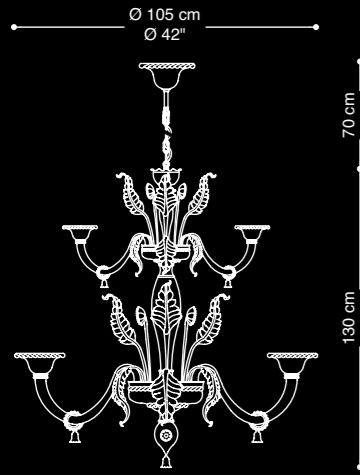

S/ 8+4 | 12 x MAX 40W E14 | CE

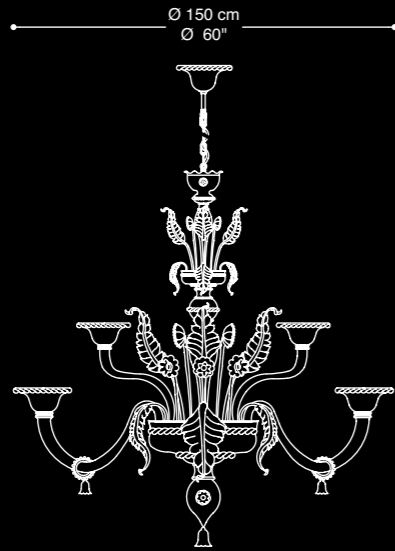

S/ 18 | 18 x MAX 40W E14 | CE

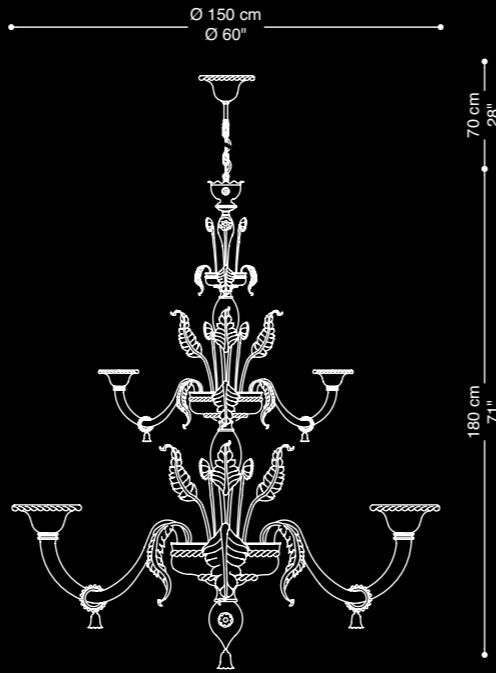

S/ 12+6 | 18 x MAX 40W E14 | CE

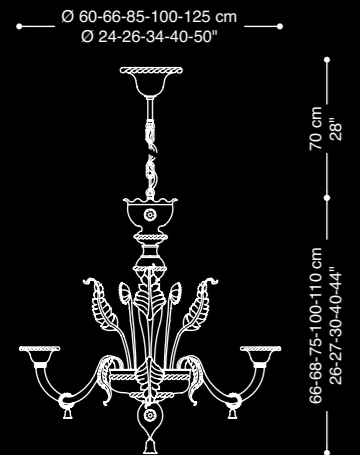

S/ 3-5-6-8-12 | n° x MAX 40W E14 | CE

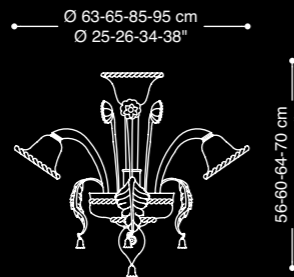

R/ 3-5-6-8 | n° x MAX 40W E14 | CE

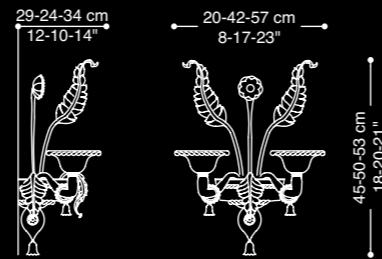

A/ 1-2-3 | n° x MAX 40W E14 | CE

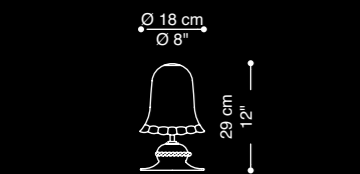

P/ 1 | 1 x MAX 40W E14 | CE

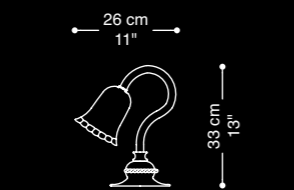

P/ 1L | 1 x MAX 40W E14 | CE

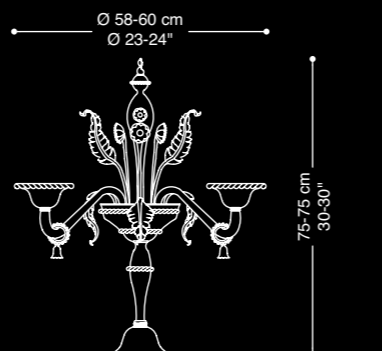

P/ 3-5 | n° x MAX 40W E14 | CE

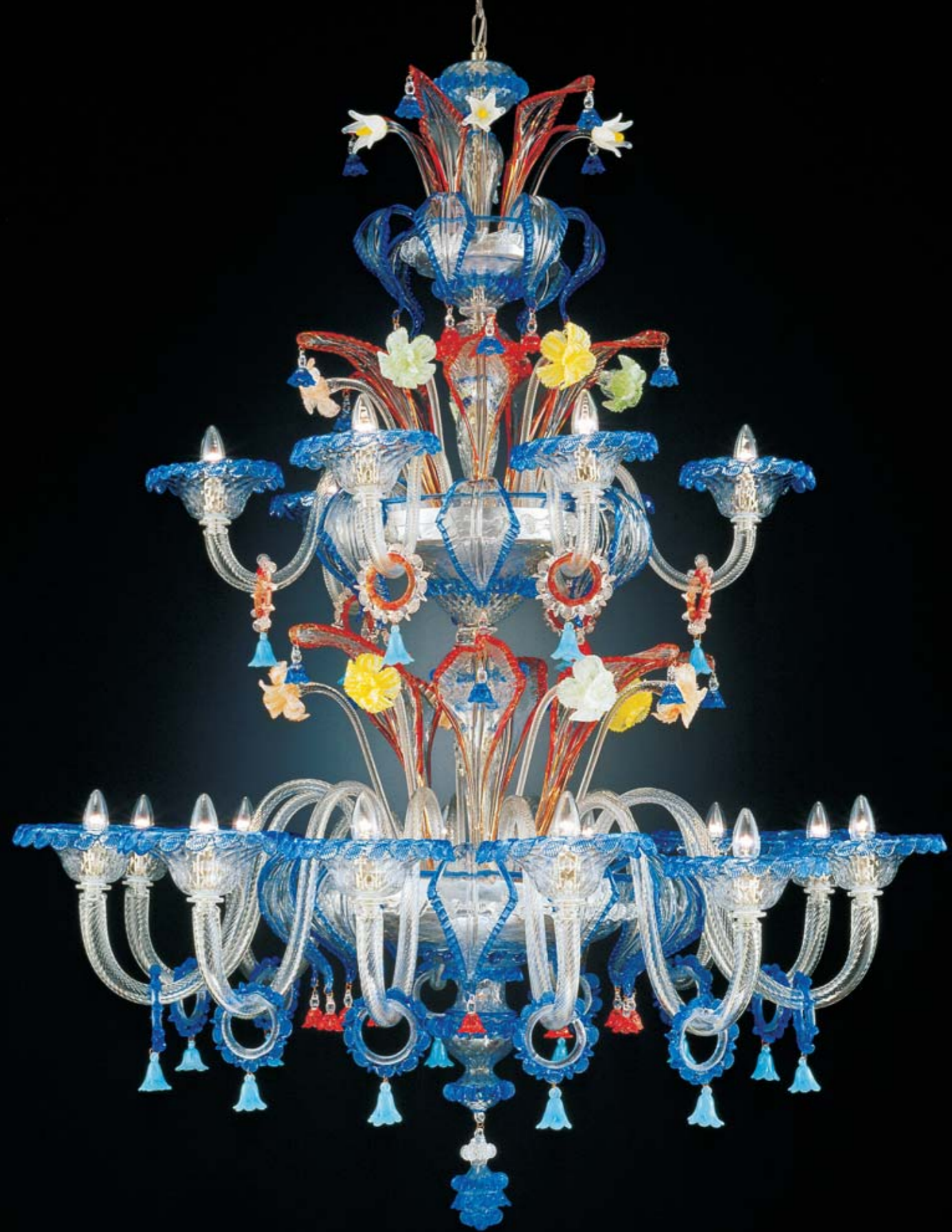

Vetro/Glass



NO



EE

Struttura/Metalwork

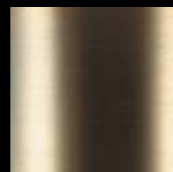

2S

Veneziano S12+6



Veneziano A2



Veneziano P3



Veneziano P1L



Veneziano P1



Veneziano S8

BRAHMS

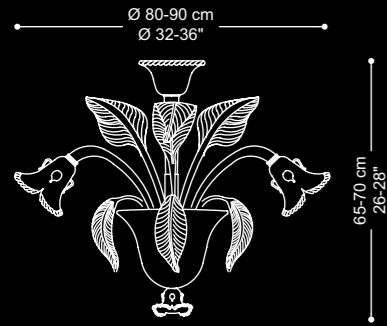

R/ 6-8 | n° x MAX 40W E14 | CE

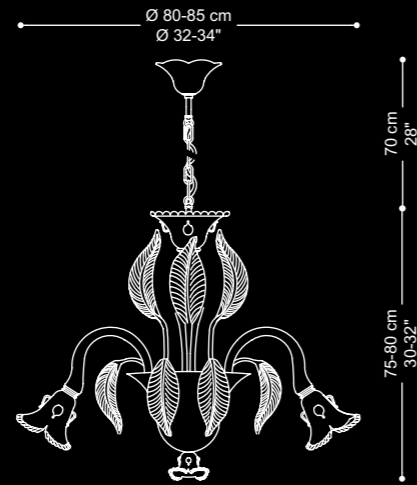

S/ 6-8 | n° x MAX 40W E14 | CE

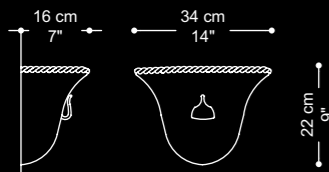

A | 1 x MAX 100W E27 | CE

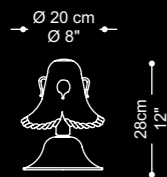

P/ 1 | 1 x MAX 40W E14 | CE

Vetro/Glass



AN

NO

Struttura/Metalwork

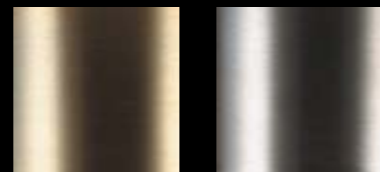

2S

3S



Brahms S6



Brahms R6



Brahms S6



Brahms A



Brahms P

FATALE

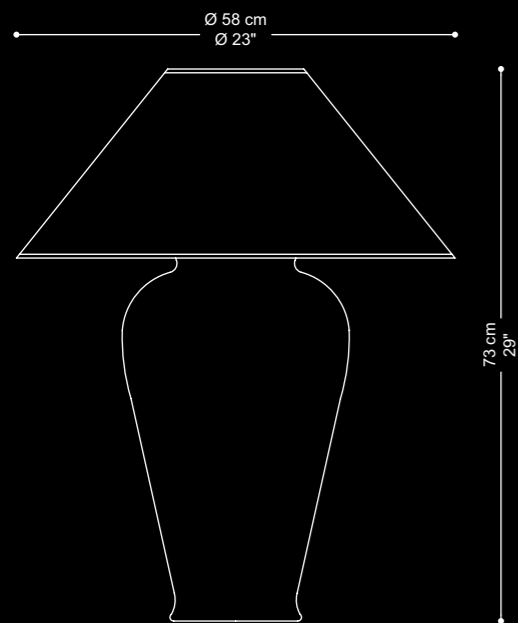

L | 1 x MAX 100W E27 + 1 x MAX 40W E14 | CE

Vetro/Glass



AN

Struttura/Metalwork



2S



Fatale L

BEETHOVEN

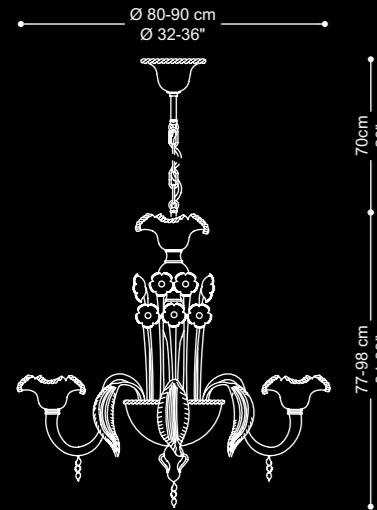

S/ 6-8 | n° x MAX 40W E14 |

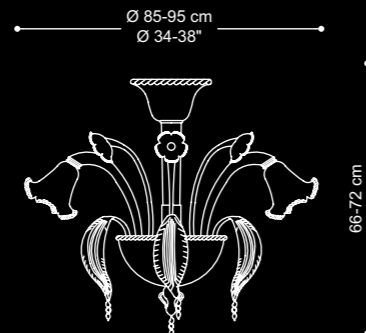

R/ 6-8 | n° x MAX 40W E14 |

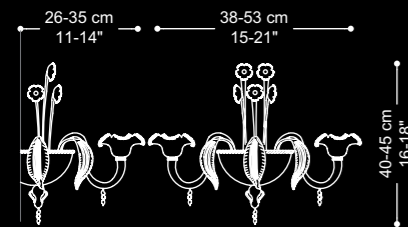

A/ 2-3 | n° x MAX 40W E14 |

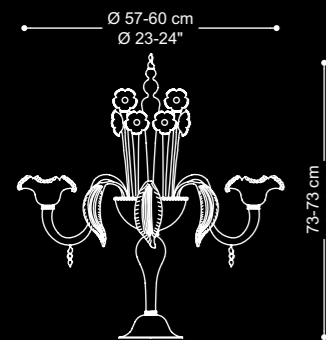

P/ 3-5 | n° x MAX 40W E14 |



P/ 1 | 1 x MAX 40W E14 |

Vetro/Glass



AO

Struttura/Metalwork



2S



Beethoven S6



Beethoven R6



Beethoven P5



Beethoven A2



Beethoven P1



Beethoven S6

LIRICA

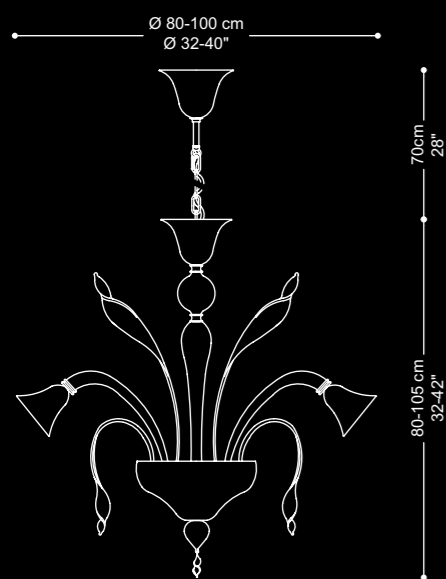

S/ 6-8 | n° x 40W E14 | CE

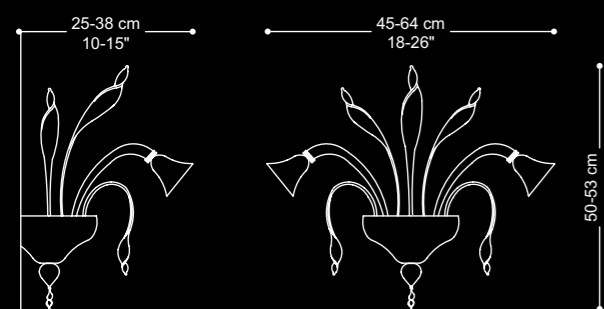

A/ 2-3 | n° x MAX 40W E14 | CE

Vetro/Glass



AA

Struttura/Metalwork

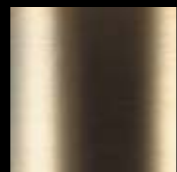

2S



Lirica S6

PAGANINI

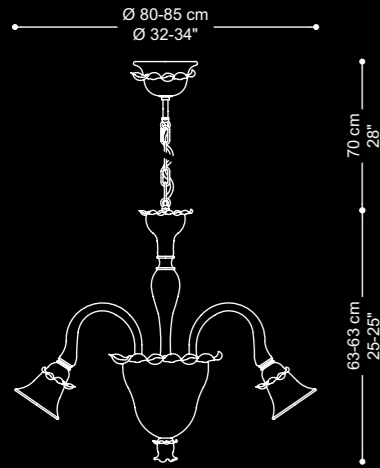

S/ 6-8 | n° x MAX 40W E14 |

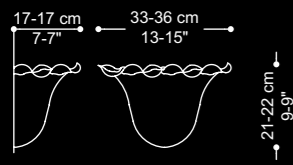

A/ 33-36 | 2 x MAX 40W E14 |

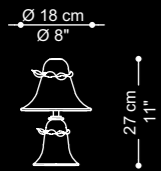

P/ 1 | 1 x MAX 40W E14 |

Vetro/Glass



AO

Struttura/Metalwork



2S



Paganini S8



Paganini A



Paganini P1

BACH

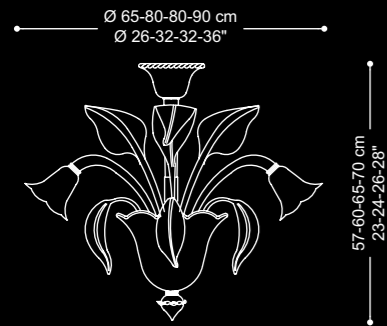

R/ 3-5-6-8 | n° x MAX 40W E14 |

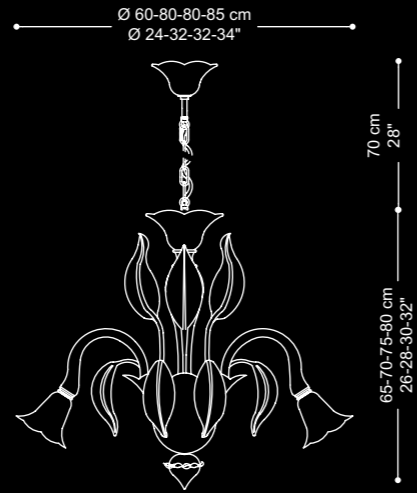

S/ 3-5-6-8 | n° x MAX 40W E14 |

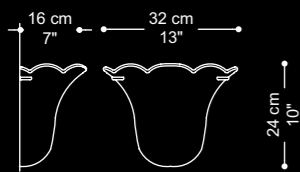

A | 1 x MAX 100W E27 |

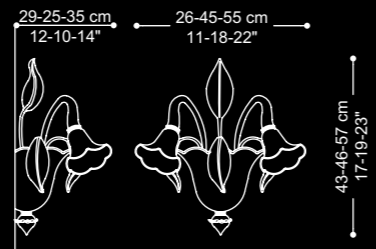

A/ 1-2-3 | n° x MAX 40W E14 |

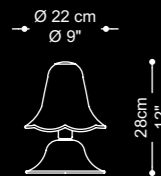

P/ 1 | 1 x MAX 40W E14 |

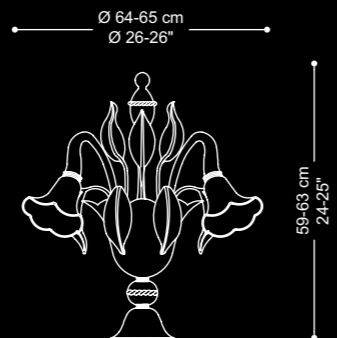

P/ 3-5 | n° x MAX 40W E14 |

Vetro/Glass



AB

Struttura/Metalwork

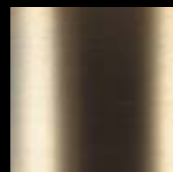

2S



Bach S6



Bach R5



Bach A2



Bach A



Bach P



Bach P3

DOGE

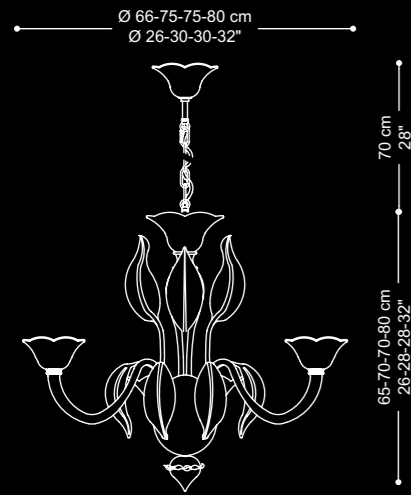

S/ 3-5-6-8 | n° x MAX 40W E14 | CE

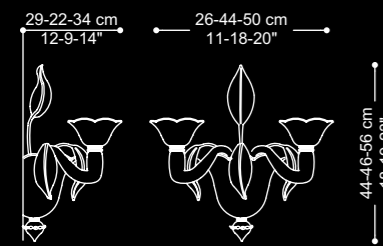

A/ 1-2-3 | n° x MAX 40W E14 | CE

Vetro/Glass



AB

Struttura/Metalwork

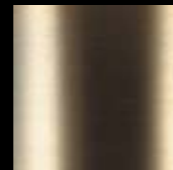

2S



Doge S6



Doge A3

TOSCA

VIOLETTA

TOSCA

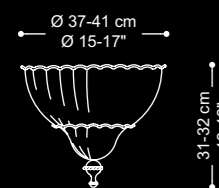

R | 3 x MAX 40W E14 | CE

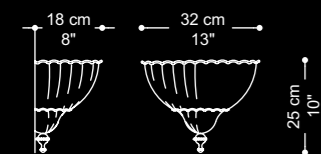

A | 2 x MAX 40W E14 | CE

VIOLETTA

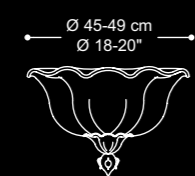

R | 3 x MAX 40W E14 | CE

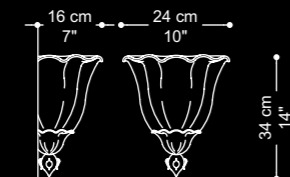

A | 2 x MAX 40W E14 | CE

Vetro/Glass



AO

XO

RO

AA

Struttura/Metalwork

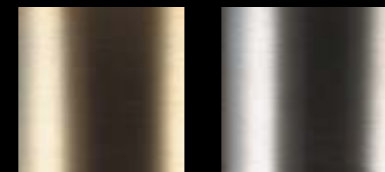

2S

3S



Tosca R



Tosca A



Violetta R



Violetta A

MANON

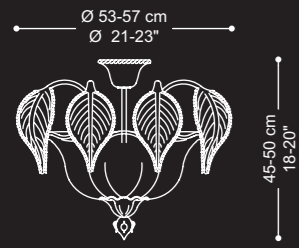

R | 3 x MAX 40W E14 | CE

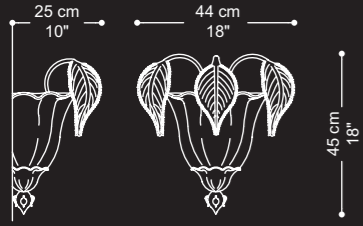

A | 2 x MAX 40W E14 | CE



Manon R



Manon A

Vetro/Glass

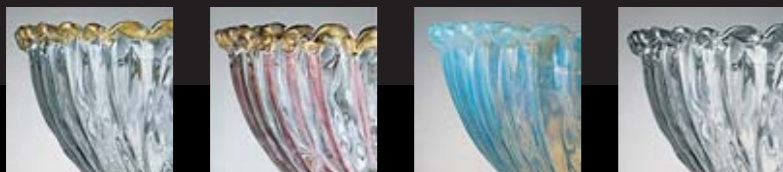

AO

XO

RO

AA

Struttura/Metalwork

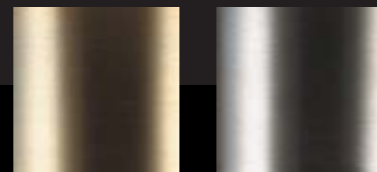

2S

3S



Classici

Le forme sono quelle antiche, spogliate dei motivi decorativi più tipici della tradizione veneziana, e rielaborate con linee più sobrie e pulite.

La purezza e la trasparenza del vetro acquisiscono grande valore e la qualità della lavorazione viene esaltata dalla linearità delle forme e dall'eleganza del prodotto.

Arte e passione si fondono dando vita a prodotti il cui stile, pur non seguendo le tendenze più innovative, si rinnova continuamente nel corso del tempo.

The shapes are the ancient ones, deprived of the decorative motives more typical of the Venetian tradition, and redesigned with more sober and straight shapes.

The purity and the transparency of the glass improve its value and the quality of the manufacturing is exalted by the linearity of the shapes and the elegance of the product.

Art and passion combined together giving life to products whose style, even if does not follow the most innovative tendencies, remains timeless.

FLAMENCO

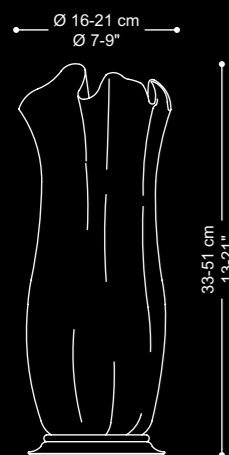

P/ Ø 16 | 1 x MAX 40W E14
Ø 21 | 1 x MAX 100W E27

CE



Vetro/Glass



YY



DD

Struttura/Metalwork

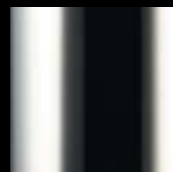

3L

Flamenco P

SELENE

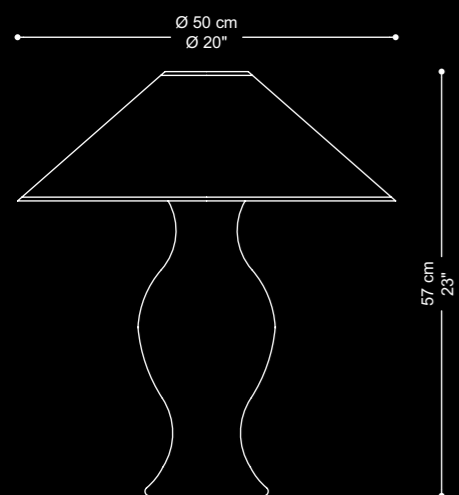

L | 1 x MAX 100W E27 + 1 x MAX 40W E14 | CE



Vetro/Glass



CC

DD

Struttura/Metalwork



2S

Selene L

PRINCESS

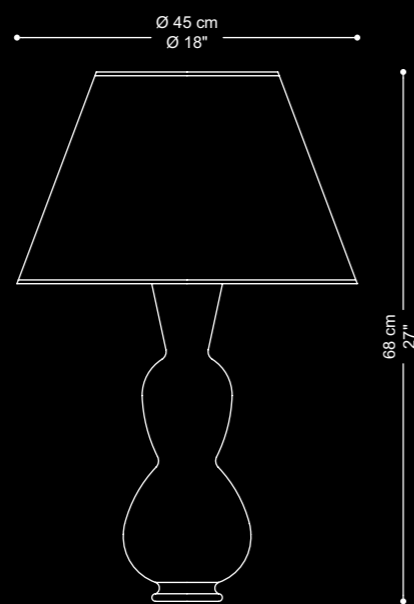
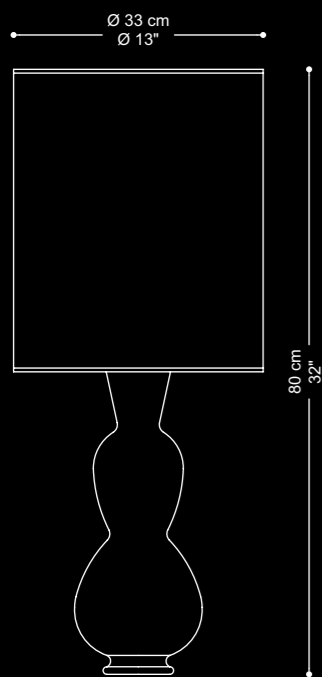

L / TESO | 1 x MAX 100W E27 | CE

L / PAGODA | 1 x MAX 100W E27 | CE

Vetro/Glass



CN

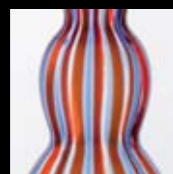

YN

Struttura/Metalwork

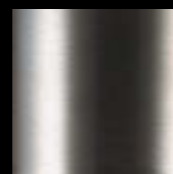

3S



Princess L

IMPERIALE

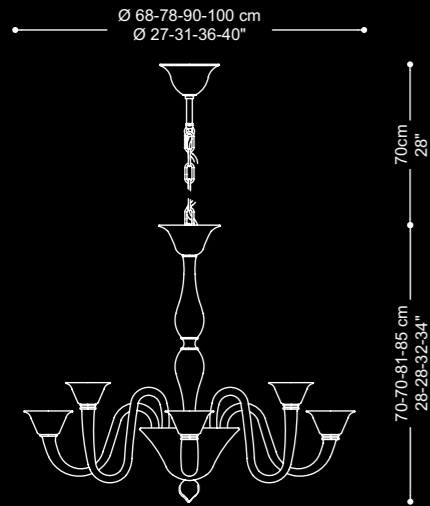

S/ 6-8-10-12 | n° x MAX 40W E14 | CE

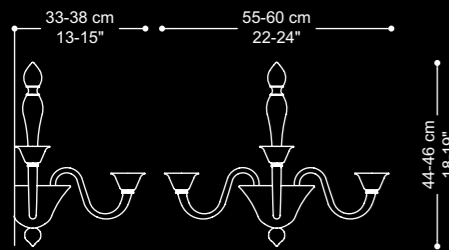

A/ 3-5 | n° x MAX 40W E14 | CE

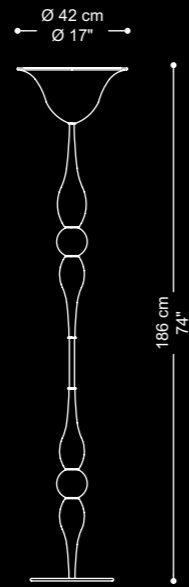

T | 1 x MAX 100W E27 | CE

Vetro/Glass



AA

Struttura/Metalwork

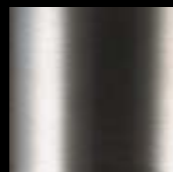

3S



Imperiale S10



Imperiale A3



Imperiale S6

Imperiale T

NEW LOOK

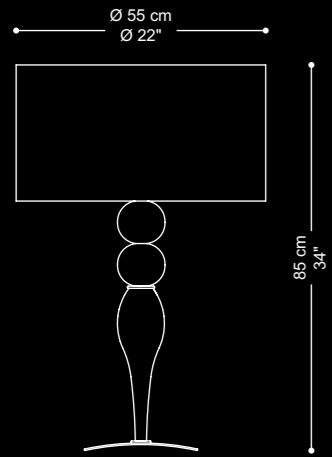

P/ 55 | 1 x MAX 100W E27 | CE

Vetro/Glass



AS

Struttura/Metalwork



3S



New Look

[Torna all'indice](#)
[Back to index](#)

PRELUDIO

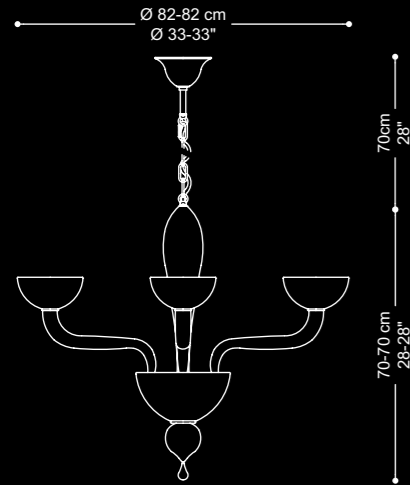

S/ 6-8 | n° x MAX 40W E14 | CE

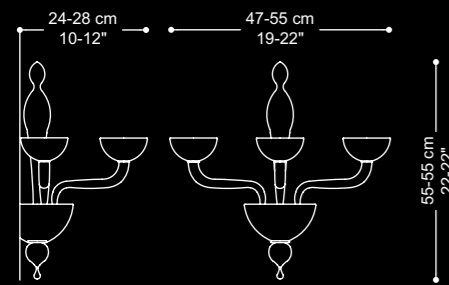

A/ 2-3 | n° x MAX 40W E14 | CE

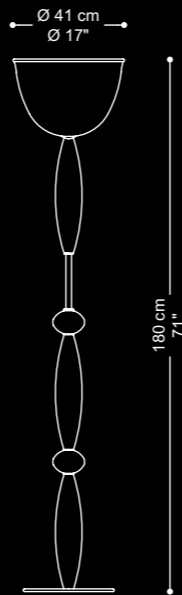
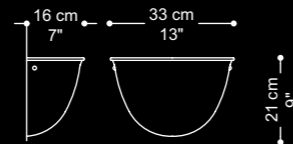

A/ AL 33 | 1 x MAX 100W AL R7S | CE

T | 1 x MAX 100W E27 | CE

Vetro/Glass



II

Struttura/Metalwork



2S



Preludio S8



Preludio T



Preludio A



Preludio S8

FRANCESINA

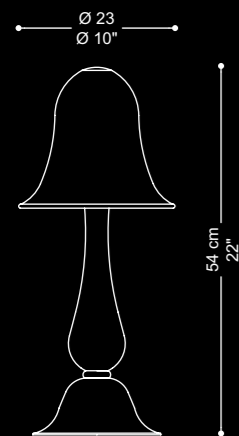

P | 1 x MAX 40W E14 | CE

Vetro/Glass



II

Struttura/Metalwork

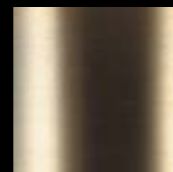

2S



Francesina P

CLEOPATRA

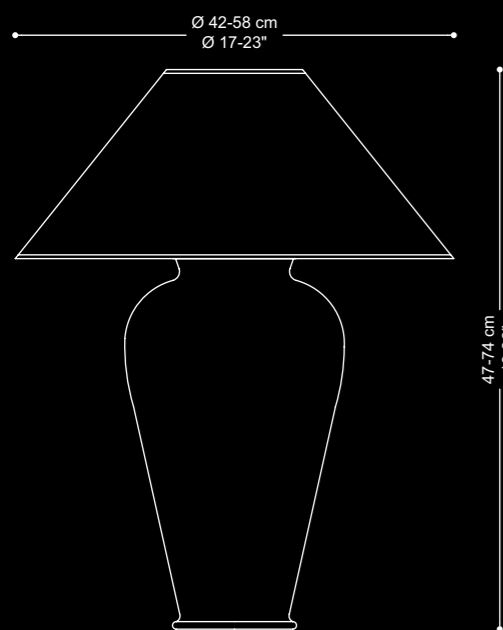

L / $\varnothing 42$ | 1 x MAX 100W E27 + 1 x MAX 40W E14 | 

L / $\varnothing 58$ | 1 x MAX 100W E27 + 1 x MAX 40W E14



Vetro/Glass



10

Struttura/Metalwork



2S

Cleopatra L

OUVERTURE

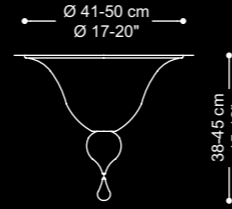
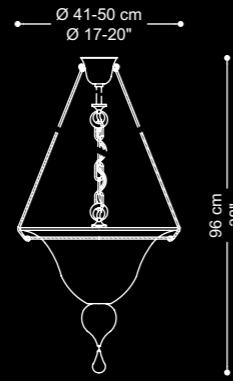
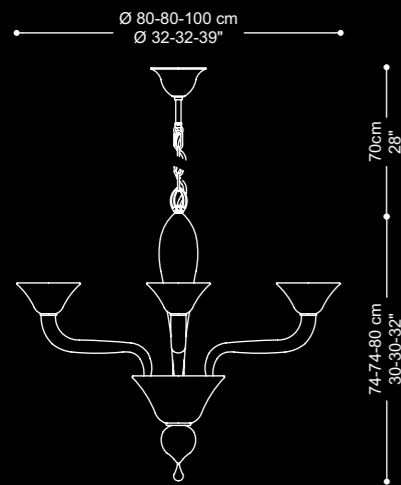

R/ Ø 41 | 3 x MAX 40W E14
 Ø 50 | 3 x MAX 40W E14

S/ Ø 41 | 1 x MAX 100W E27
 Ø 50 | 1 x MAX 100W E27

S/ 6-8-10 | n° x MAX 40W E14

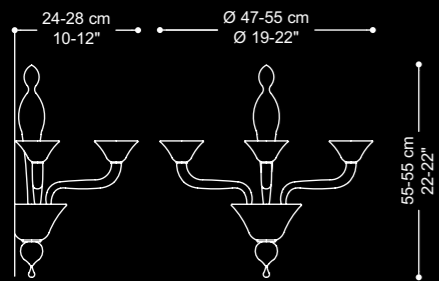

A/ 2-3 | n° x MAX 40W E14

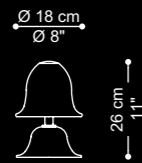
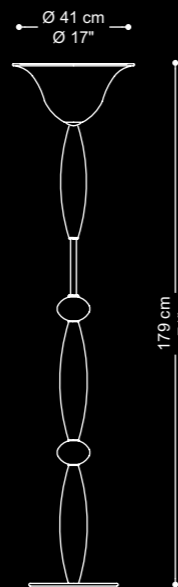

P/ 1 | 1 x MAX 40W E14
 T | 1 x MAX 100W E27

Vetro/Glass

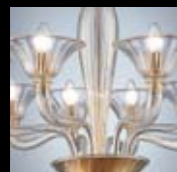

AO

Struttura/Metalwork

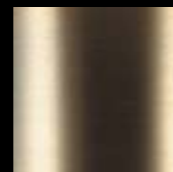

2S



Ouverture S8



Ouverture S



Ouverture P



Ouverture T



Ouverture R



Ouverture A2



GRIFFE

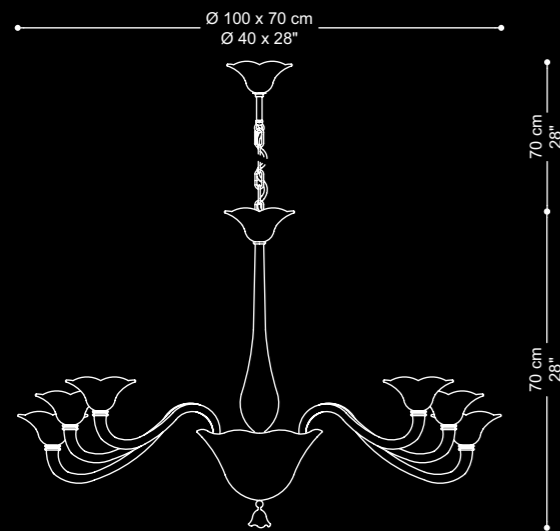

S/ 8 | 8 x MAX 40W E14 | CE

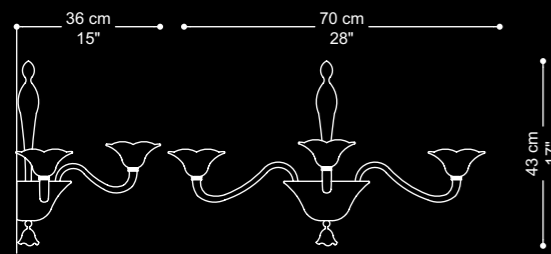

A/ 3 | 3 x MAX 40W E14 | CE

Vetro/Glass



AV

FF

VV

Struttura/Metalwork

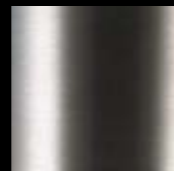

3S



Griffe S8



Griffe A3

STALATTITE

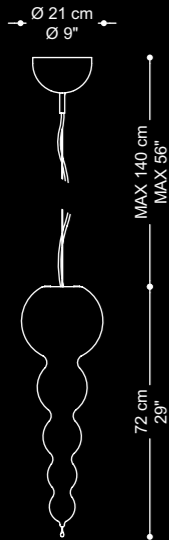

S | 1 x MAX 100W E27 | CE



Stalattite S

Vetro/Glass



AA AO

Struttura/Metalwork

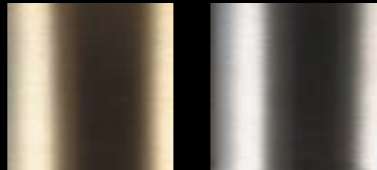

2S 3S

CHOPIN

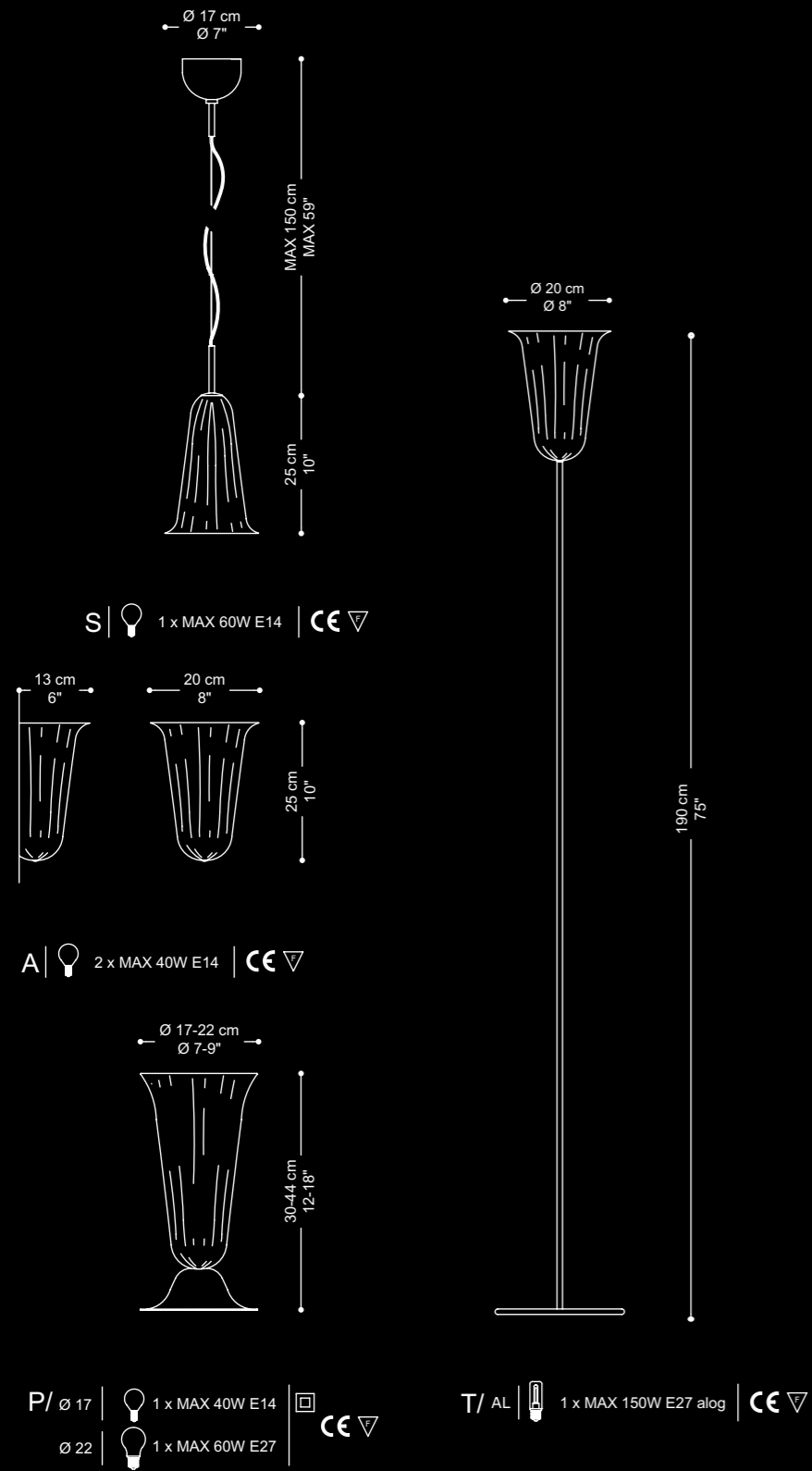

Vetro/Glass



AO XO RO AA

Struttura/Metalwork



2S 3S



Chopin S



Chopin A



Chopin P



Chopin T

MOZART

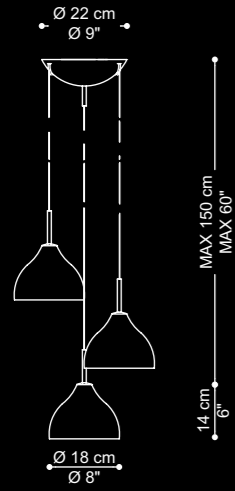

S/ 3 | 3 x MAX 60W E14 | CE ▽

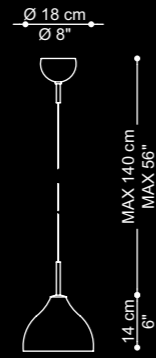

S | 1 x MAX 60W E14 | CE ▽

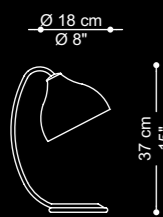

P/ A | 1 x MAX 40W E14 | CE ▽ □

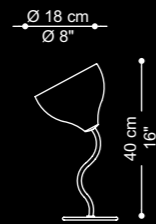

P/ B | 1 x MAX 40W E14 | CE ▽ □

Vetro/Glass



AO

XO

RO

AA

Struttura/Metalwork



2S

3S



Mozart S3



Mozart PA



Mozart PB

BISSET



S | 1 x MAX 100W E27 | CE

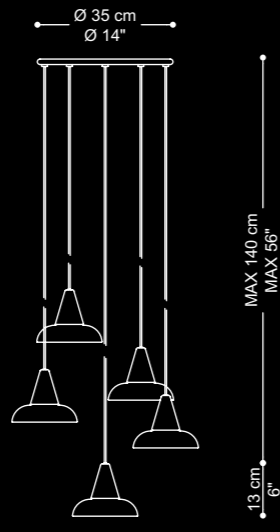

S/3 | 3 x MAX 100W E27 | CE
S/5 | 5 x MAX 100W E27 | CE

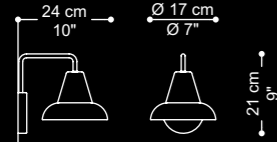

A | 1 x MAX 100W E27 | CE

Vetro/Glass



AA

AO

Struttura/Metalwork



2S

3S



Bisset S3



Bisset A

OTELLO

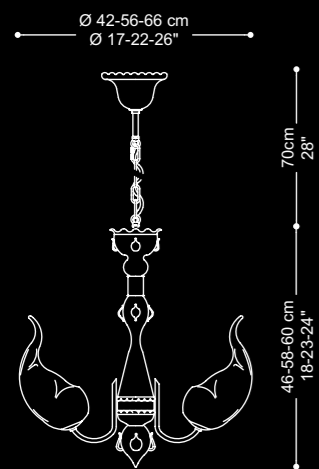

S/ 3-5-6 | n° x MAX 100W E27 | CE

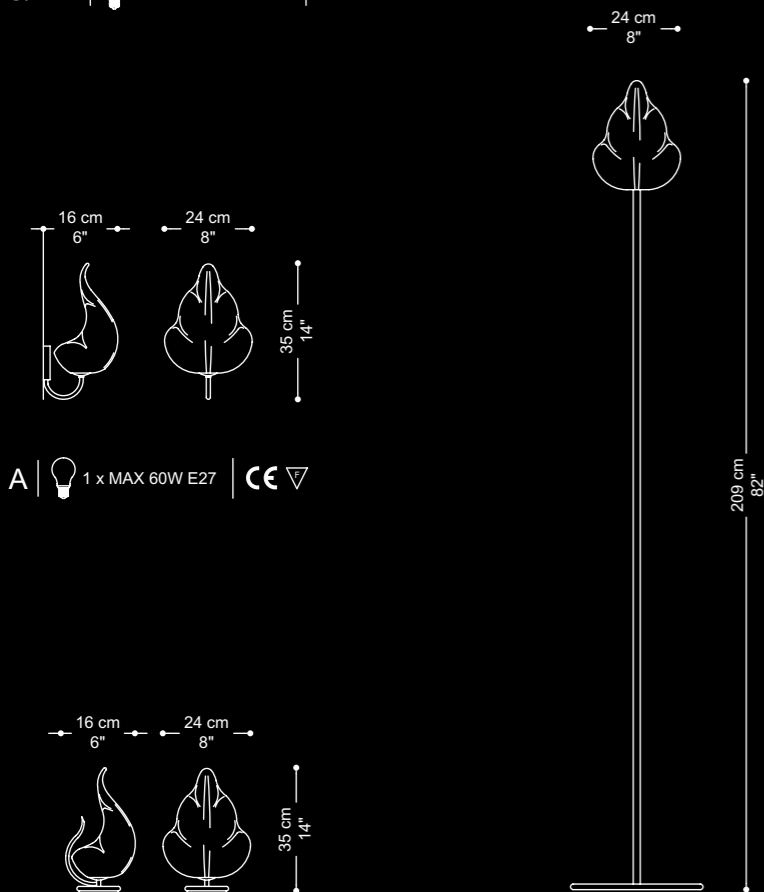

A | 1 x MAX 60W E27 | CE

P | 1 x MAX 40W E27 | CE

T/ AL | 1 x MAX 250W E27 alog | CE

Vetro/Glass



AO

Struttura/Metalwork

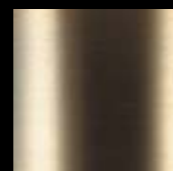

2S



Otello T



Otello S5



Otello P



Otello A

PARSIFAL

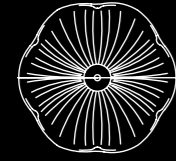
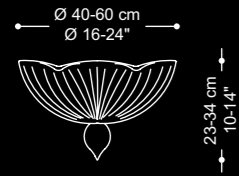

R/ piccola | 3 x MAX 40W E14 | CE
grande | 4 x MAX 60W E14

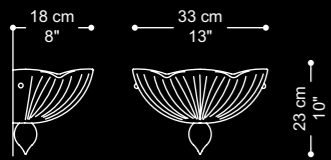

A | 1 x MAX 100W AL R7S | CE

Vetro/Glass



AO

Struttura/Metalwork



2S



Parsifal R



Parsifal A

COROLLA

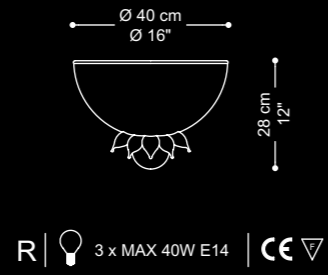
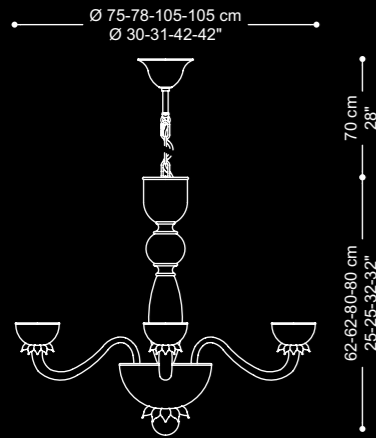

S/ 6-8-10-12 | n° x MAX 40W E14 |

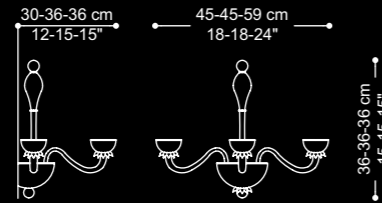

A/ 2-3-5 | n° x MAX 40W E14 |

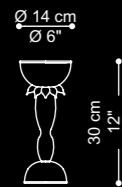

P/ 1 | 1 x MAX 40W E14 |

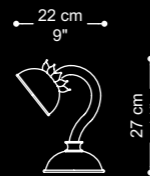

P/ 1L | 1 x MAX 40W E14 |

Vetro/Glass



AB

Struttura/Metalwork



2S

3S



Corolla S10



Corolla R



Corolla S6



Corolla A3



Corolla P1L



Corolla P1

ELOISA

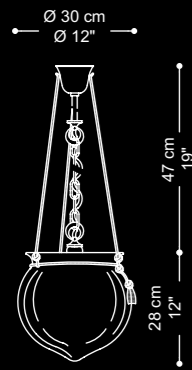

S | 1 x MAX 100W E27 | CE

TRAVIATA

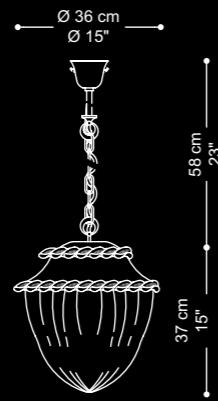

S | 1 x MAX 100W E27 | CE

Vetro/Glass

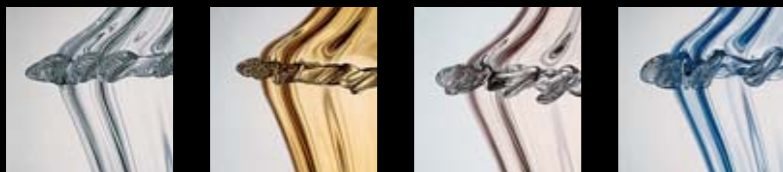

AA

BB

XX

NN

Struttura/Metalwork

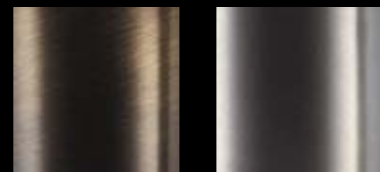

6

9



Eloisa S



Traviata S

SERENATA

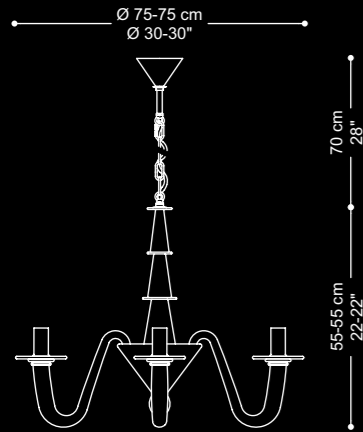

S/ 6-8 | n° x MAX 40W E14 |

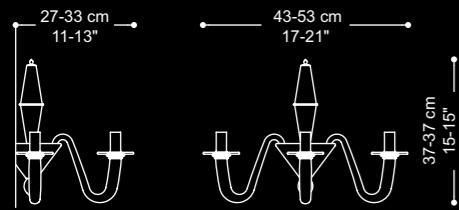

A/ 2-3 | n° x MAX 40W E14 |

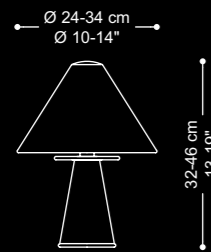

P/ \varnothing 24 | 1 x MAX 40W E14 |
 \varnothing 34 | 1 x MAX 60W E27

Vetro/Glass



AB

Struttura/Metalwork

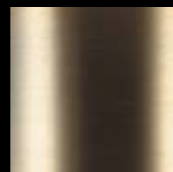

2S



Serenata S8



Serenata A2



Serenata P

ISOTTA

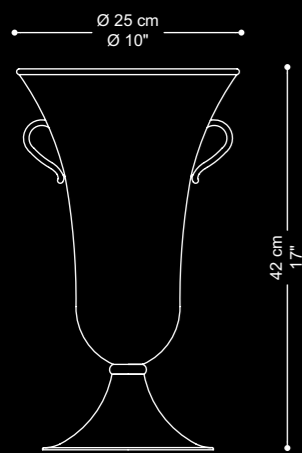

P | 1 x MAX 60W E27 | CE

Vetro/Glass



YO

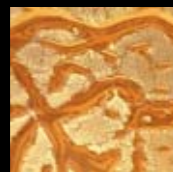

BO

Struttura/Metalwork

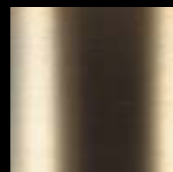

2S



Isotta P

[Torna all'indice](#)
[Back to index](#)

TRISTANO

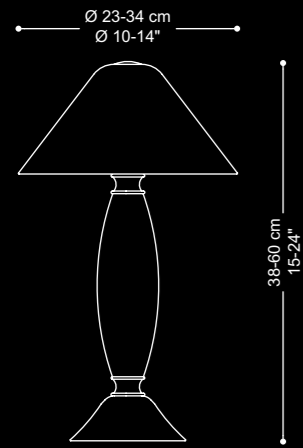

P/ Ø 23 1 x MAX 40W E14
Ø 34 1 x MAX 60W E27

CE

Vetro/Glass



YO



BO

Struttura/Metalwork

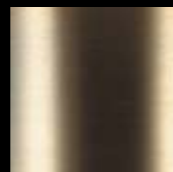

2S



Tristano P

EVASIONE

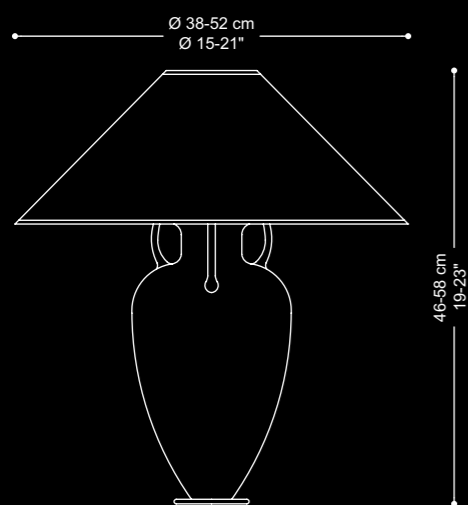

L / Ø 38 | 1 x MAX 100W E27 + 1 x MAX 40W E14 |
L / Ø 52 | 1 x MAX 100W E27 + 1 x MAX 40W E14 |



Vetro/Glass



NN



TT



YO

Struttura/Metalwork

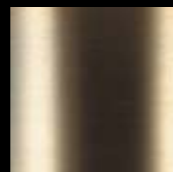

2S



Evasione L

KALIKANTUS

Ø 32 cm
Ø 13"

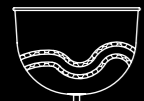

180 cm
71"

Ø 50 cm
Ø 20"

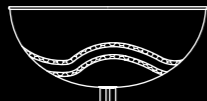

180 cm
71"

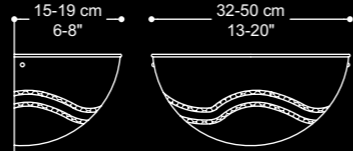

AL 32 | 1 x MAX 100W AL R7S
AL 50 | 1 x MAX 200W AL R7S



T/AL B | 1 x MAX 250W E27 alog | CE

T/AL A | 1 x MAX 250W E27 alog | CE

Vetro/Glass



IC

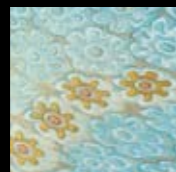

UC

Struttura/Metalwork



2S

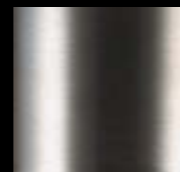

3S



Kalikantus TA



Kalikantus A



Kalikantus TB

FIORDALISO

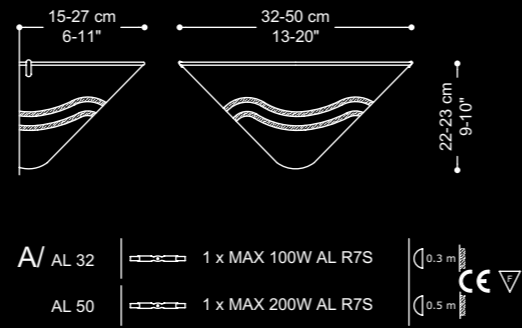
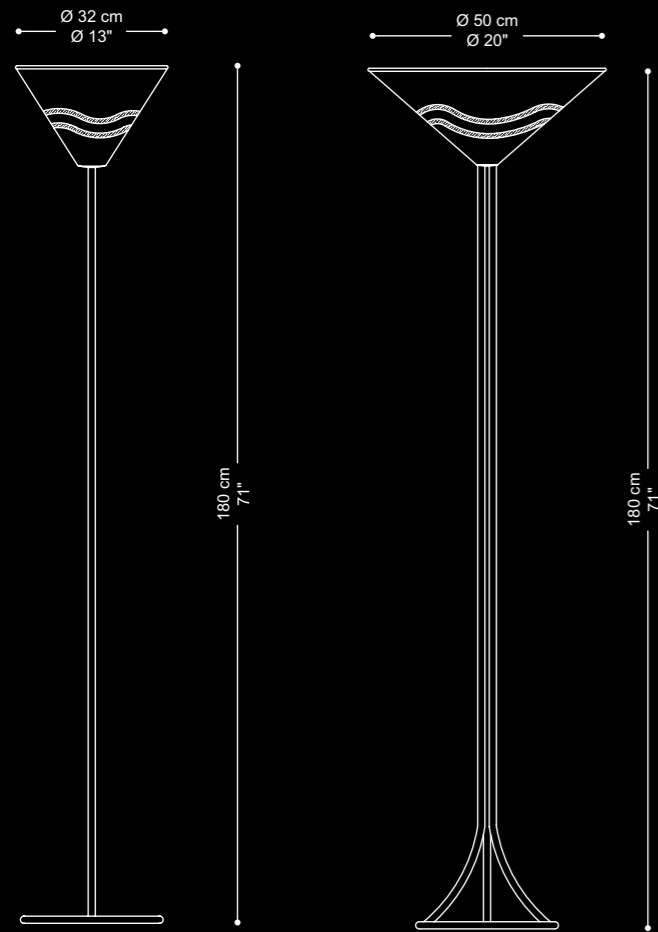

T/ AL B | 1 x MAX 250W E27 alog | CE ∇ | **T/** AL A | 1 x MAX 250W E27 alog | CE ∇

Vetro/Glass

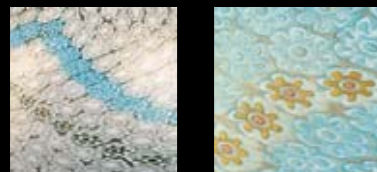

IC

UC

Struttura/Metalwork



2S

3S

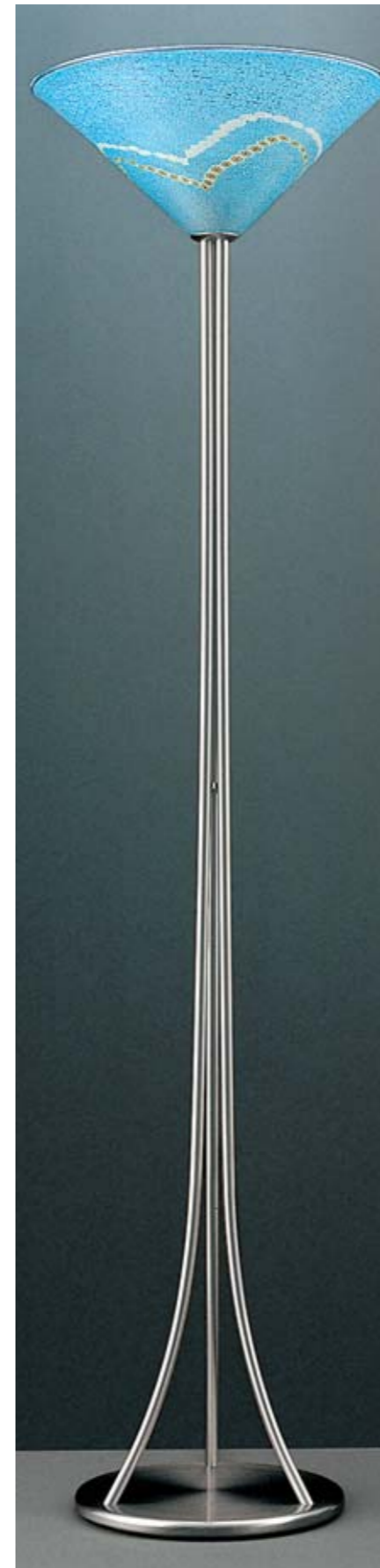

Fiordaliso TB

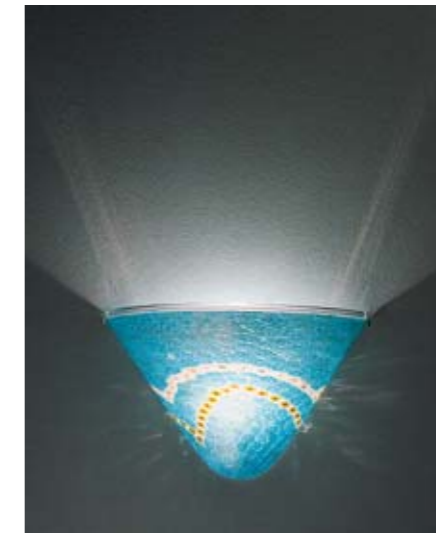

Fiordaliso A



Fiordaliso TA

FIAMMA

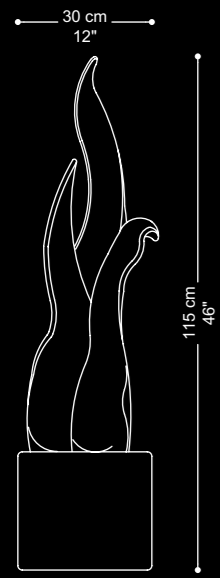

P | 1 x MAX 100W E27 | CE

FAVOLA

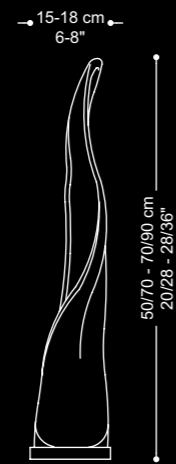

P/A | 1 x MAX 100W E27 | CE
B | 1 x MAX 100W E27

Vetro/Glass



DD

Struttura/Metalwork

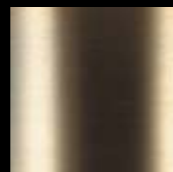

2S



Favola



Fiamma

DUCALE

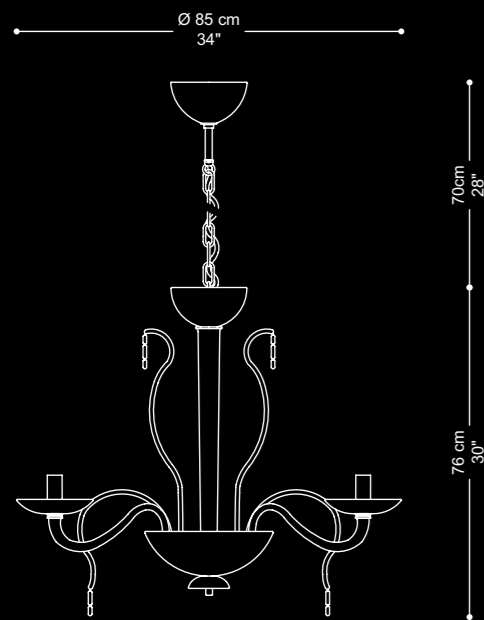

S/ 6 | 6 x MAX 40W E14 | CE

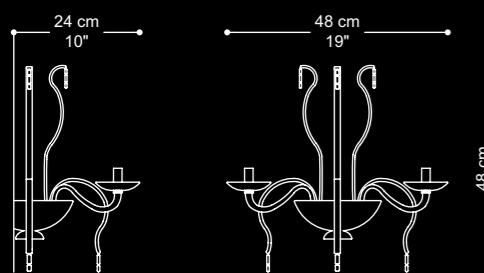

A/ 2 | 2 x MAX 40W E14 | CE

Vetro/Glass



QD

QP

Struttura/Metalwork



3S



Ducale S6

PETALO

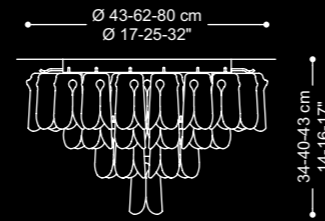
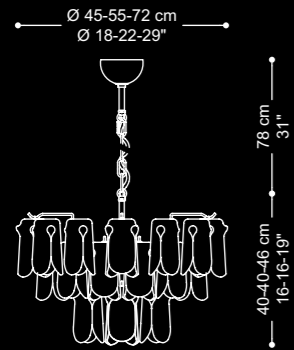

- S/** 45 | 3 x MAX 60W E14 + 1 x MAX 60W E27
 55 | 3 x MAX 60W E14 + 1 x MAX 60W E27
 72 | 7 x MAX 60W E27

- R/** 43 | 3 x MAX 60W E14
 62 | 6 x MAX 60W E27
 80 | 9 x MAX 60W E27

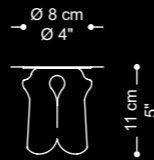

- FARETTO** | 1 x MAX 40W G9
 foro incasso Ø 57 mm.
 spessore MIN. soffitto 10 mm.
 profondità incasso 55 mm.

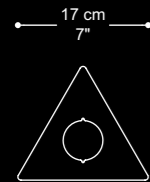

- 102/ FARETTO** | 1 x MAX 35W GU10 - 230V
 foro incasso Ø 72-75 mm.
 spessore soffitto MIN. 10 mm. - MAX 25 mm.
 profondità incasso 100 mm.

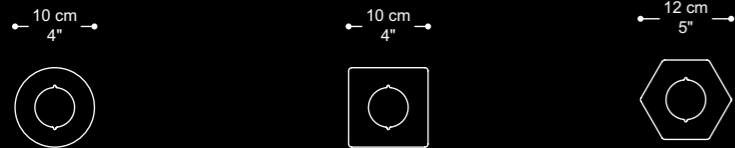

- 101/ FARETTO** | 1 x MAX 35W GU10 - 230V
 foro incasso Ø 72-75 mm.
 spessore soffitto MIN. 10mm. - MAX 25 mm.
 profondità incasso 100 mm.

Vetro/Glass



QB QD

Struttura/Metalwork



2S



Petalo R



Petalo S



Petalo faretto



Petalo faretto



101



Petalo R

TURANDOT

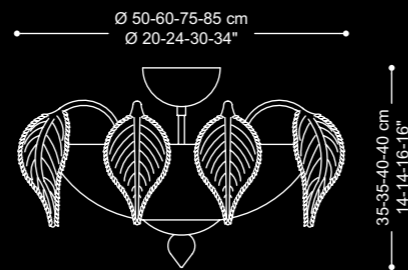
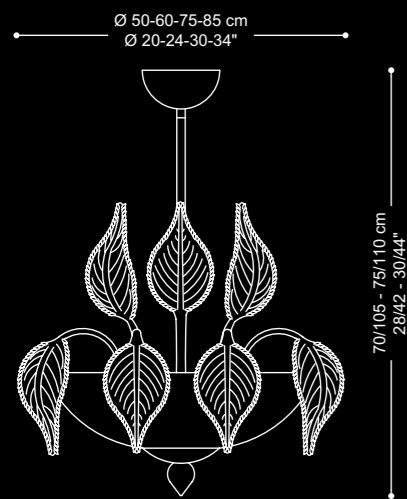

R/ Ø 50	3 x MAX 100W E27
Ø 60	4 x MAX 100W E27
Ø 75	6 x MAX 100W E27
Ø 85	6 x MAX 100W E27



S/ Ø 50	3 x MAX 100W E27
Ø 60	4 x MAX 100W E27
Ø 75	6 x MAX 100W E27
Ø 85	6 x MAX 100W E27

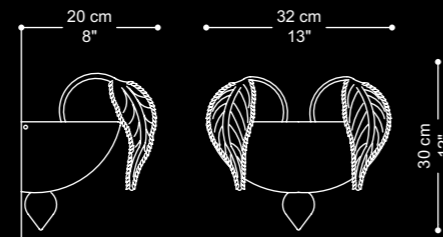
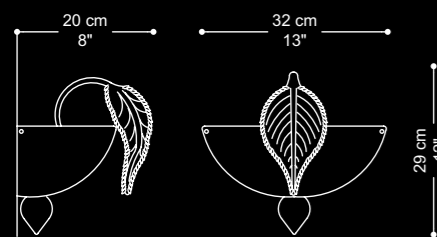

A/ 1 AL | 1 x MAX 100W AL R7S | (0,3 m) CE

A/ 2 AL | 1 x MAX 150W AL R7S | (0,3 m) CE



Vetro/Glass



QB

QD

Struttura/Metalwork



2S

Turandot S



Turandot R



Turandot A



Turandot S

CORDELIA

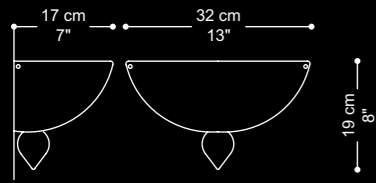

A/ AL | 1 x MAX 100W AL R7S |



Vetro/Glass



QB



QD

Struttura/Metalwork



2S

Cordelia A



[Torna all'indice](#)
[Back to index](#)

CARACALLA

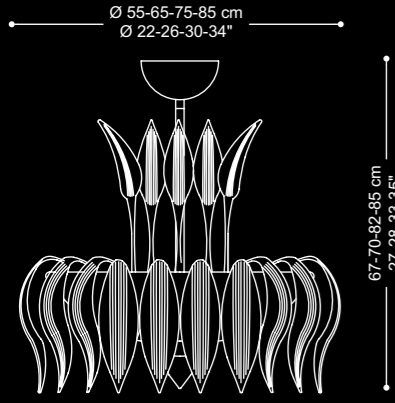

- S/ | 3 x MAX 100W E27
 | 4 x MAX 100W E27
 | 6 x MAX 100W E27
 | 6 x MAX 100W E27

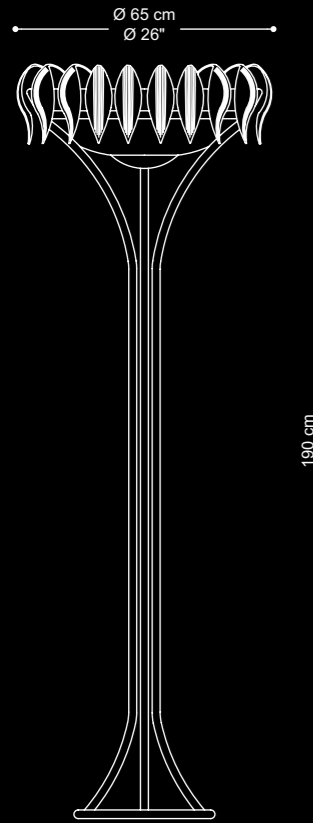

- T | 4 x MAX 100W E27 |

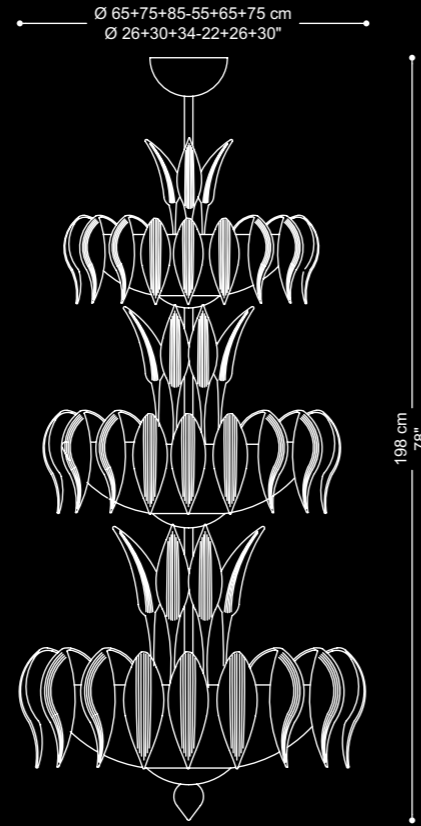

- S/ | 55+65+75 | 13 x MAX 60W E27
 | 65+75+85 | 16 x MAX 60W E27

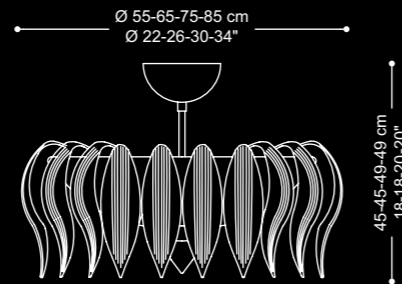

- R/ | 3 x MAX 100W E27
 | 4 x MAX 100W E27
 | 6 x MAX 100W E27
 | 6 x MAX 100W E27



Vetro/Glass



QB

QD

Struttura/Metalwork



2S



Caracalla S3



Caracalla T



Caracalla S



Caracalla R



Caracalla S6

FENICE

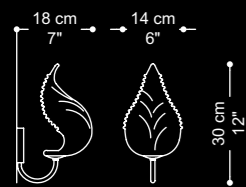

A/ 1 | 1 x MAX 60W E14 | CE

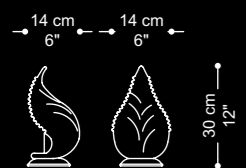

P/ 1 | 1 x MAX 40W E14 | CE

Vetro/Glass



QB



QD



QX

Struttura/Metalwork



2S



Fenice A



Fenice P

DORIS

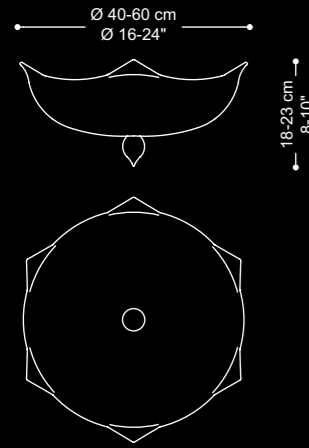

R/ Ø 40 | 3 x MAX 40W E14
 Ø 60 | 4 x MAX 60W E14



GIULIETTA

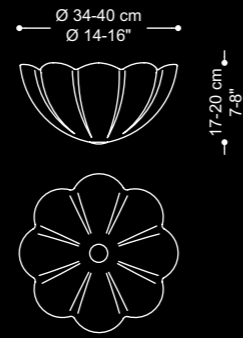

R/ Ø 34 | 3 x MAX 40W E14
 Ø 40 | 3 x MAX 60W E14

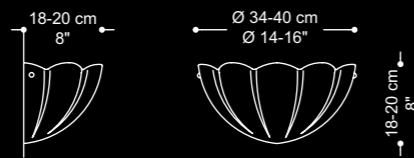

A/ AL 34 | 1 x MAX 100W AL R7S
 AL 40 | 1 x MAX 200W AL R7S



Vetro/Glass



QB

QD

Struttura/Metalwork



2S



Doris R



Giulietta R



Giulietta A

DUSE

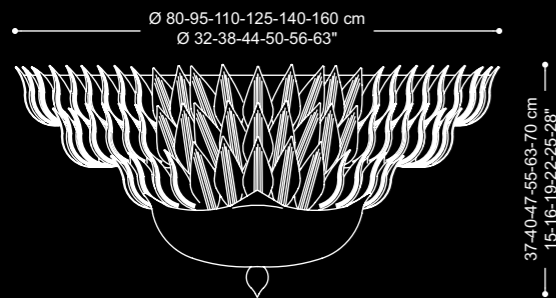

R/ Ø 80		6 x MAX 60W E14
Ø 95		6 x MAX 60W E14 + 3 x MAX 100W E27
Ø 110		12 x MAX 60W E14 + 9 x MAX 100W E27
Ø 125		12 x MAX 60W E14 + 9 x MAX 100W E27
Ø 140		18 x MAX 60W E14 + 9 x MAX 100W E27
Ø 160		21 x MAX 60W E14 + 21 x MAX 60W E27



Vetro/Glass



QB



QD

Struttura/Metalwork



2L



Duse

STONE

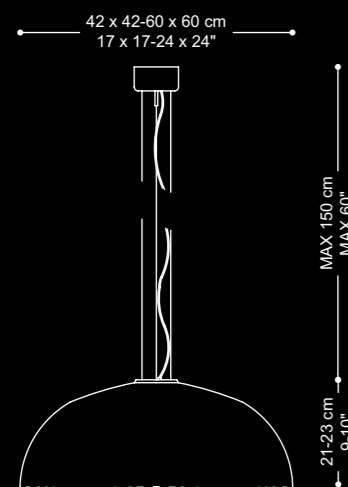

S/ 42 1 x MAX 100W E27 GLOBOLUX Ø 80mm
60 1 x MAX 100W E27 GLOBOLUX Ø 100mm



Vetro/Glass



AA

BB

Struttura/Metalwork

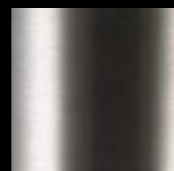

3S



Stone S

631

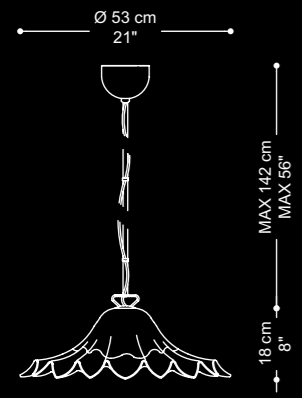

S | 1 x MAX 100W E27 | CE

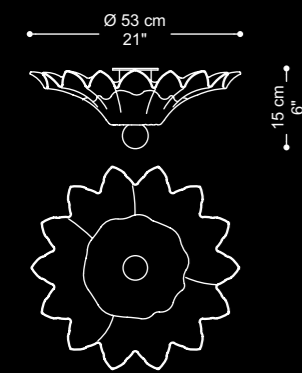

R | 1 x MAX 100W E27 | CE

Vetro/Glass



DB

DD

Struttura/Metalwork

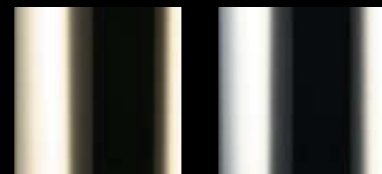

2L

3L

631 S





631 R

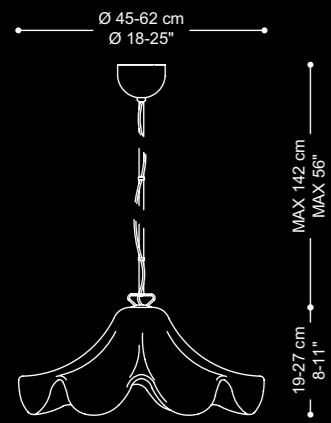

667



S/ $\varnothing 45$ |  1 x MAX 100W E27
 $\varnothing 62$ |  1 x MAX 100W E27

CE 



667



AB

AD

AE

AX

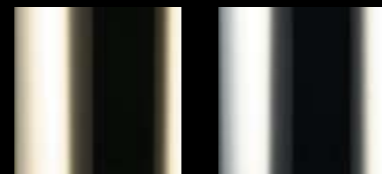

2L

3L

667 S

[Torna all'indice](#)
[Back to index](#)

655

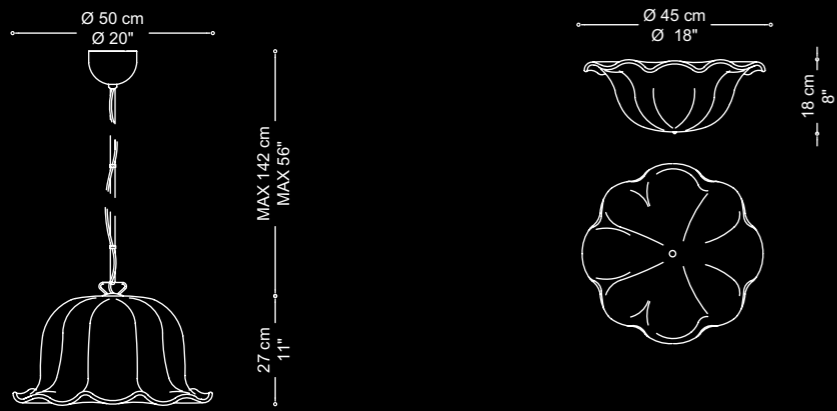

S/Ø 50 | 1 x MAX 100W E27 | CE

R | 3 x MAX 40W E14 | CE

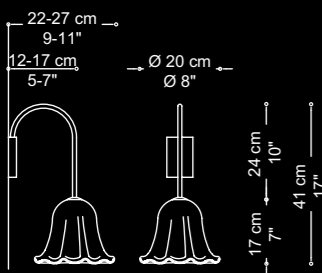

A/ braccio | 1 x MAX 60W E14 | CE

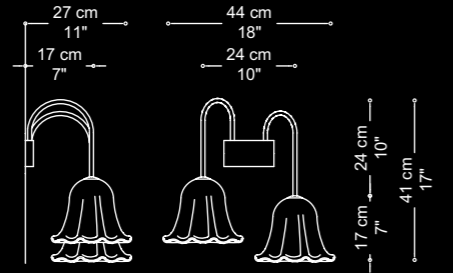

A/ doppio braccio SX | 2 x MAX 60W E14 | CE

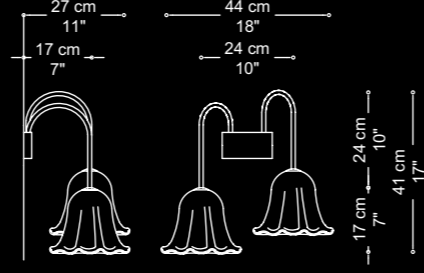

A/ doppio braccio DX | 2 x MAX 60W E14 | CE

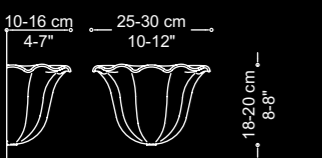

A/ 25 | 1 x MAX 60W E14 | CE
30 | 1 x MAX 100W E27 | CE

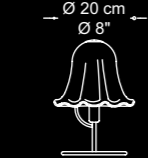

P | 1 x MAX 40W E14 | CE



Vetro/Glass

Struttura/Metalwork



AB AD AE HA HB 2L 3L

655 S

Torna all'indice
Back to index



655 R



655 A



655 P



655 S

900

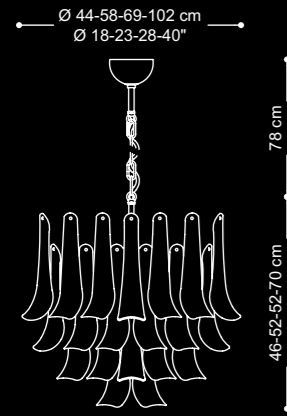

S/	44	4 x MAX 60W E14	CE
	58	5 x MAX 60W E27	
	69	10 x MAX 60W E27	
	102	15 x MAX 60W E27	

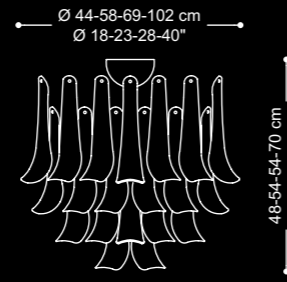

R/	44	4 x MAX 60W E14	CE
	58	5 x MAX 60W E27	
	69	10 x MAX 60W E27	
	102	15 x MAX 60W E27	

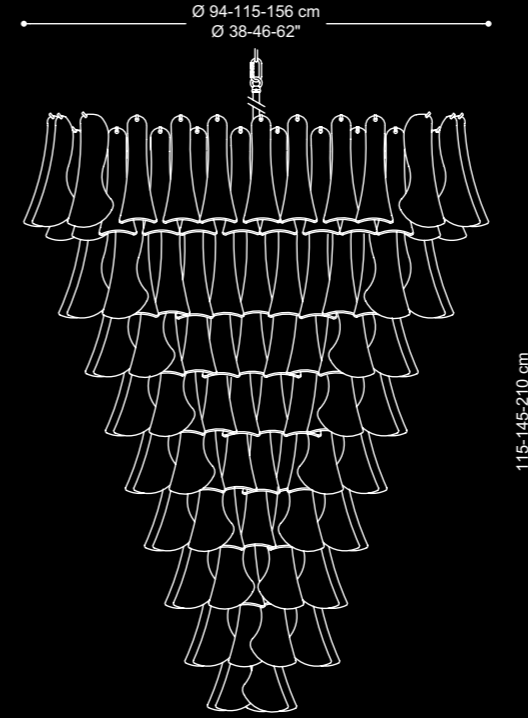

906	R/S	94	12 x MAX 60W E27	CE
		115	16 x MAX 60W E27	
		156	24 x MAX 60W E27	

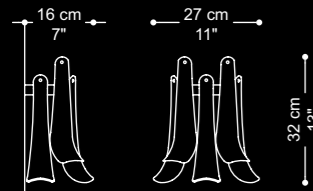

A/	27	2 x MAX 60W E14	CE
----	----	-----------------	----

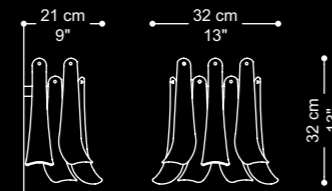

A/	32	2 x MAX 60W E27	CE
----	----	-----------------	----

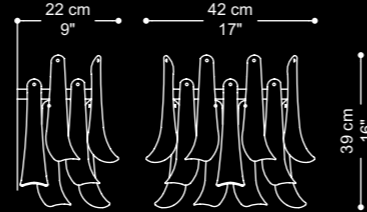

A/	42	2 x MAX 60W E27	CE
----	----	-----------------	----

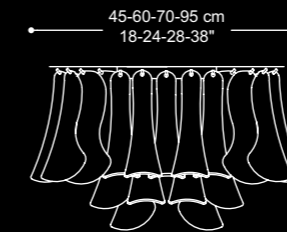

902	R/	45	4 x MAX 60W E27	CE
		60	8 x MAX 60W E27	
		70	8 x MAX 60W E27	
		95	16 x MAX 60W E27	

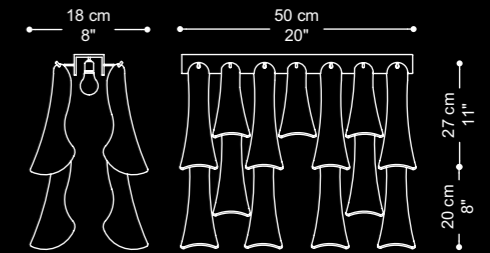

910	lineare	4 x MAX 60W E27	CE
	terminale	4 x MAX 60W E27	
	angolare	8 x MAX 60W E27	

Vetro/Glass



AB AD AX RR

Struttura/Metalwork

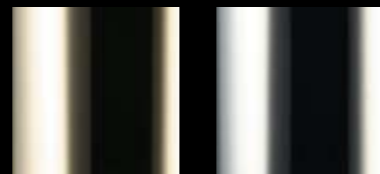

2L 3L



901 S



902 R



901 R



901 A

851

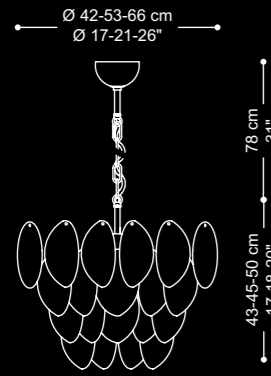

- S/ 42 | 3 x MAX 60W E14 | CE ▽
 53 | 5 x MAX 60W E27
 66 | 9 x MAX 60W E27

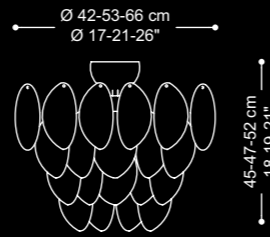

- R/ 42 | 3 x MAX 60W E14 | CE ▽
 53 | 5 x MAX 60W E27
 66 | 9 x MAX 60W E27

852

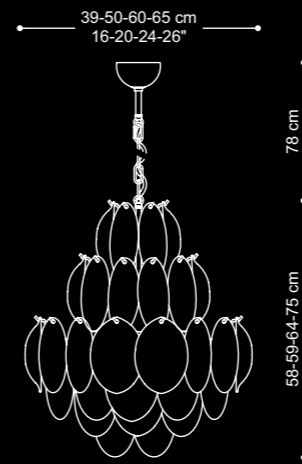

- S/ 39 | 3 x MAX 60W E14 + 4 x MAX 60W E27 | CE ▽
 50 | 8 x MAX 60W E14 + 1 x MAX 60W E27
 60 | 6 x MAX 60W E14 + 6 x MAX 60W E27
 65 | 6 x MAX 60W E14 + 10 x MAX 60W E27

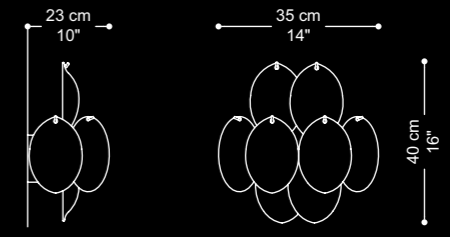

- A/ 35 | 3 x MAX 60W E27 | CE ▽

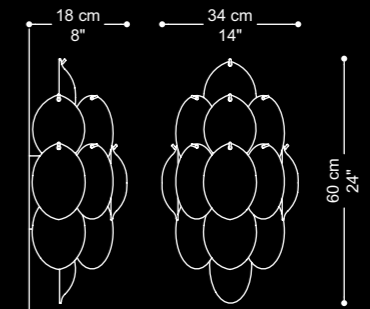

- A/ 34 | 3 x MAX 60W E27 | CE ▽

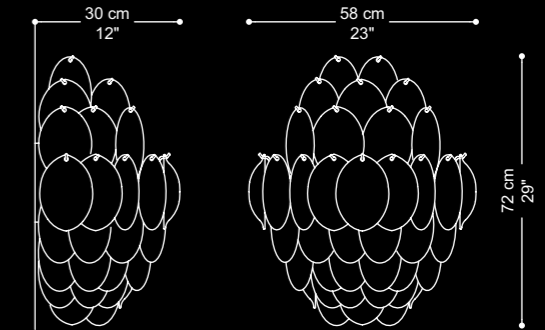

- A/ 58 | 10 x MAX 60W E27 | CE ▽

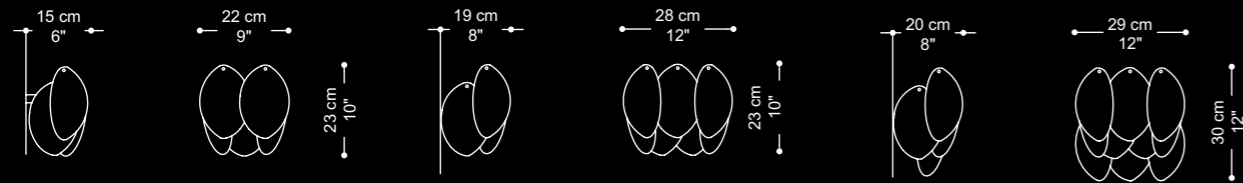

- A/ 22 | 2 x MAX 60W E14 | CE ▽

- A/ 28 | 2 x MAX 60W E27 | CE ▽

- A/ 29 | 2 x MAX 60W E27 | CE ▽

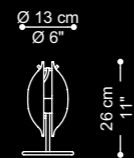

- P | 1 x MAX 40W E14 | CE ▽ □

Vetro/Glass



AB

AD

Struttura/Metalwork



2L

3L



852 S



852 A



851 S



851 R



851 A



851 P

PIERROT

Ø 36-50-61-94 cm
Ø 15-20-24-38"

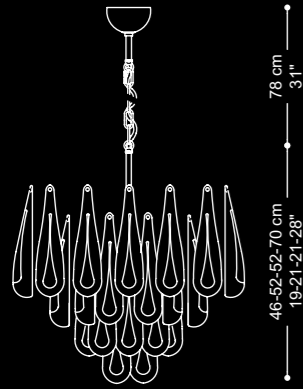

Ø 36-50-61-94 cm
Ø 15-20-24-38"

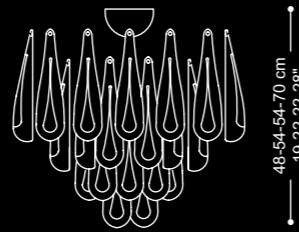

S/ 36	4 x MAX 60W E14	CE ▽
50	5 x MAX 60W E27	
61	10 x MAX 60W E27	
94	15 x MAX 60W E27	

R/ 36	4 x MAX 60W E14	CE ▽
50	5 x MAX 60W E27	
61	10 x MAX 60W E27	
94	15 x MAX 60W E27	

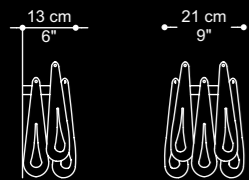

A/ 21 | 2 x MAX 60W E14 | CE ▽

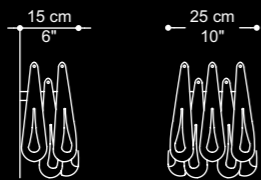

A/ 25 | 2 x MAX 60W E27 | CE ▽

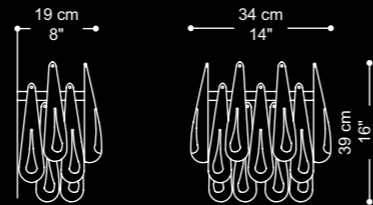

A/ 34 | 2 x MAX 60W E27 | CE ▽



Vetro/Glass



EE

Struttura/Metalwork



2L

3L

Pierrot S



Pierrot R



Pierrot A



Pierrot S

950

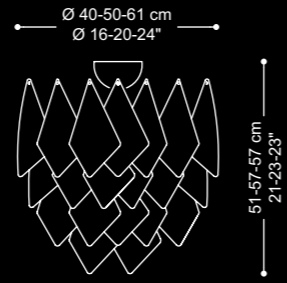
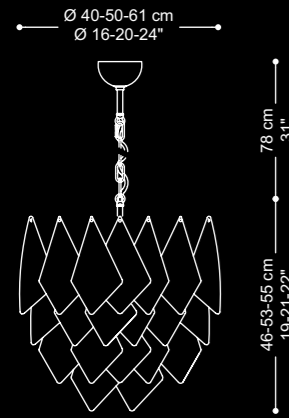

R/ 40	4 x MAX 60W E14	CE
50	5 x MAX 60W E27	
61	10 x MAX 60W E27	

S/ 40	4 x MAX 60W E14	CE
50	5 x MAX 60W E27	
61	10 x MAX 60W E27	

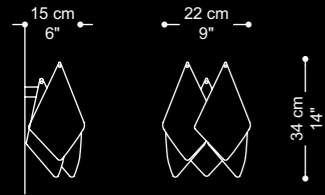

A/ 22 | 2 x MAX 60W E14 | CE

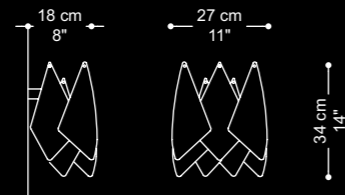

A/ 27 | 2 x MAX 60W E27 | CE

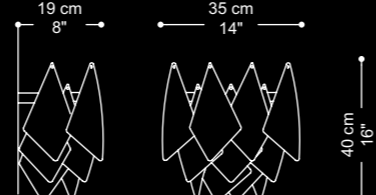

A/ 35 | 2 x MAX 60W E27 | CE



Vetro/Glass



HA

HB

Struttura/Metalwork

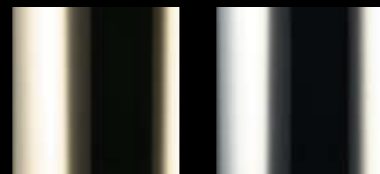

2L

3L

950 S



950 R



950 A



950 S

800

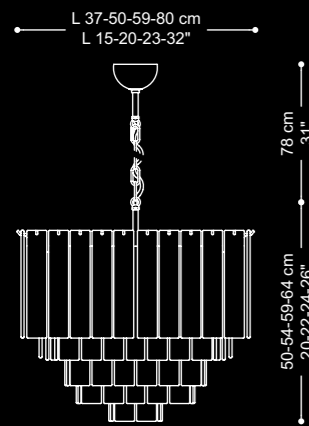

78 cm
31"
50-54-59-64 cm
20-22-24-26"

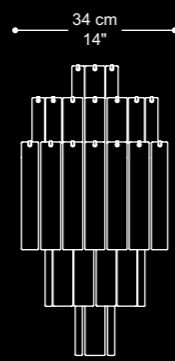

73 cm
30"

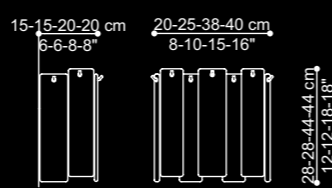

28-28-44-44 cm
12-12-18-18"

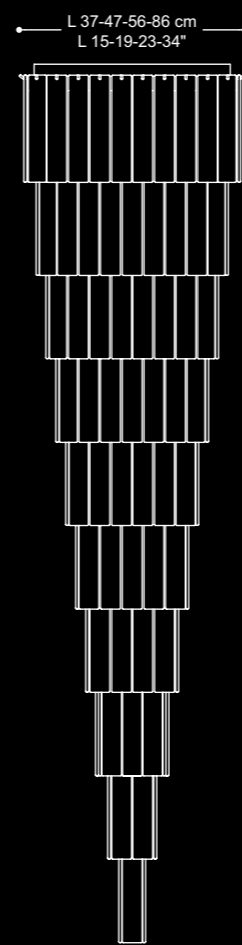

135-177-220-240 cm
54-70-87-95"

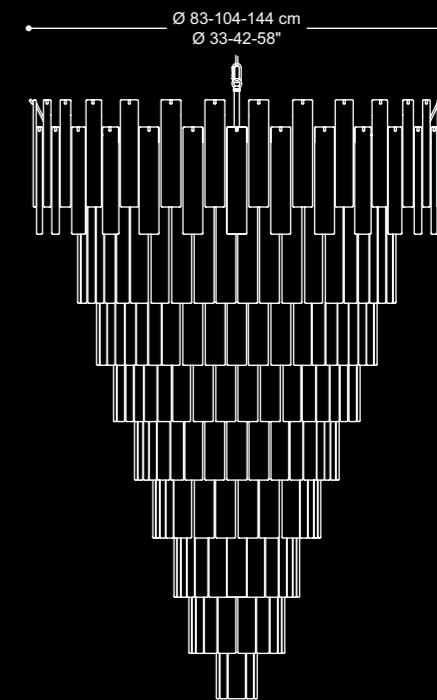

112-145-208 cm
45-58-82"

801

- | | | |
|-------|------------------|----|
| S/ 37 | 5 x MAX 60W E27 | CE |
| 50 | 5 x MAX 60W E27 | |
| 59 | 9 x MAX 60W E27 | |
| 80 | 16 x MAX 60W E27 | |

- | | | |
|-------|-----------------------------------|----|
| A/ 34 | 2 x MAX 60W E14 + 2 x MAX 60W E27 | CE |
|-------|-----------------------------------|----|

- | | | |
|-------|-----------------|----|
| A/ 20 | 2 x MAX 60W E27 | CE |
| 25 | 2 x MAX 60W E27 | |
| 38 | 2 x MAX 60W E27 | |
| 40 | 2 x MAX 60W E27 | |

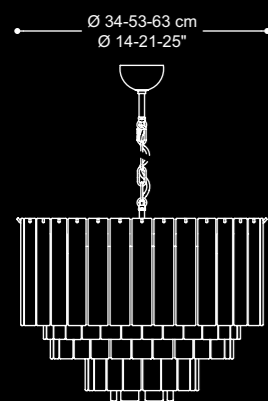

78 cm
31"
50-54-54 cm
20-22-22"

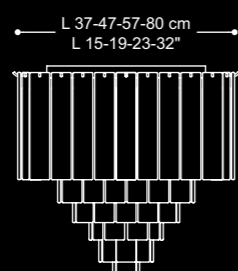

46-46-52-53 cm
19-19-21-21"

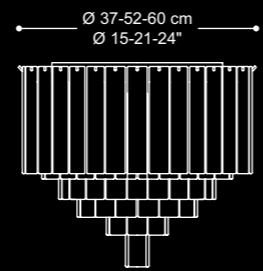

40-52-52 cm
16-21-21"

802

- | | | |
|-------|-----------------------------------|----|
| S/ 34 | 4 x MAX 60W E14 + 1 x MAX 60W E27 | CE |
| 53 | 6 x MAX 60W E27 | |
| 63 | 7 x MAX 60W E27 | |

803

- | | | |
|-------|------------------|----|
| R/ 37 | 4 x MAX 60W E27 | CE |
| 47 | 8 x MAX 60W E27 | |
| 57 | 8 x MAX 60W E27 | |
| 80 | 16 x MAX 60W E27 | |

804

- | | | |
|-------|-----------------|----|
| R/ 37 | 5 x MAX 60W E27 | CE |
| 52 | 5 x MAX 60W E27 | |
| 60 | 8 x MAX 60W E27 | |

805

- | | | |
|-------|------------------|----|
| R/ 37 | 8 x MAX 60W E27 | CE |
| 47 | 12 x MAX 60W E27 | |
| 56 | 16 x MAX 60W E27 | |
| 86 | 24 x MAX 60W E27 | |

806

- | | | |
|--------|------------------|----|
| R/S 83 | 12 x MAX 60W E27 | CE |
| 104 | 16 x MAX 60W E27 | |
| 144 | 24 x MAX 60W E27 | |

810

- | | | |
|-----------|-----------------|----|
| lineare | 4 x MAX 60W E27 | CE |
| terminale | 4 x MAX 60W E27 | |
| angolare | 8 x MAX 60W E27 | |

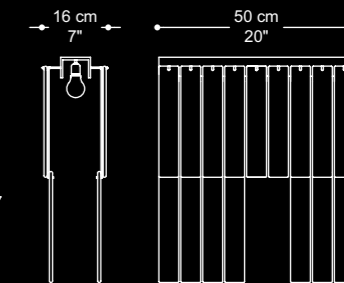

50 cm
20"
28 cm
12"
26.5 cm
11"

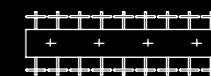

Vetro/Glass

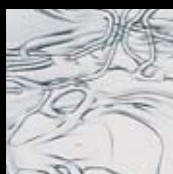

HA



HB

Struttura/Metalwork



2L



3L



803 R



804 R



801 S



802 S



801 A



806 R

807

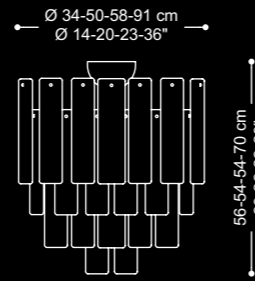
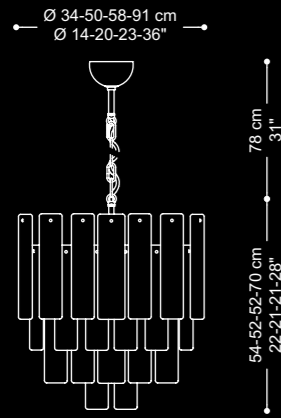

- S/ 34 | 4 x MAX 60W E14
- 50 | 5 x MAX 60W E27
- 58 | 10 x MAX 60W E27
- 91 | 15 x MAX 60W E27

- R/ 34 | 4 x MAX 60W E14
- 50 | 5 x MAX 60W E27
- 58 | 10 x MAX 60W E27
- 91 | 15 x MAX 60W E27

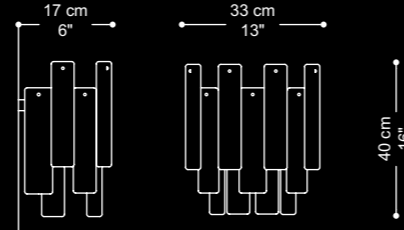
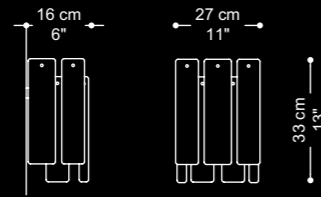
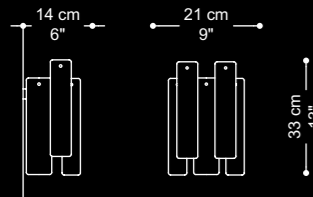

- A/ 21 | 2 x MAX 60W E14

- A/ 27 | 2 x MAX 60W E27

- A/ 33 | 2 x MAX 60W E27

Vetro/Glass



HA



HB

Struttura/Metalwork

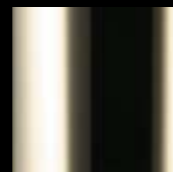

2L



3L



807 S

PRISMA

Ø 38-52-63-96 cm
Ø 15-21-25-38"

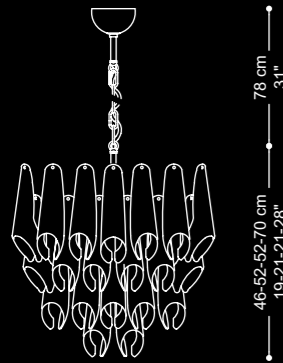

78 cm
31"
46-52-52-70 cm
19-21-21-28"

Ø 38-52-63-96 cm
Ø 15-21-25-38"

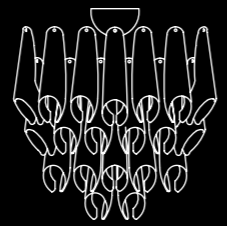

48-54-54-70 cm
19-22-22-28"

S/ 38	4 x MAX 60W E14
52	5 x MAX 60W E27
63	10 x MAX 60W E27
96	15 x MAX 60W E27



R/ 38	4 x MAX 60W E14
52	5 x MAX 60W E27
63	10 x MAX 60W E27
96	15 x MAX 60W E27

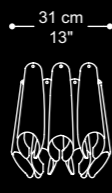
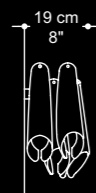

A/ 22 | 2 x MAX 60W E14 | CE

A/ 31 | 2 x MAX 60W E27 | CE

A/ 42 | 2 x MAX 60W E27 | CE

Vetro/Glass



AA



NN



BB



AB



AD

Struttura/Metalwork

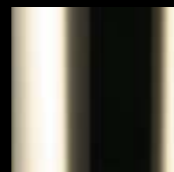

2L



3L



Prisma R



Prisma A



Prisma S

SPECCHI

VENEZIANI

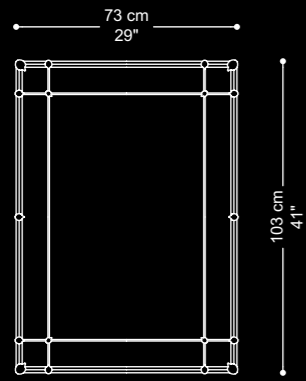

MURANO

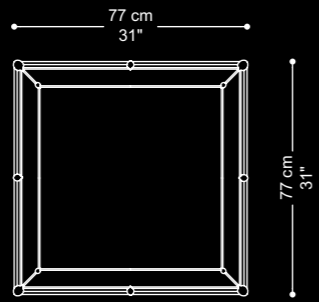

LAGUNA

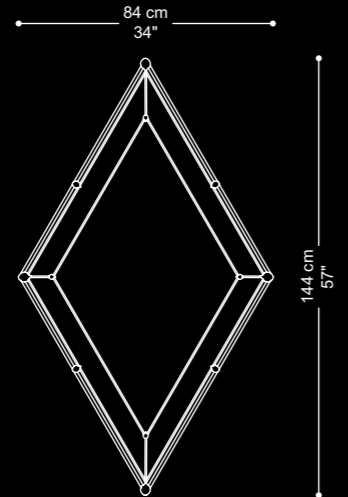
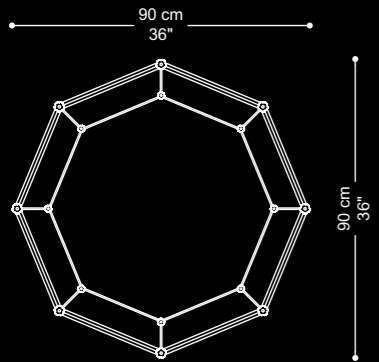
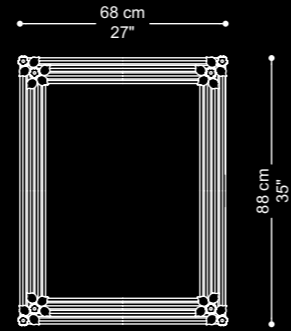
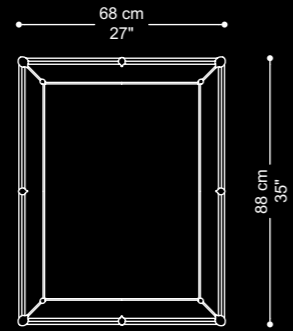
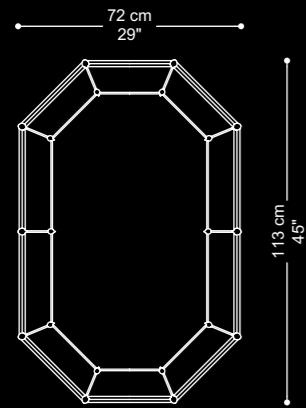
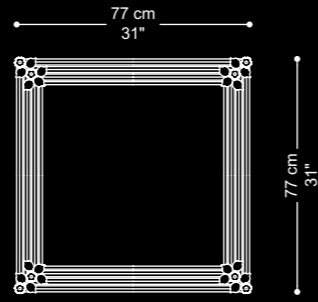

Vetro/Glass



AA AO AX AN BO DD NN OO PP YY



Murano Rombo



Veneziani Ottagono

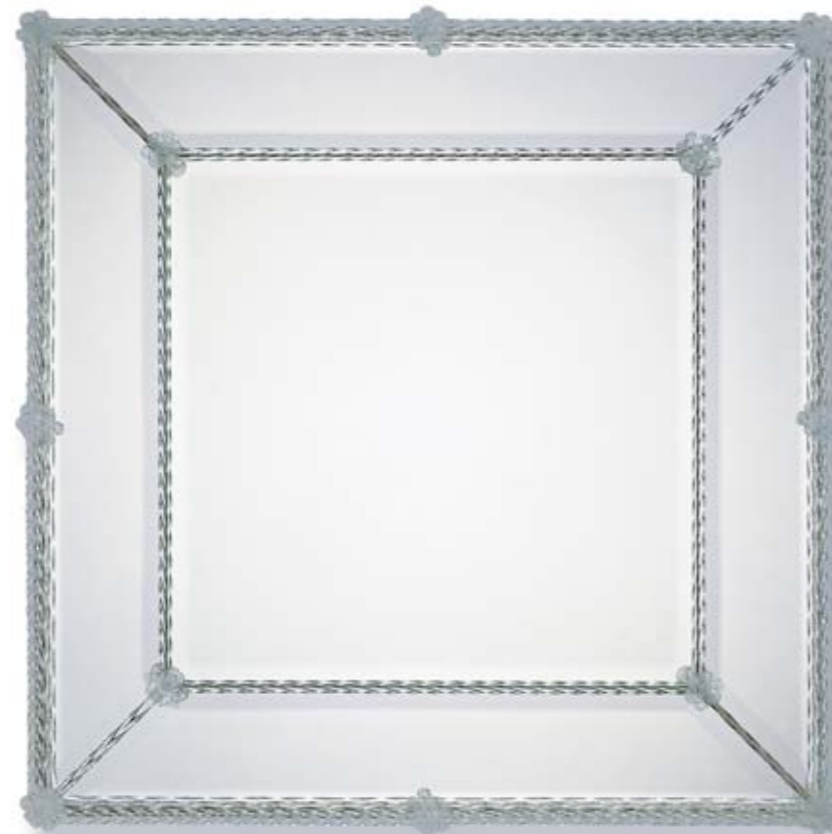

Murano Quadrato



Veneziani Ottagono Rettangolo



Veneziano Rettangolo

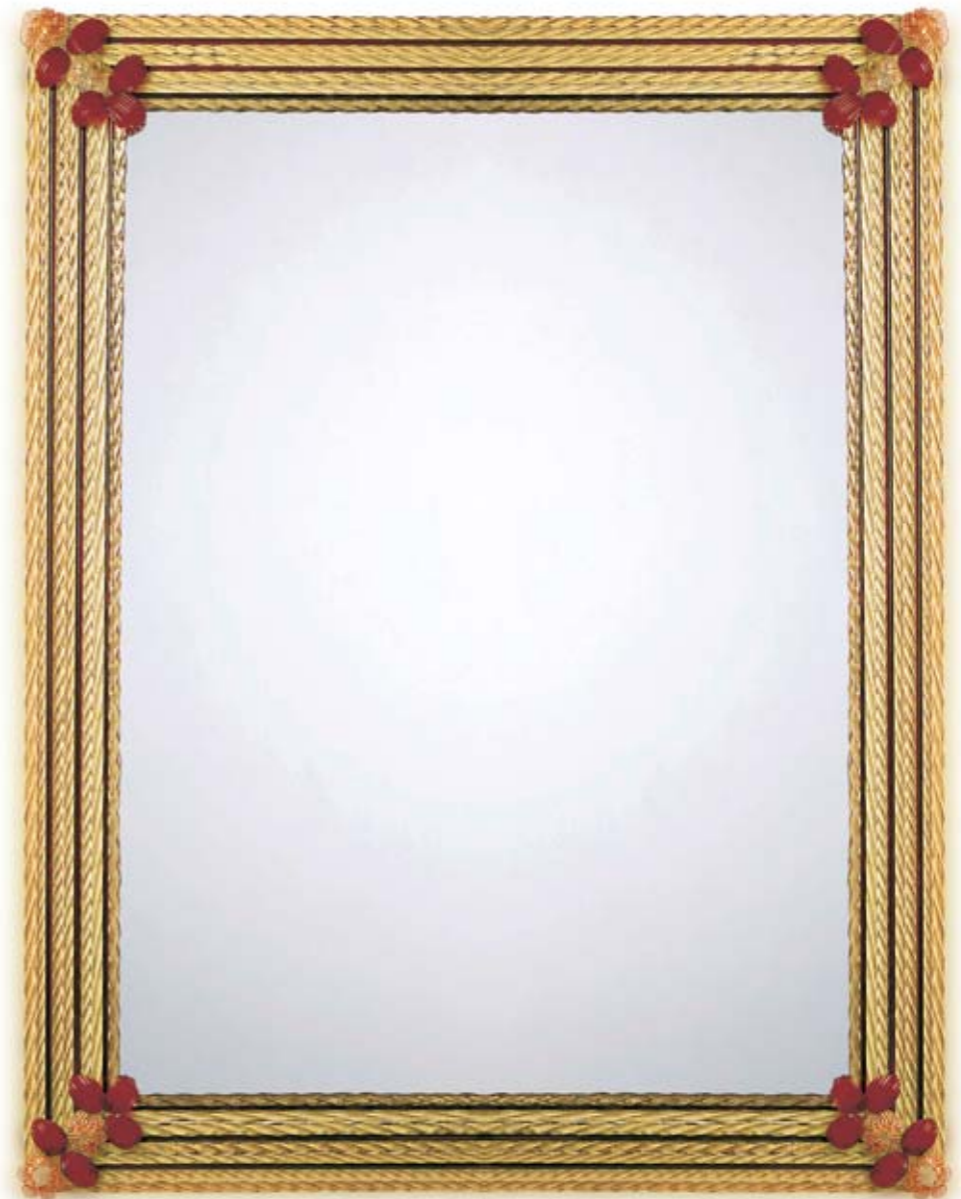

Laguna Rettangolo

VASSOI

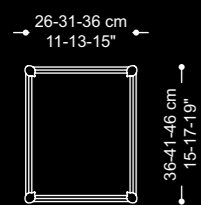

Vassoi

Vetro/Glass

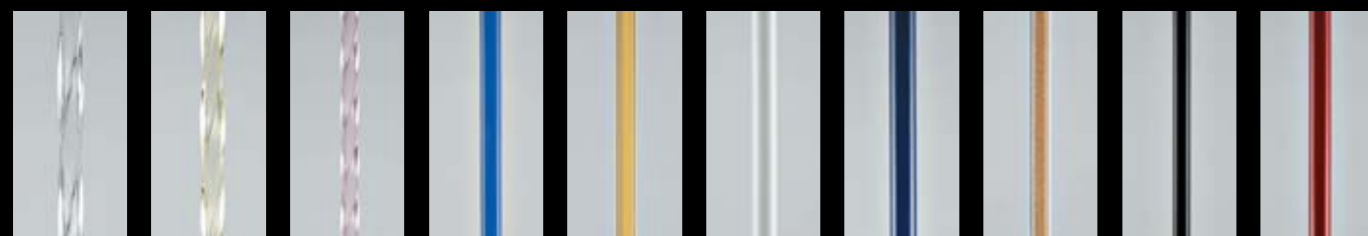

AA AO AX AN BO DD NN OO PP YY

La riproduzione in qualsiasi formato di questo catalogo o di parte di esso è assolutamente proibita senza la previa autorizzazione scritta di **la murrina**® S.p.A.

Il logo **la murrina**® è di esclusiva titolarità e proprietà di **la murrina**® S.p.A.

Non può essere riprodotto né usato per scopi commerciali, senza il consenso scritto di **la murrina**® S.p.A.

L'azienda si riserva di modificare, in qualsiasi momento e senza nessun preavviso, le caratteristiche tecniche dei prodotti illustrati in questo catalogo.

la murrina® declina ogni responsabilità per eventuali errori di stampa presenti nel catalogo.

la murrina® lavora scrupolosamente con i designer e lo staff tecnico e ingegneristico per garantire sempre un elevato standard qualitativo per ogni singolo pezzo della propria produzione.

I materiali scelti e la componentistica elettrica sono di prima qualità. L'assemblaggio e il controllo viene eseguito in maniera rigorosa da manodopera specializzata.

La produzione del vetro soffiato può presentare alcune minime differenze di peso, colore o spessore, dovute alla elaborazione artigianale dei pezzi. Le eventuali bolle e irregolarità presenti nell'impasto non sono difetti ma caratteristiche preziose ed uniche del vetro soffiato e lavorato a mano artigianalmente.

Ogni corpo illuminante è corredato con una busta contenente un foglio di istruzioni e modalità di assemblaggio.

Modifiche e/o riparazioni di qualsiasi natura apportate al prodotto non autorizzate dopo l'acquisto o il mancato rispetto delle istruzioni di montaggio, possono compromettere la sicurezza del prodotto stesso e provocare situazioni di pericolosità per l'utente.

Pertanto **la murrina**® ne declina ogni responsabilità.

Le dimensioni riportate nei disegni tecnici dei prodotti sono espressi in centimetri e pollici.

Gli apparecchi sono forniti con lampadine.



