

UN ALTRO MONDO

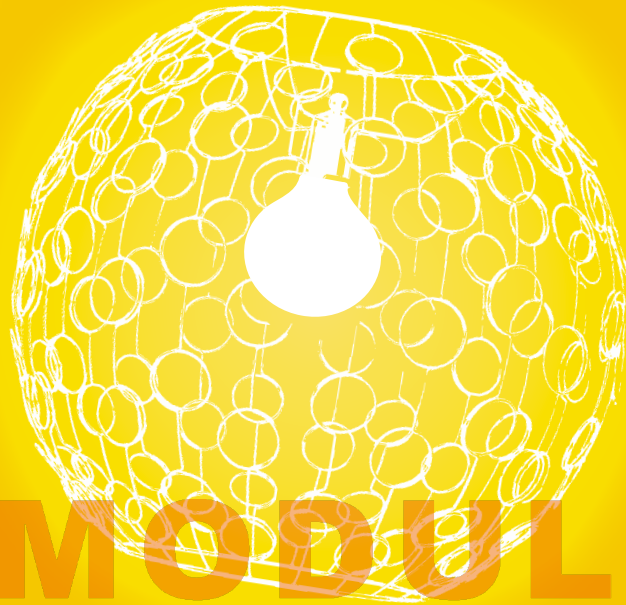

MODUL

ELECTRO

www.modulelectro.ru

LUCERNI®



LUCERNI

UN ALTRO MONDO

IL FASCINO DI UNA SINTESI TRA DUE POLI DEL PENSIERO: RAGIONE ED EMOZIONE. LINEE SOBRIE, ESSENZIALI INTERAGISCONO CON L'AMBIENTE SOTTOLINEANDONE I VALORI FORMALI.

THE CHARM OF A SYNTHESIS BETWEEN TWO POLES OF THOUGHT: REASON AND EMOTION. SIMPLE, ESSENTIAL LINES CONTRIBUTE TO THE ENVIRONMENT BY STRESSING ITS FORMAL VALUES.

LA FASCINACIÓN DE UNA SÍNTESIS ENTRE DOS POLOS DEL PENSAMIENTO: RAZÓN Y EMOCIÓN. LÍNEAS SOBRIAS, ESSENCIALES QUE ENTRAN EN INTERACCIÓN CON EL AMBIENTE SUBRAYANDO SUS VALORES FORMALES.

DER CHARME EINER SYNTHESE ZWISCHEN ZWEI POLEN DES DENKENS: VERNUNFT UND GEFÜHL. SCHLICHTE UND WESENTLICHE LINIEN, DIE MIT DER UMGEBUNG INTERAGIEREN UND DESSEN FORMALE WERTE UNTERSTREICHEN.

LE CHARME D'UNE SYNTHÈSE ENTRE DEUX POLES DE LA PENSÉE: RAISON ET ÉMOTION. DES LIGNES SOBRES, ESSENTIELLES TRAVAILLENT EN SYNTONIE AVEC L'ENVIRONNEMENT EN SOULIGNANT LEUR VALEUR FORMELLE.

ОЧАРОВАНИЕ СИНТЕЗА МЕЖДУ ДВУМЯ ПОЛЮСАМИ МЫСЛИ: РАЗУМ И ЭМОЦИЯ. СТРОГИЕ, СУЩЕСТВЕННЫЕ ЛИНИИ ИЗЛУЧАЮТ ЭЛЕГАНТНОСТЬ, ПОДЧЕРКИВАЯ ФОРМАЛЬНУЮ ЦЕННОСТЬ ПОМЕЩЕНИЯ.

2 Metro

Design Arch. Roberto De Biasi



8 Drop

Design Studio Vrola



14 T-Wing

Design Studio Vrola

24 Bubble

Design LuceLab



32 Informale

Design LuceLab

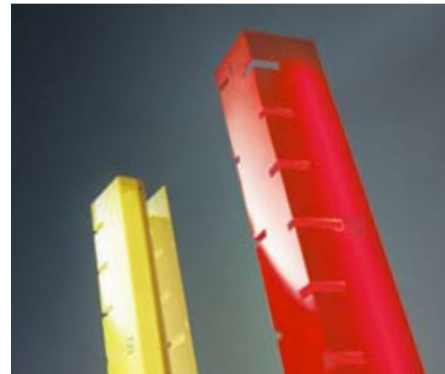

MODULO ELECTRO
www.modulelectro.ru

Metro

Design Arch. Roberto De Biasi

Misura e luce: la geometria lineare per definire un corpo illuminante. Linee rigorose e pulizia di forme colorate uniscono utilità e divertimento per creare un' atmosfera di piacere e gioco.

Measure and light: linear geometry for the definition of a lighting fixture. Rigorous lines and cleanliness of coloured shapes join utility and fun in order to create an atmosphere of pleasure and play.

Medidas y luz: la geometría lineal para definir un cuerpo iluminante. Líneas rigurosas y limpieza de formas coloradas unen la utilidad y la diversión para crear una atmósfera de placer y de juego.

Maß und Licht: Definition einer Leuchte mittels linearer Geometrie. Die strengen Linien und die Reinheit in farbigen Formen verbinden Nützlichkeit und Spaß in einer Atmosphäre von Freude und Spiel.

Mesure et lumière: la géométrie linéaire qui définit un appareil d'éclairage. Les lignes rigoureuses et la propreté des formes colorées combinent l'utilité et l'amusement pour créer une atmosphère de plaisir et de jeu.

Размер и свет: линейная геометрия для определения осветительного прибора. Строгие линии и чистота цветных форм соединяют практичность с забавой, чтобы создать приятную и игривую атмосферу.

MODULO
ELECTRO
www.modulelectro.ru



MODULO
 ELECTRO
www.modulelectro.ru



L126 50 XX A



L126 50 XX C



L126 50 XX B





L126 50 XX A



A
BIANCO
 WHITE
 BLANCO
 WEISS
 BLANC
 БЕЛОЕ

B
GIALLO
 YELLOW
 AMARILLO
 GELB
 JAUNE
 ЖЕЛТЫЙ

C
ROSSO
 RED
 ROJO
 ROT
 ROUGE
 КРАСНОЕ

MODULO
ELECTRO
 L126 50
 struttura / frame XX
 diffusore / shade A - B - C
 2x21W G5 T5
 www.modulelectro.ru

189 cm



25 x 30 cm

Drop

Design Studio Vnola

Giochi della natura: morbide linee ondulate che si ispirano all'affascinante movimento di cerchi perfetti generatesi dalla caduta di una goccia d' acqua.

Games of nature: soft wavy lines that are inspired by the fascinating motion of perfect circles generated by a falling drop of water.

Juegos de la naturaleza: suaves líneas onduladas que se inspiran en el movimiento fascinante de círculos perfectos generados por una gota que cae en el agua.

Spiele der Natur: weiche Wellenlinien, die sich an die faszinierende Bewegung der perfekten Kreise inspirieren, welche ein fallender Wassertropfen erzeugt.

Jeux de la nature: lignes douces et ondulées qui s'inspirent au mouvement fascinant des cercles parfaits générés par une goutte d'eau qui tombe.

Игры природы: Мягкие волнообразные линии, вдохновляющиеся чарующим движением идеальных колец, которые возникли в результате падения капли воды.

The logo for MODUL ELECTRO features the brand name in a bold, orange, sans-serif font. The word 'MODUL' is on the top line, and 'ELECTRO' is on the bottom line. On either side of the text is a square icon containing a smaller square. Below the logo, the website address 'www.modulselectro.ru' is written in a light gray, lowercase font.

www.modulselectro.ru

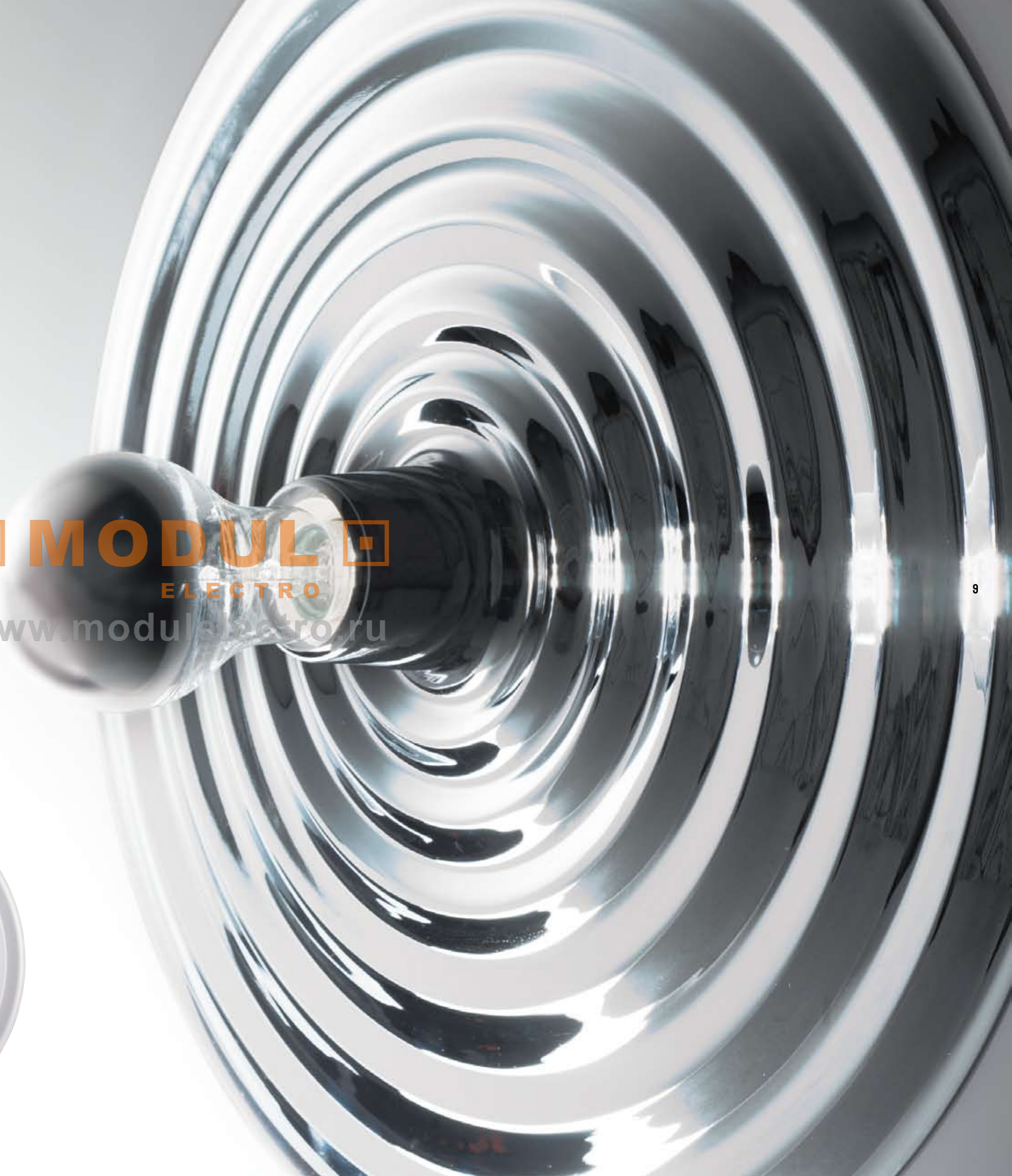

L128 36 G2 A



10



MODUL
ELECTRO

www.modulelectro.ru



11

L128 36 F5 A

L128 36 2A A



12

L128 36 N6 A

L128 36 N4 A



2A
CROMATO LUCIDO
CHROME - PLATED
CROMADO BRILLANTE
VERCHROMTES METALL
CHROME POLI
ХРОМИРОВАННОЙ БЛЕСТЯЩЕЕ

F5
BIANCO
WHITE
BLANCO
WEISS
BLANC
БЕЛОЕ

G2
ARGENTO
SILVER
PLATA
SILBER
ARGENT
ФОЛЬГА



N3
VERDE
GREEN
VERDE
GRÜN
VERT
ЗЕЛЕННЫЙ

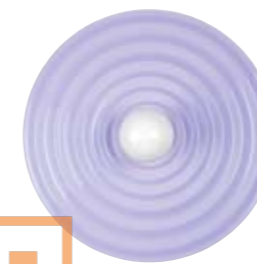

N4
LILLA
VIOLET
VIOLETA
VIOLETT
VIOLET
ЛИЛОВЫЙ

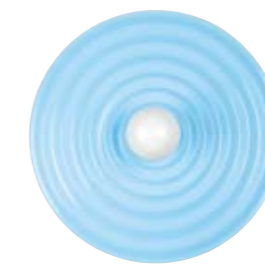

N5
CELESTE
LIGHT BLUE
AZÚL
HELL BLAU
BLEU CIEL
ГОЛУБОЙ



N6
ROSA
ROSE
ROSA
ROSAROT
ROSE
РОЗОВЫЙ



N7
ARANCIONE
ORANGE
ANARANJADO
ORANGE
ORANGE
ОРАНЖЕВЫЙ

MODULO ELECTRO
www.modulelectro.ru

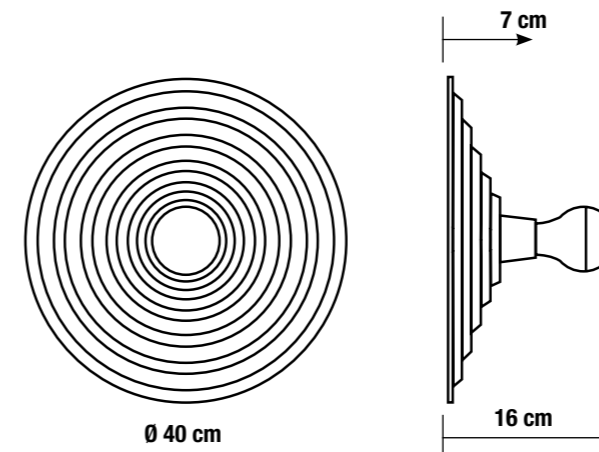

L128 36
struttura / frame 2A-F5-G2-N3-N4-N5-N6-N7
diffusore / shade A

Max 1 x 150W E27 
Classe I   

T-wing

Design Studio Vrold

Ali di luce: la tecnologia si fonde con il design. Forme sinuose e leggere che illuminano nelle diverse intensità e tonalità i nuovi ambienti moderni.

Wings of light: technology melted into design. Sinuous and light shapes that illuminate the new modern environment in different intensities and tonalities.

Alas de luz: la tecnología se funde en el design. Formas sinuosas y ligeras que iluminan en diferentes intensidades y tonos el nuevo ambiente moderno.

Lichtflügel: die Technik verschmilzt im Design. Gewundene leichte Formen beleuchten in unterschiedlicher Intensität und Farbe ihr neues modernes Ambiente.

Ailes de lumière: la technologie se fonde dans le design. Formes sinueuses et légères qui illuminent en différentes intensités et teintes le nouveau environnement moderne.

Крылья света: технология сливается с дизайном. Извилистые легкие формы, освещающие с различной интенсивностью и оттенками новые современные помещения.

The logo for MODUL ELECTRO features the word "MODUL" in a large, bold, orange sans-serif font, with "ELECTRO" in a smaller, orange sans-serif font below it. On either side of "MODUL" is a square icon containing a smaller square.

www.modulelectro.ru



L127 22 3A A

www.modulelectro.ru



L127 34 3A A

L127 35 3A A

MODUL
ELECTRO
www.modulelectro.ru



L127 37 3A A



L127 51 3A A

L127 45 3A A

MODULO
ELECTRO
www.modulelectro.ru





3A
ACCIAIO SPAZZOLATO
 BRUSHED STEEL
 ACERO CEPILLADO
 STAHL GEBÜRSTET
 ACIER BROSSÉ
 ПОЛИРОВАННОЙ СТАЛИ

A
METACRILATO TRASPARENTE MONO-SATINATO
 MONO -SATINED TRANSPARENT METHACRYLATE
 METACRILATO TRASPARENTE MONO - SATINADO
 TRANSPARENTES MONO-SATINIERTES METHACRYLAT
 MÉTHACRYLATE TRANSPARENT MONO-SATIN
 ПРОЗРАЧНЫЙ МЕТАКРИЛАТ, МАТИРОВАННЫЙ С ОДНОЙ СТОРОНЫ

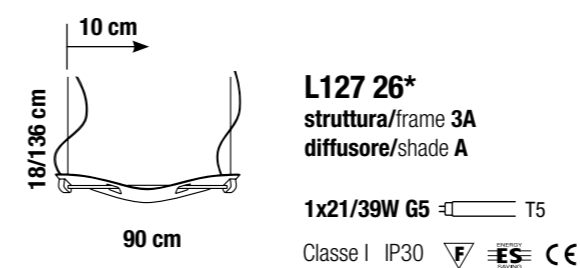
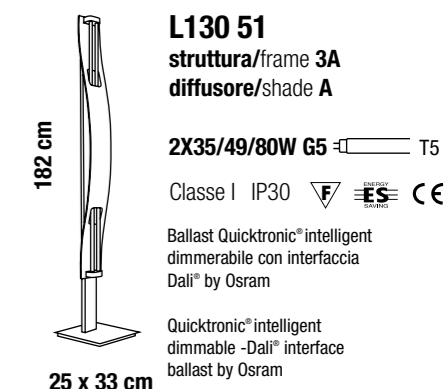
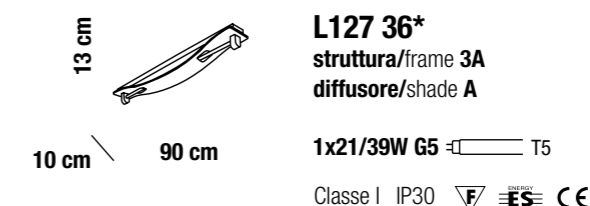
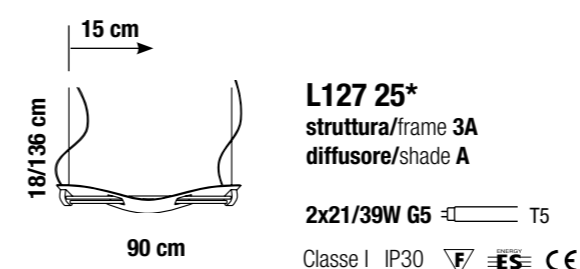
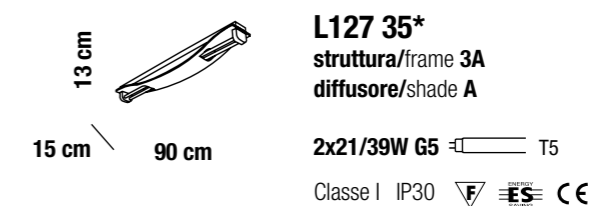
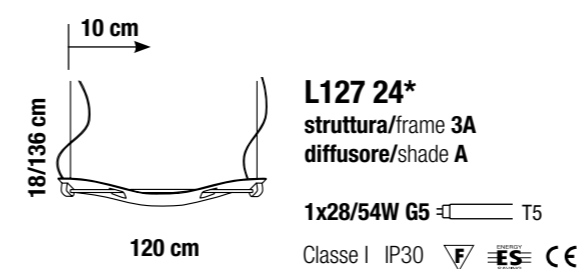
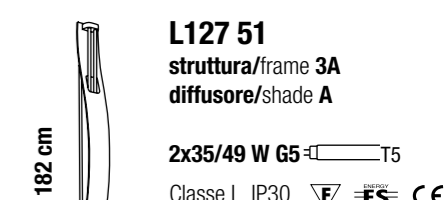
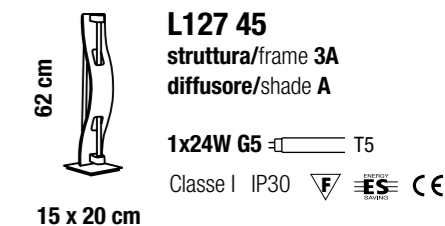
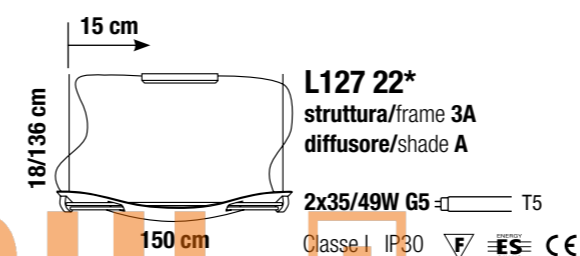

*Su richiesta ballast dimmerabile
 On request dimmable ballast



L127 45 3A A

MODULO
ELECTRO
www.modulelectro.com

Bubble

Design Luce Lab

**Leggerezza e fantasia: tante bolle sospese nell'aria.
Una sola fonte luminosa al centro che si intravede tra le stilizzazioni
dei cerchi in cromo, nero o bianco.**

Lightness and imagination: lots of bubbles suspended in the air.
A single light source at the centre that can be made out between the stylization
of the circles in chrome, black or white.

Ligereza y fantasía: muchas burbujas suspendidas en el aire. Una sola fuente
de luz en el centro que se puede vislumbrar entre la estilización de los círculos
en cromo, negro o blanco.

Leichtigkeit und Phantasie: viele in der Luft schwebenden Blasen. Eine einzige
Lichtquelle in der Mitte, die zwischen den stilisierten Kreisen in Chrom,
Schwarz oder Weiß zu erkennen ist.

Légèreté et fantaisie: beaucoup de bulles en suspension dans l'air.
Une seule source de lumière au centre, qui peut être aperçue entre les stylisation
des cercles en chrome, noir ou blanc.

Легкость и фантазия: множество подвешенных в воздухе пузырьков.
Единственный источник света в центре, едва заметный за стилизацией
черных и белых хромо́вых колец.



MODULO
ELECTRO
www.modulelectro.ru





L129 23 2A A

MODUL
ELECTRO
www.modulelectro.com



L129 22 I3 A





L129 51 I3 A



L129 32 I3 A

MODULO
ELECTRO
www.modulelectro.com



L129 45 F5 A

L129 47 F5 A



L129 24 F5 A

F5
BIANCO
 WHITE
 BLANCO
 WEISS
 BLANC
 БЕЛОЕ

I3
NERO
 BLACK
 NEGRO
 SCHWARZ
 NOIR
 ЧЕРНЫЙ

2A
CROMATO LUCIDO
 CHROME – PLATED
 CROMADO BRILLANTE
 VERCHROMTES METALL
 CHROME POLI
 ХРОМИРОВАННОЙ БЛЕСТЯЩЕЕ



MODULO ELETTRO
www.modulelectro.ru

L129 22
 struttura / frame 2A-F5-I3
 diffusore / shade A
 MAX 1x150W E27
 Classe I

L129 32
 struttura / frame 2A-F5-I3
 diffusore / shade A
 MAX 1x100W E27
 Classe I

L129 51
 struttura / frame 2A-F5-I3
 diffusore / shade A
 MAX 1x250W E27

L129 23
 struttura / frame 2A-F5-I3
 diffusore / shade A
 MAX 1x150W E27
 Classe I

L129 45
 struttura / frame 2A-F5-I3
 diffusore / shade A
 MAX 1x150W E27

L129 24
 struttura / frame 2A-F5-I3
 diffusore / shade A
 MAX 1x150W E27
 Classe I

L129 47
 struttura / frame 2A-F5-I3
 diffusore / shade A
 MAX 1x150W E27

Informale

Design Luce Lab

Allegria di colori e giochi di luce: il gesto delicato di una mano ispirata ha saputo fondere purezza di linee e forza di contenuto estetico in una semplice...informalità.

Joy of colours and light effects: the delicate gesture of an inspired hand has managed to melt the purity of lines and strength of an aesthetic content into a simple ... informality.

Alegría de colores y juegos de luz: el delicado gesto de una mano inspirada ha sabido conjugar la pureza de las líneas y la fuerza de contenido estético en una simple ...informalidad.

Lustigkeit der Farben und der Lichtspiele: die zarte Geste einer inspirierten Hand schmilzt die Reinheit der Linien und die Stärke des ästhetischen Inhalts zu einer einfachen ... Informalität.

Gaieté de couleurs et jeux de lumière: le geste délicat d'une main inspirée a su fondre la pureté des lignes et la force du contenu esthétique dans une simple ...informalité.

Радость цветов и переливаний света: легкое движение вдохновленной руки смогло смешать чистоту линий с силой эстетического содержания, создав простую... неформальность.

MODUL
ELECTRO

www.modulelectro.ru



L 784 06 2A A

MODULO ELECTRO
www.modulelectro.ru



L 784 05 2A F



L 784 24 2A E

MODUL
ELECTRO
www.modulelectro.ru



L 784 23 2A B



L 784 36 2A A

L 784 36 2A B

L 784 36 2A C

38

MODULO
ELECTRO
www.modulelectro.ru

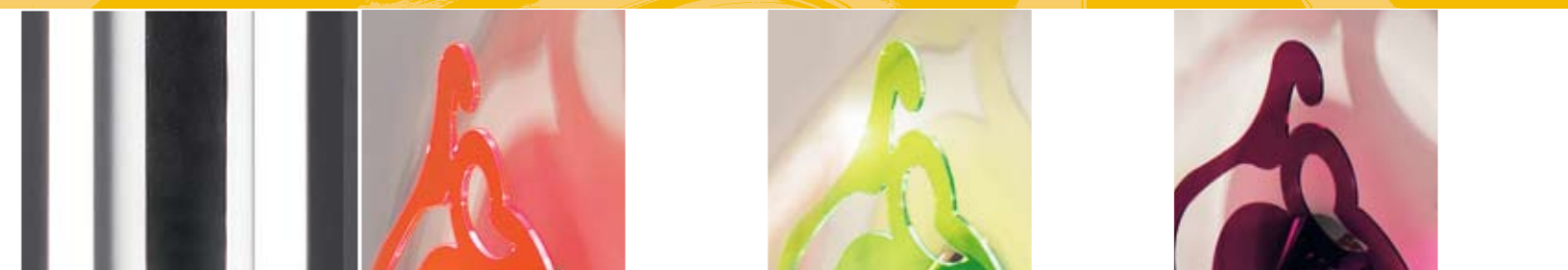

2A
CROMATO LUCIDO
CHROME - PLATED
CROMADO BRILLANTE
VERCHROMTES METALL
CHROME POLI
ХРОМИРОВАННОЙ БЛЕСТЯЩЕЕ

A
METACRILATO ARANCIO FLUO
FLUORESCENT ORANGE METHACRYLATE
ANARANJADO FLUORESCENTE METACRILATO
FLUORESZIERENDE ORANGE METHACRYLAT
ORANGE FLUORESCENT MÉTHACRYLATE
ФЛУОРЕСЦЕНТНЫЙ ОРАНЖЕВЫЙ
МЕТАКРИЛАТ

B
METACRILATO GIALLO FLUO
FLUORESCENT YELLOW METHACRYLATE
AMARILLO FLUORESCENTE METACRILATO
FLUORESZIERENDE GELB METHACRYLAT
JAUNE FLUORESCENT MÉTHACRYLATE
ФЛУОРЕСЦЕНТНЫЙ ЖЕЛТЫЙ МЕТАКРИЛАТ

C
METACRILATO FUCSIA SCURO
DARK FUCHSIA METHACRYLATE
FUCHSIA OSCURO METACRILATO
DUNKEL FUCHSIA METHACRYLAT
MÉTHACRYLATE FUCHSIA FONCÉ
ФУКСИЯ МЕТАКРИЛАТ



D
METACRILATO TRASPARENTE
TRANSPARENT METHACRYLATE
TRANSPARENTE METACRILATO
TRANSPARENT METHACRYLAT
TRANSPARENT MÉTHACRYLATE
ПРОЗРАЧНЫЙ МЕТАКРИЛАТ



E
METACRILATO TRASPARENTE CON MOTIVO "WHITE MAGIC"
TRANSPARENT METHACRYLATE WITH "WHITE MAGIC" MOTIF
TRANSPARENTE METACRILATO CON MOTIVO "WHITE MAGIC"
TRANSPARENT METHACRYLAT MIT "WHITE MAGIC" MOTIV
TRANSPARENT MÉTHACRYLATE AVEC MOTIF "WHITE MAGIC"
ПРОЗРАЧНЫЙ МЕТАКРИЛАТ С УЗОРОМ "WHITE MAGIC"



F
COMBINAZIONE MISTA
MIXED COMBINATION
COMBINACIÓN MIXTA
MISCHKOMBINATION
COMBINAIXON MIXTE
СМЕШАННАЯ КОМБИНАЦИЯ

39

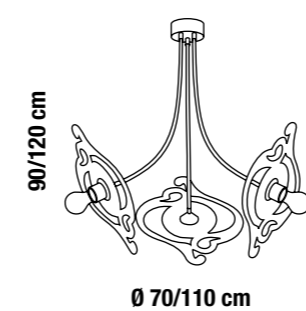

L 784 05
struttura / frame 2A
diffusore/shade A-B-C-D-E-F
Max 3x150W E27
Classe I

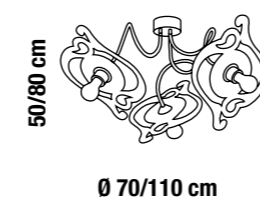

L 784 06
struttura / frame 2A
diffusore/shade A-B-C-D-E-F
Max 3x150W E27
Classe I

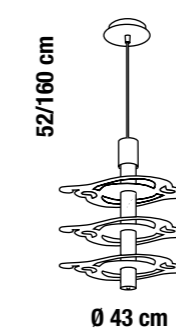

L 784 23
struttura / frame 2A
diffusore/shade A-B-C-D-E-F
1x36W 2G11
Classe I

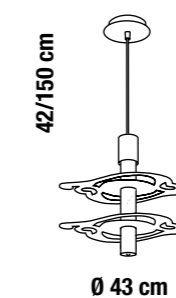

L 784 24
struttura / frame 2A
diffusore/shade A-B-C-D-E-F
1x24W 2G11
Classe I

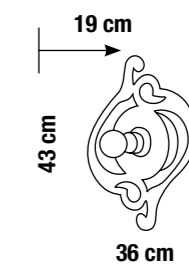

L 784 36
struttura / frame 2A
diffusore/shade A-B-C-D-E-F
Max 1x150W E27
Classe I

MODUL

ELECTRO

www.modulelectro.ru

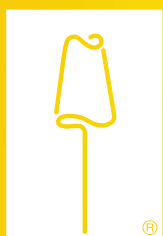

LUCERNI

LUCERNI è un marchio GruppoLAMPE
LUCERNI is a GruppoLAMPE trademark

LAMPE srl - Via Fratelli Agrizzi, 13
32031 Fener di Alano di Piave (BL) Italy
Italia T 0439 778777
Export T +39 0439 779544
F +39 0439 779562

www.lucerni.com

italia@lucerni.com

export@lucerni.com

TUTTI I PRODOTTI LUCERNI SONO MODELLI DEPOSITATI
ALL LUCERNI PRODUCTS ARE REGISTERED MODELS
LOS PRODUCTOS LUCERNI SON MODELOS REGISTRADOS
ALLE LUCERNI PRODUKTE SIND EINGETRAGENE MODELLE
LES PRODUITS LUCERNI SONT DES MODÈLES DÉPOSÉS
ВСЕ МОДЕЛИ ИЗДЕЛИЙ LUCERNI ЗАРЕГИСТРИРОВАНЫ

Prodotto e distribuito da LAMPE S.R.L.
Azienda certificata ISO 9001:2000



Reg. Nr. 9101.LMPE

L'azienda si riserva, ferme restando le caratteristiche basilari del prodotto, di apportare tutte quelle modifiche che riterrà necessarie allo scopo di migliorare la qualità del prodotto stesso.

While maintaining the basic characteristics of the product, the company reserves the right to make modifications at any time with the sole aim of quality improvement.

La empresa tiene derecho sin modificar las características básicas del producto, a modificar lo que estimara necesario para mejorar la calidad del producto mismo.

Die Firma behält sich das Recht vor, jederzeit Änderungen vorzunehmen, die die Qualität ihres Produktes verbessern können; allerdings unter Beibehaltung der Grundeigenschaften.

La société se réserve la possibilité, sans changer les caractéristiques du produit, d'apporter toutes les modifications qu'elle jugera nécessaires pour améliorer la qualité du produit.

Фирма оставляет за собой право, сохраняя базовые характеристики изделия, вносить любые изменения, которые она считает необходимыми для повышения качества изделия.

Il perfetto funzionamento di tutti gli articoli Lucerni è garantito con una tensione di rete compresa tra i 220v e i 230v ad una frequenza di 50/60Hz.

The perfect working of Lucerni articles is guaranteed only for a tension included between 220v and 230v and for a frequency of 50/60Hz.

Se garantiza el funcionamiento perfecto de todos los artículos Lucerni con una tensión de red comprendida entre 220v y 230v a una frecuencia de 50/60Hz

Bei einer Spannung zwischen 220v und 230v und einer Frequenz von 50/60 Hz wird der ordnungsgemäße Betrieb aller Lucerni-Artikel garantiert.

Le parfait fonctionnement de tous les articles Lucerni est garanti pour une tension de réseau comprise entre 220v et 230v à une fréquence de 50/60Hz.

Хорошая работа всех изделий Lucerni гарантируется при напряжении сети в пределах 220 и 230 в при частоте 50/60 гц.

Copyright© ottobre 2009 LAMPE s.r.l.
Tutti i diritti sono riservati. Nessuna parte di questa pubblicazione può essere riprodotta o trasmessa in qualsiasi forma e con qualsiasi mezzo senza il permesso scritto dell'editore.

Copyright © October 2009 LAMPE s.r.l.
All rights reserved. No part of this publication may be reproduced or transmitted in any form and any means without the written permission of the publisher.

Copyright © octubre 2009 LAMPE s.r.l.
Reservados todos los derechos. Esta publicación no puede ser reproducida, ni parcial ni totalmente, ni ser transmitida en ninguna forma ni por ningún medio, sin el permiso previo por escrito del editor.

Copyright © Oktober 2009 LAMPE s.r.l.
Alle Rechte vorbehalten. Kein Teil dieser Veröffentlichung darf ohne schriftliche Genehmigung des Herausgebers wiedergegeben oder auf beliebige Weise übertragen werden.

Copyright© Octobre 2009 LAMPE s.r.l.
Tous droits réservés. Aucune partie de cette publication ne peut être reproduite ou transmise quels que soient la forme et le moyen sans l'autorisation écrite de l'éditeur.

Copyright© Октябрь 2009 г. LAMPE s.r.l.
Все права охраняются законом. Ни одна часть данной публикации не может воспроизводиться или передаваться в какой-либо форме и каким-либо средством без письменного разрешения издателя.

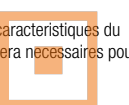
 **MODULO**
ELECTRO
www.modulelectro.ru