

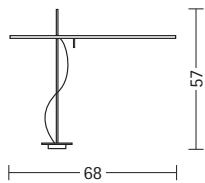

MODUL
ELECTRO

www.modulelectro.ru

49000
cromo chrome



1x11W w4,3

Lampadine incluse
Bulbs included

IP20 CE

Lampada da tavolo fluorescente. Struttura in metallo cromato.
Diffusore orientabile.
Fluorescent table lamp. Chromed metal structure. Directable
diffuser.
Lampe de table fluorescente. Structure en métal chromé.
Diffuseur orientable.
Leuchtstoff-Tischleuchte. Struktur aus verchromtem Metall.
Ausrichtbarer Diffusor.
Lámpara de mesa fluorescente. Estructura de metal cromado.
Difusor orientable.
Флуоресцентная настольная лампа. Структура из хромированного
металла. Регулируемый распределитель.



Movimenti della lampada.
How the lamp can be moved.
Comment orienter la lampe.

Bewegungsmöglichkeiten der Leuchte.
Movimientos de la lámpara.
Возможности вращения.

49204
alluminio aluminium

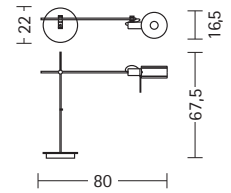

1x15W/41 E27 DULUX EL (1x100W E27)

Lampadine non incluse
Bulbs not included

IP20 CE

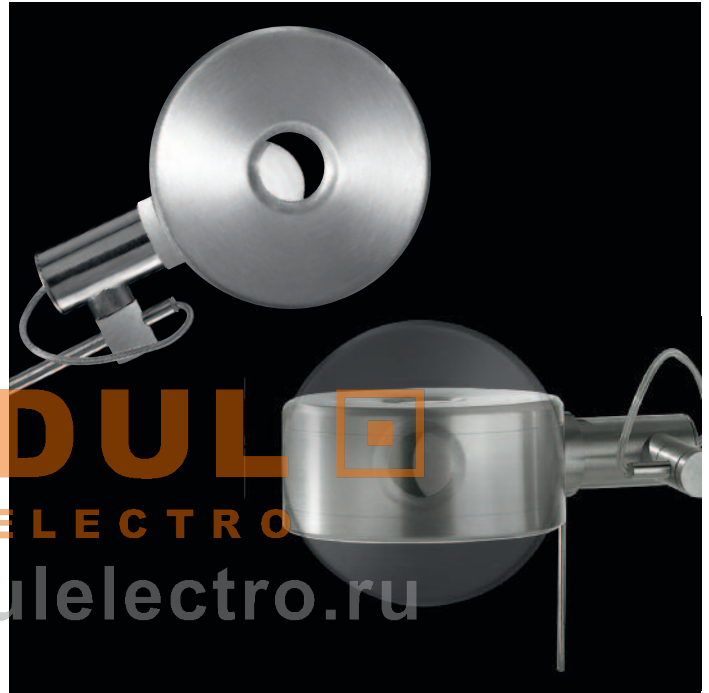

Lampada da tavolo a tensione di rete. Struttura in metallo cromato, elementi in alluminio spazzolato.

Mains-voltage table lamp. Structure in chrome-plated metal, elements in brushed aluminium.

Lampe de table à alimentation secteur. Structure en métal chromé, éléments en aluminium brossé.

Tischleuchten (Netzspannung). Struktur aus verchromtem Metall, gebürstetem Aluminium.

Lámpara de mesa directa a red. Estructura en metal cromado, elementos en aluminio cepillado.

Настольный светильник сетевого напряжения. Конструкция из хромированного металла, элементы из алюминия с отделкой «спаццолато»

Movimenti della lampada.

How the lamp can be moved.

Comment orienter la lampe.





MODUL
ELECTRO
www.modulelectro.ru

Bewegungsmöglichkeiten der Leuchte.
Movimientos de la lámpara.
возможности вращения.



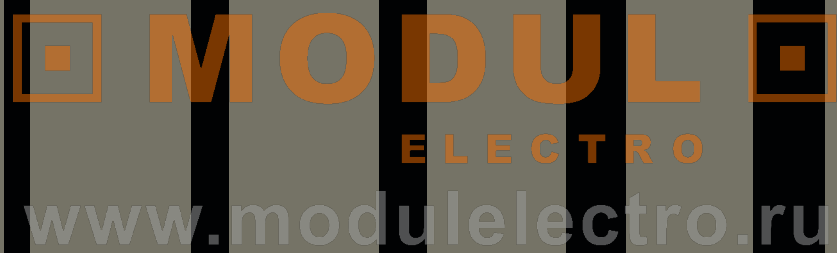

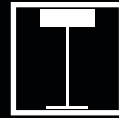

CONO	196
EOS	197
KAOS	192
MR. HYDE	188
NASTRO	186
OLIVIA	190
QUADRO	195
TOAST	194
ZERO	193

ELECTRO

www.modulelectro.ru



 **MODUL** 
ELECTRO
www.modulselectro.ru



- 45370 acciaio lucido polished steel
- 45371 acciaio satinato satin-finished steel
- 45372 acciaio nero black steel
- 45373 bianco white

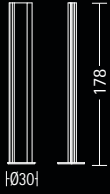

1x250W R7s 118mm
+
1x75W GZ10

Lampadine non incluse
Bulbs not included

IP20 CE

Lampada da terra a tensione di rete a doppia illuminazione. Struttura disponibile nelle versioni: acciaio lucidato, acciaio satinato, acciaio nero e verniciato bianco.

Mains voltage standard lamp, with double lighting. Structure available in the following versions: Shiny steel, satin-finish steel, black steel and painted white.

Lampe de sol à tension de réseau à éclairage double. Structure disponible dans les versions: acier brillant, acier satiné, acier noir et peint blanc.

Zweiflammige Standleuchte. Netzspannung. Lieferbar in verschiedenen Ausführungen: Stahl glänzend, Stahl satiniert, schwarz oder weiß lackierter Stahl.

Lámpara de pie con tensión de red con doble iluminación. Estructura disponible en las versiones: acero pulido, acero satinado, acero negro y pintado blanco.

Торшер на сетевом напряжении с двойным освещением. Структура выпускается в следующих вариантах: блестящая сталь, сатиновая сталь, черная сталь и окрашенная белая.



MODUL
ELECTRO
www.modulelectro.ru



MADE IN ITALY



MR. HYDE

JACCO BREGONJE 2009

51120 nero black

51121 rubino ruby red

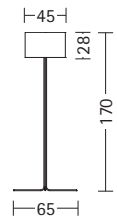

1x250W E27

Lampadine non incluse
Bulbs not included

IP20 CE



51120

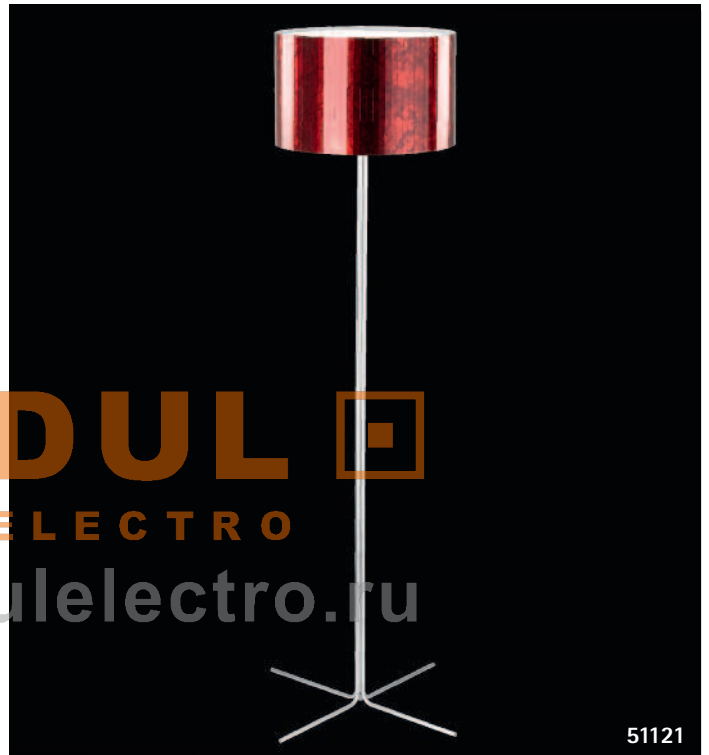

51121

MODULO
ELECTRO
www.modulelectro.ru

In collaborazione con
In collaboration with



Antique Mirror
Siena Tuscany

443

Lampada da terra a tensione di rete. Struttura in metallo verniciato. Diffusore in metallo accoppiato a mosaico (specchi Antique Mirror).
Mains voltage standard lamp. Structure in painted metal. Diffuser in metal combined with mosaic (Antique Mirror).
Lampe de sol à tension de réseau. Structure en métal peint. Diffuseur en métal peint associé à la mosaïque (miroirs Antique Mirror).
Standleuchte. Netzspannung. Lackierte Metallstruktur. Metallschirm mit Spiegelmosaik (Spiegel Antique Mirror).
Lámpara de pie con tensión de red. Estructura de metal pintado. Difusor de metal acoplado con mosaico (espejos Antique Mirror).
Торшер на сетевом напряжении. Структура из окрашенного металла. Рассеиватель из металла, соединенного с мозаикой (зеркала Antique Mirror).





MODUL
ELECTRO

www.modulelectro.ru

MADE IN ITALY



OLIVIA

ALESSANDRA GIPPONI 2009

45030 cromo lucido polished chrome

45031 argento silver

45032 bianco opaco matt white



1x200W R7s 118mm

Lampadine non incluse
Bulbs not included

IP20 CE

Lampada da terra a tensione di rete. Stelo in metallo e anello in alluminio pressofuso. Schermo diffusore metallico incluso.

Mains voltage standard lamp. Metal stem and die cast aluminium ring. Metal diffuser shield included.

Lampe de sol à tension de réseau. Tige en métal et cercle en aluminium moulé sous pression. Ecran diffuseur métallique inclus.

Standleuchte. Netzspannung. Metallständer und Ring aus Aluminiumdruckguss. Metallschirm inbegriffen.

Lámpara de pie con tensión de red. Columna de metal y anillo de aluminio fundido a presión. Pantalla difusora metálica incluida.

Торшер на сетевом напряжении. Шток из металла, кольцо из алюминия, полученного литьем под давлением. С металлическим экраном-рассеивателем.

ELECTRO
www.modulelectro.ru



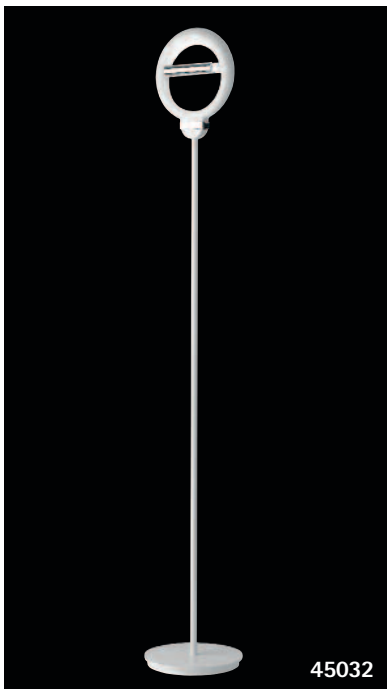
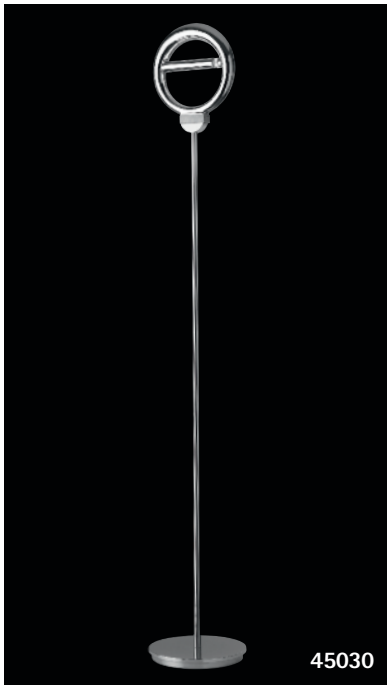



KAOS

Orazio Spada 2004

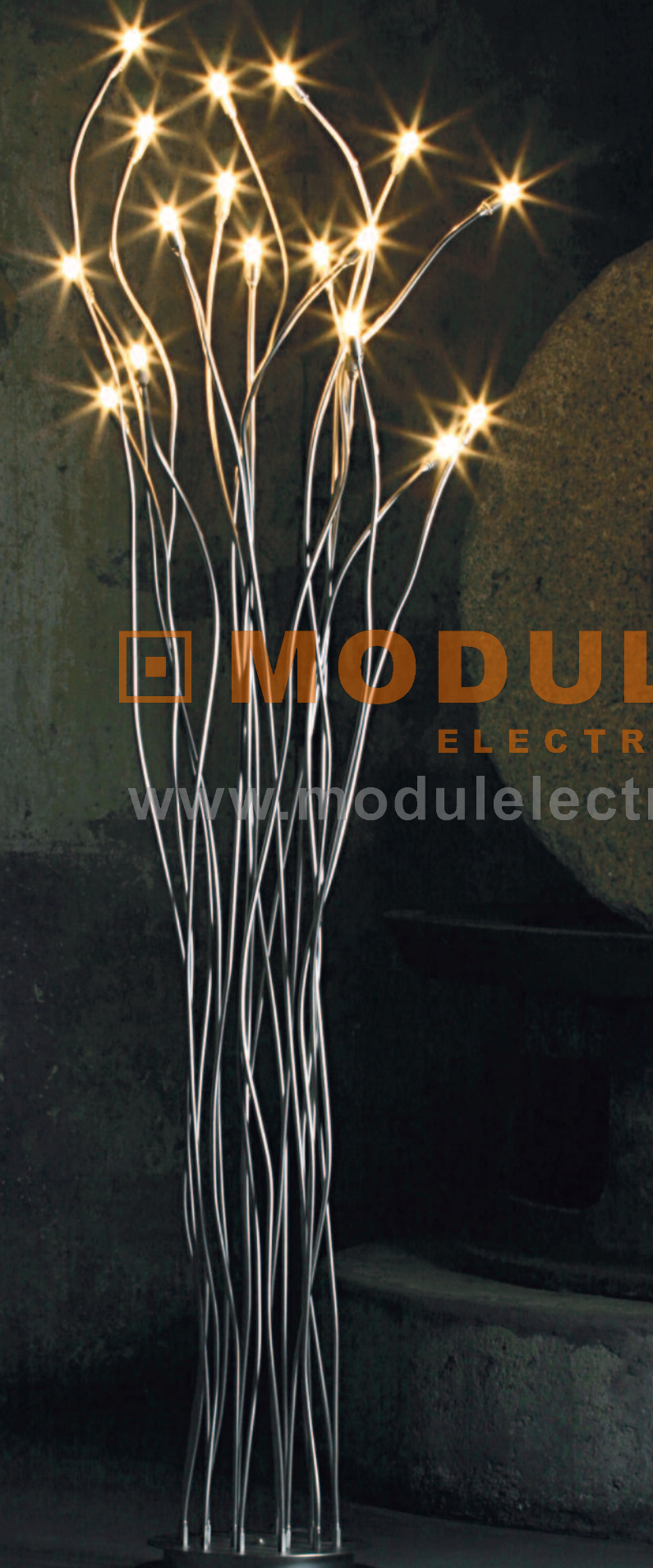

87035
nichel nickel



150i

18x25W G9 

Lampadine incluse
Bulbs included

  IP20 

Serie a tensione di rete. Struttura in rame nichelato.

Mains-voltage series. Nickel-plated copper structure.

Série tension secteur. Structure en cuivre nichelé.

Serie mit Netzspannung. Struktur aus vernickeltem Kupfer.

Serie a tensión de red. Estructura de cobre niquelado.

Серия, работающая при сетевом напряжении. Структура из никелированной меди.

 **MODUL** 
ELECTRO

www.modulelectro.ru



38



139

62028
cromo chrome

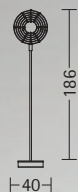

18x10W G4

Lampadine incluse
Bulbs included

IP20 CE

ZERO

Orazio Spada 2009



MODULO
ELECTRO
www.moduloelectro.ru

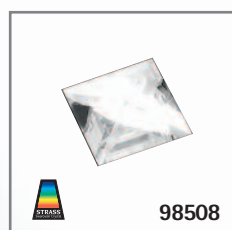

Confezione 5 Strass Swarovski.
Set made by 5 Swarovski Strass.
Boîte de 5 strass Swarovski.
Packing mit 5 Swarovski Strass.
Paquete de 5 Strass Swarovski.
Упаковка 5 стразов Swarovski.

Lampada da terra in bassa tensione. Alimentatore integrato.
Struttura in metallo cromato con apertura dei cerchi regolabile.
Low voltage standard lamp. Built-in feeder. Structure in
chromed metal with adjustable opening in hoops.
Lampe de sol à basse tension. Alimentateur intégré. Structure
en métal chromé avec ouverture réglable des cercles.
Standlampe. Niedervoltspannung. Eingebautes Netzteil.
Verchromte Metallstruktur mit Öffnung der verstellbaren Ringe.
Lámpara de pie de baja tensión. Alimentador integrado.
Estructura de metal cromado con apertura regulable de los aros.
Торшер низкого напряжения. Встроенный блок питания.
Структура из хромированного металла с регулируемым
открытием колец.





40010
cromo chrome

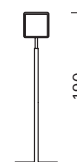

H 26 H

1x300W R7s 118mm 

Lampadine non incluse
Bulbs not included

  IP20 CE

Serie a tensione di rete. Struttura in metallo cromato. Diffusori in pirex satinato orientabili.

Mains-voltage series. Chromed-metal structure. Swivelling satin-finish pyrex diffusers.

Série tension secteur. Structure en métal chromé. Diffuseurs orientables en pyrex satiné.

Serie mit Netzspannung. Struktur aus verchromtem Metall. Ausrichtbare Diffusoren aus satiniertem Pyrex.

Serie a tensión de red. Estructura de metal cromado. Difusores de pirex satinado orientables.

Серия, работающая при сетевом напряжении. Структура из хромированного металла. Поворотные рассеиватели из полированного пирекса.

 **MODUL**
ELECTRO

www.modulelectro.ru



118



230V

233

44324 cromo lucido polished chrome
44326 cromo graffiato brushed chrome



H-28-H

1x300W R7s 118mm 

Lampadine non incluse
Bulbs not included

  IP20 CE

Serie a tensione di rete. Struttura in metallo cromato lucido o graffiato. Diffusore in pirex satinato.

Mains-voltage series. Polished or brushed chrome metal structure. Satin-finish pyrex diffuser.

Série tension secteur. Structure en métal chromé brillant ou strié. Diffuseur en pyrex satiné.

Serie mit Netzspannung. Struktur aus verchromtem Metall, poliert oder geritzt. Diffusor aus satiniertem Pyrex.

Serie a tensión de red. Estructura de metal cromado brillante o rayado. Difusor de pirex satinado.

Серия, работающая при сетевом напряжении. Структура из хромированного блестящего или матового металла. Распределители из полированного стекла «пирекс».

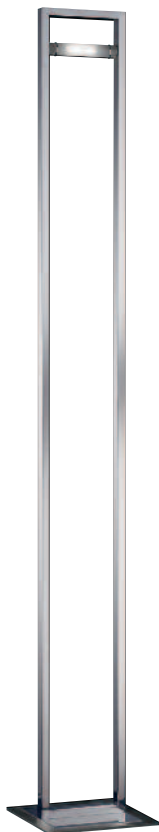

44324



72



108

MODUL 
ELECTRO

www.modulelectro.ru

50726
argento silver



1231

1x250W B15d 
Lampadine non incluse
Bulbs not included

  IP20 CE

Struttura in metallo e alluminio anodizzato. Diffusore in vetro.
Metal and anodised aluminium structure. Glass diffuser.
Structure en métal et aluminium anodisé. Diffuseur en verre.
Struktur aus Metall und eloxiertem Aluminium. Diffusor aus Glas.
Estructura de metal y aluminio anodizado. Difusor de cristal.
Структура из хромированного металла и блестящего алюминия. Стеклоянный рассеиватель.

www.modulelectro.ru



Lampadine
Bulbs



70



125



230V

225-233



438

32038
cromo chrome

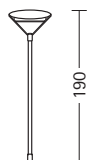

┌-34-┐

1x300W R7s 118mm 

Lampadine non incluse
Bulbs not included

  IP40 CE

Struttura in metallo cromato con
diffusore in pirex satinato.

Chromed-metal structure with satin-
finish pyrex diffuser.

Structure en métal chromé avec
diffuseur en pyrex satiné.

Struktur aus verchromtem Metall mit
Diffusor aus satiniertem Pyrex.

Estructura de metal cromado con difusor
de pirex satinado.

Структура из хромированного металла с
распределителем из полированного
стекла типа «пирекс».





120





230V
216

EOS
LIGHT LAB 1998

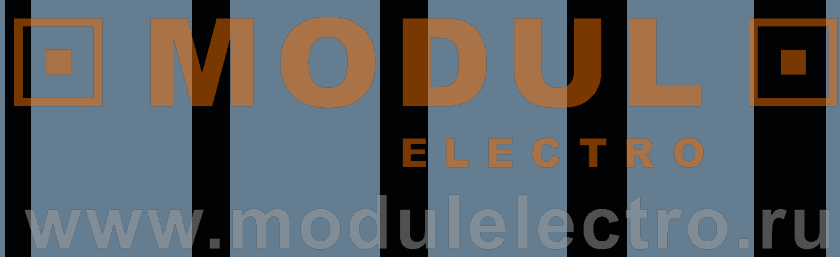

 **MODUL** 
ELECTRO
www.modulelectro.ru



 **MODUL** 
ELECTRO
www.modulelectro.ru

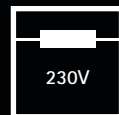

EOS
MICROEOS
PLUG-IN
SHOCK
ZEN

200
230
262
240
266



MODUL
ELECTRO

www.modulelectro.ru



MODULO
ELECTRO
www.modulelectro.ru

La serie "EOS" nasce per rispondere alle esigenze di designers e progettisti che desiderino mantenere un'alta flessibilità di installazione nel pieno rispetto delle caratteristiche architettoniche dell'ambiente. Per l'installazione non necessita di trasformatore.

The "EOS" series was designed to meet the requirements of designers and design engineers who need flexibility in the installation stage with full respect of the architectural characteristics of the environment. No transformer needed for installation.

La série "EOS" a été conçue pour les designers et les concepteurs qui souhaitent bénéficier d'une grande flexibilité au niveau de l'installation tout en respectant les caractéristiques architectoniques de la pièce. Le transformateur n'est pas nécessaire pour l'installation.

Die Serie "EOS" ist die Antwort für Designer und Entwerfer, die Wert auf Flexibilität bei der Installation unter gleichzeitiger Beachtung der architektonischen Merkmale des Ambiente legen. Für die Installierung ist kein Trafo notwendig.

La serie "EOS", nace para responder a las exigencias de designers y proyectistas que desean mantener una alta flexibilidad de instalación, respetando plenamente las características arquitectónicas del ambiente. Para la instalación no necesita transformador.

Серия "EOS" создавалась для удовлетворения потребностей дизайнеров и проектировщиков, которые хотят добиться повышенной гибкости при установке с полным сохранением архитектурных характеристик помещения. Для установки не требуется трансформатор.



MODUL

ELECTRO

www.modulelectro.ru

L32232

trasparente/satinato transparent/satin-finishing

EOS

MADE IN ITALY



MARCO SPADA 2009

MEASPC

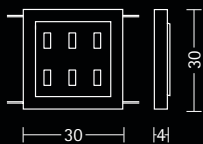
**Sorgente Lato LED**

Lato LED light source

LED bianco neutro

natural white LED ●

6 LED x 3,5W - 350mA



MODUL
ELECTRO
www.modulelectro.ru

Sorgente per sistema EOS, corpo in policarbonato finitura satinata. Colore LED bianco neutro. Alimentatori integrati. Tensione di alimentazione 220-240V.

Lighting source for EOS system, polycarbonate body with satin-finishing. Natural white coloured LED. Integrated power-supply. Power tension 220 - 240V.

Source pour système EOS, corps en polycarbonate finition satinée. Couleur de LED blanc neutre. Alimentateurs intégrés. Tension d'alimentation 220-240V.

Lichtquelle für das System EOS, PC-Gehäuse satiniert. LED - Farbe neutrales weiß. Eingebaute Netzteile. Anschlussspannung 220-240 V.

Fuente para sistema EOS, cuerpo de policarbonato acabado satinado. Color LED blanco neutro. Alimentadores integrados. Tensión de alimentación 220-240V.

Источник для системы EOS, корпус из сатинированного поликарбоната. Цвет СИД - белый нейтральный. Встроенные блоки питания. Напряжение питания 220-240 В.



244



EOS

MARCO SPADA 2005/2009

32243

satinato/cromo satin-finish/chrome

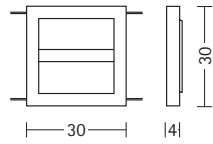

Sorgente Lato HQI
Lato HQI light source

2x20W PGj5

Lampadine non incluse
Bulbs not included



32233

satinato/cromo satin-finish/chrome

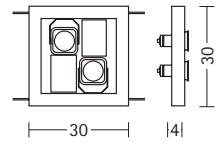

Sorgente Lato HQI
Lato HQI light source

2x35W GX10

Lampadine non incluse
Bulbs not included



32243



32233

www.modulelectro.ru

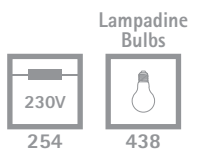



MODUL
ELECTRO

www.modulelectro.ru



MODUL
ELECTRO

www.modulelectro.ru

32232

satinato/cromo satin-finish/chrome

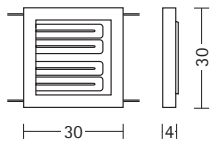

Sorgente Lato Fluo

Lato Fluo light source

2x36W 2G10 

Lampadine e diffusori 32173, 32174 e 32175 non inclusi
Bulbs and diffusers 32173, 32174 and 32175 not included

  IP20 

32238

satinato/cromo satin-finish/chrome

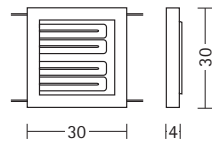

Sorgente Lato Fluo emergenza

Lato Fluo emergency light source

2x36W 2G10  + 1 LED x 3,5W - 350mA (emergenza emergency)

LED bianco neutro natural white LED 

Lampadine 2G10 e diffusori 32173, 32174 e 32175 non inclusi
Bulbs 2G10 and diffusers 32173, 32174 and 32175 not included

  IP20 

EOS

MADE IN ITALY



MARCO SPADA 2005/2009



32232



Tempo di ricarica Recharging time 24 h
Durata emergenza Emergency lenght 1h

32238

MODULO
ELECTRO
www.modulelectro.ru

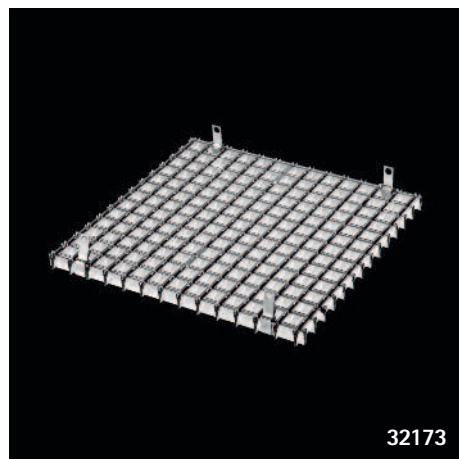

32173

32173

cromo chrome

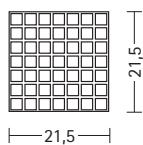

Schermo bassa luminanza per 32232.
Low luminance screen for 32232.

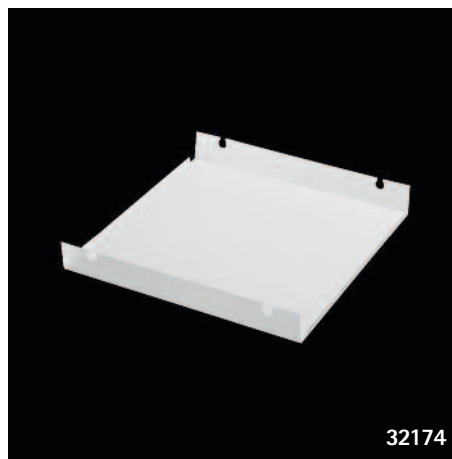

32174

32174

satinato satin-finish

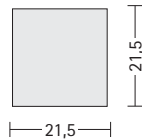

Diffusore policarbonato per 32232.
Polycarbonate diffuser for 32232.

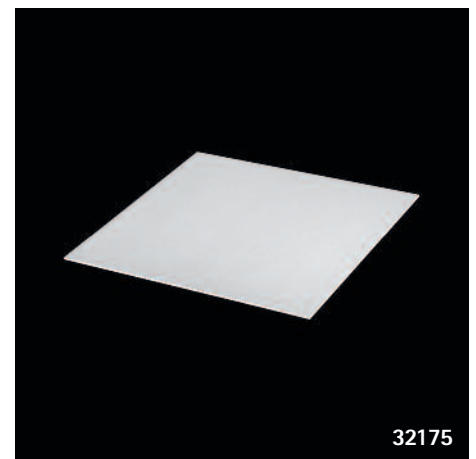

32175

32175

cromo chrome

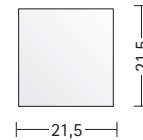

Riflettore per 32232.
Reflector for 32232.

Lampadine
Bulbs



438



78



248-270

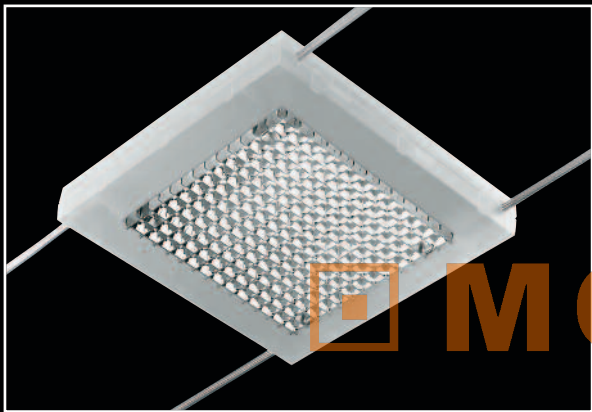
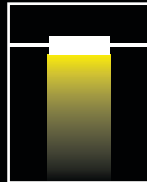
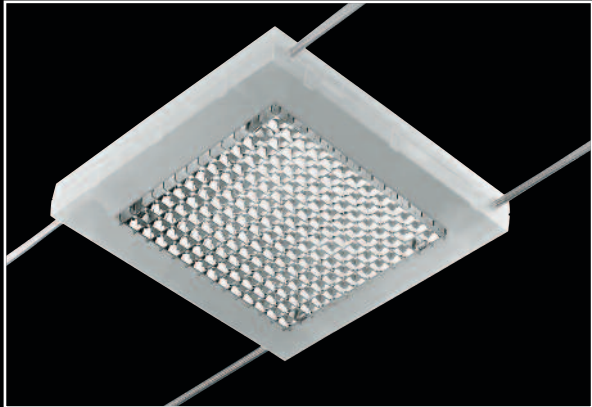

www.modulelectro.ru

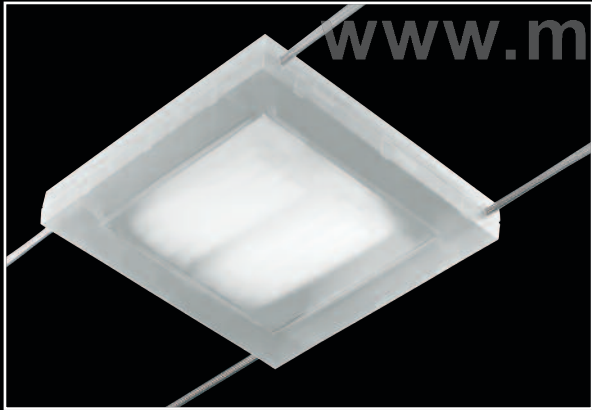

EOS

MADE IN ITALY

MARCO SPADA 2005/2009

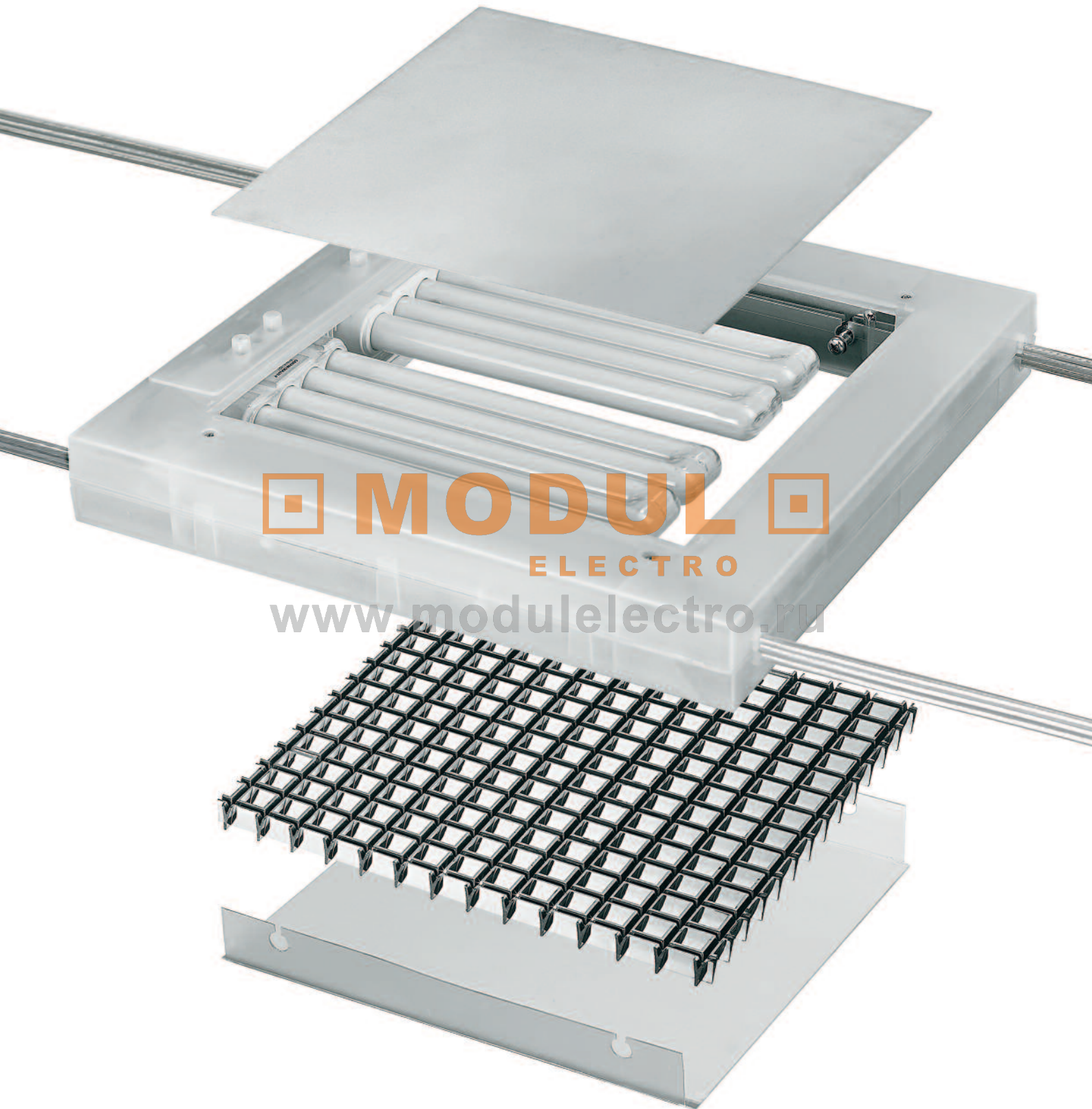

MODUL
ELECTRO

www.modulelectro.ru



EOS

LEO DE CARLO 2008

MEALSPO

32239

trasparente transparent

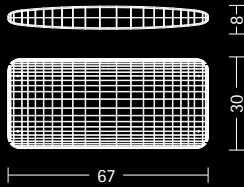

Sorgente COB

COB light source

2x55W 2G11 

Lampadine non incluse
Bulbs not included

  IP20 

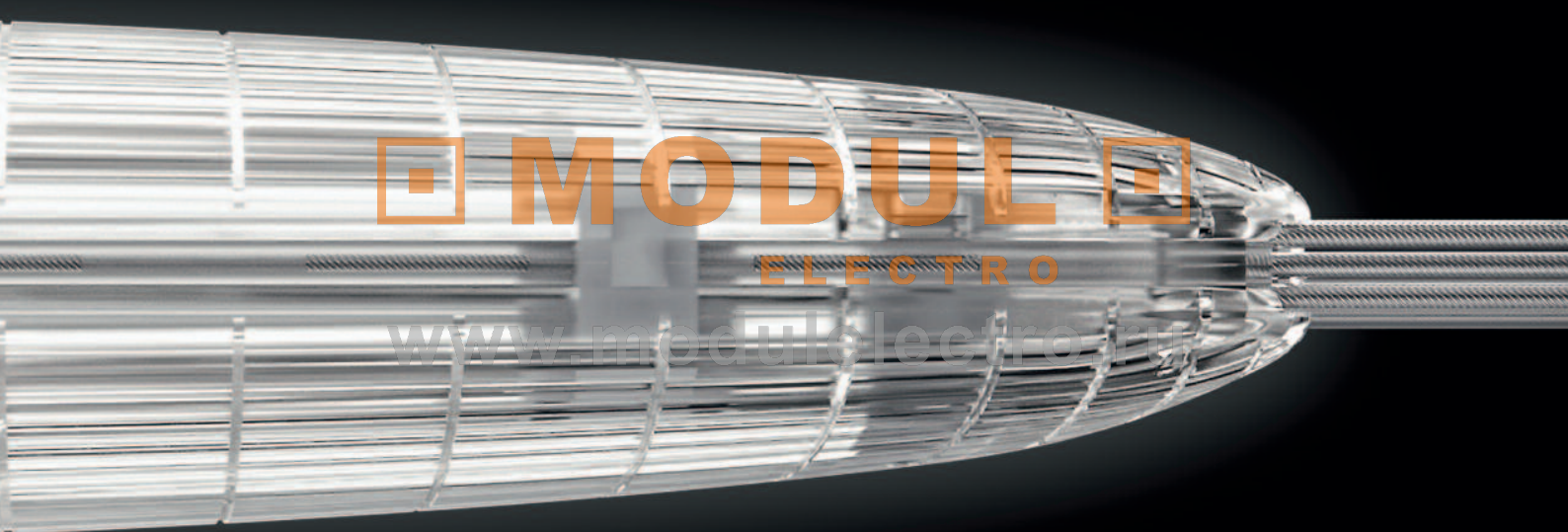

Sorgente con lampade fluorescenti per sistema EOS. Alimentatore elettronico incluso. Struttura-diffusore in policarbonato trasparente trattata attraverso prismaticatura interna per il miglioramento di entrambe le curve fotometriche (emissione trasversale e longitudinale). La prismaticatura è basata su un profilo opportunamente adattato nelle varie sedi rettangolari per tenere conto delle diverse posizioni delle superfici rispetto alle lampade.

Fluorescent lamp, source for EOS system. Electronic ballast included. Transparent prismatic polycarbonate structure-diffuser to improve both photometric curves (transversal and longitudinal emission). The prismatic process is based on a profile specifically modified for each rectangular piece taking into account the different settings of the surfaces and the positioning of the lamps.

Source avec ampoules fluorescentes pour système EOS. Alimentateur électronique inclus. Structure-diffuseur en polycarbonate transparent traité à travers une taille intérieure pour améliorer les deux courbes photométriques (émission transversale et longitudinale). La taille est basée sur un profil spécialement adapté dans les différentes embases rectangulaires pour tenir compte des différentes positions des surfaces par rapport aux ampoules.

Lampadine
Bulbs



80



164



230V



438



MODUL
ELECTRO
www.modulelectro.ru

Leuchte mit Leuchtstofflampen für EOS-System. Elektronisches Netzteil eingeschlossen. Diffusor-Gehäuse aus klarem Polycarbonat mit Prismenstruktur auf der Innenseite zur Verbesserung beider fotometrischer Kurven (Quer- und Längsausstrahlung). Die Prismenstruktur basiert auf einem den verschiedenen rechteckigen Gehäusen angepassten Profil, um den verschiedenen Positionen der Oberflächen zu den Lampen gerecht zu werden.

Luminaria de lámparas fluorescentes para sistema EOS. Alimentador electrónico incluido. Estructura-difusor de policarbonato transparente prismatizada internamente para mejorar las dos curvas fotométricas (haz transversal y longitudinal). La prismatización se basa en un perfil adecuadamente adaptado a los diferentes espacios rectangulares, para tener en cuenta las distintas posiciones de las superficies respecto a las lámparas.

Источник с флуоресцентными лампами для системы EOS. Включает электронный блок питания. Конструкция-рассеиватель из прозрачного поликарбоната с внутренними призмами для улучшения обоих фотометрических графиков (поперечное и продольное излучение). Призмы основаны на профиле, соответствующим образом подогнанном в различных прямоугольных гнездах, для учета различных положений поверхностей относительно ламп.



EOS

CLAUDIO ZAPPONE - GIORGIO PALERMO 2006/2009

32237 alluminio aluminium
32245 trasparente transparent

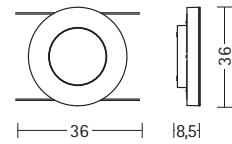

Sorgente GEODE
GEODE light source

1x55W 2GX13

Lampadine non incluse
Bulbs not included



MODULO
ELECTRO
www.modulelectro.ru

Guarnizione in PVC trasparente, giallo, rosso inclusa.
Transparent, yellow, and red PVC gasket included.
Joint en PVC transparent, jaune et rouge inclus.
Transparente, gelbe oder rote PVC-Dichtung inbegriffen.
Junta de PVC transparente, amarilla y roja incluida.
Прокладка из прозрачного, желтого и красного ПВХ.



Sorgente con lampada fluorescente. Struttura in PC verniciato, diffusore in policarbonato. Alimentatore elettronico. Disco centrale personalizzabile.

Lighting source fitted with fluorescent lamp. Structure in painted PC, polycarbonate diffuser. Electronic ballast. Central disk to be customized.

Source avec lampe fluorescente. Structure en PC verni, diffuseur en polycarbonate. Alimentation électronique. Disque central qui peut être personnalisé.

Leuchten für Leuchtstofflampe. Leuchtenkörper aus gefärbtem PC, Polycarbonat-Diffusor, EVG. Zentrale Scheibe kann mit Farbe individuell gestaltet werden.

Luminaria con lámpara fluorescente. estructura de PC pintado. Difusor en policarbonato. Alimentador electrónico. Disco central personalizable.

Серия с флуорисцентными лампами. Структура покрыта лаком PC, плафон выполнен из пластика (поликарбонат). Электронной балласт. Центральный диск может подвергаться изменениям.

Lampadine Bulbs



EOS

CLAUDIO ZAPPONE - GIORGIO PALERMO 2006/2009



MODUL
ELECTRO

www.modulelectro.ru



32054 argento silver 39W (cm. 92)
32153 argento silver 54W (cm. 122)
32214 emergenza emergency 39W

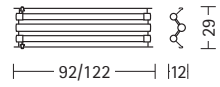

Sorgente Starglow
 Starglow light source

2x 39/54W G5 ←

Lampadine e diffusori non inclusi
 Bulbs and diffusers not included

 IP20 CE



32171 alluminio per aluminium for 32054
32172 alluminio per aluminium for 32153



32055 bianco per white for 32054
32145 bianco per white for 32153



32214
 emergenza emergency

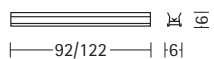

Ottica Dark (x2).
 Dark optics (x2).

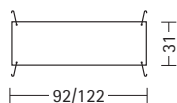

Diffusore policarbonato.
 Polycarbonate diffuser.

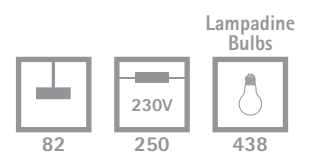

32156 39W (cm. 92)
 32157 54W (cm. 122)

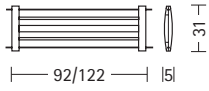

Sorgente Starvela
 Starvela light source

2x 39/54W G5 ←

Lampadine e diffusori non inclusi
 Bulbs and diffusers not included

 IP20 CE

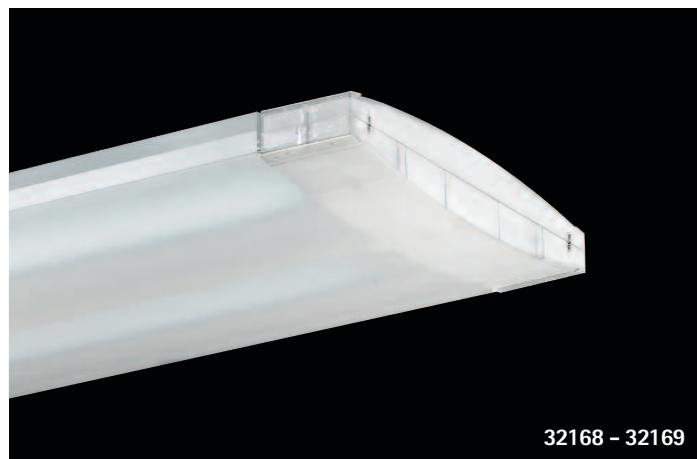
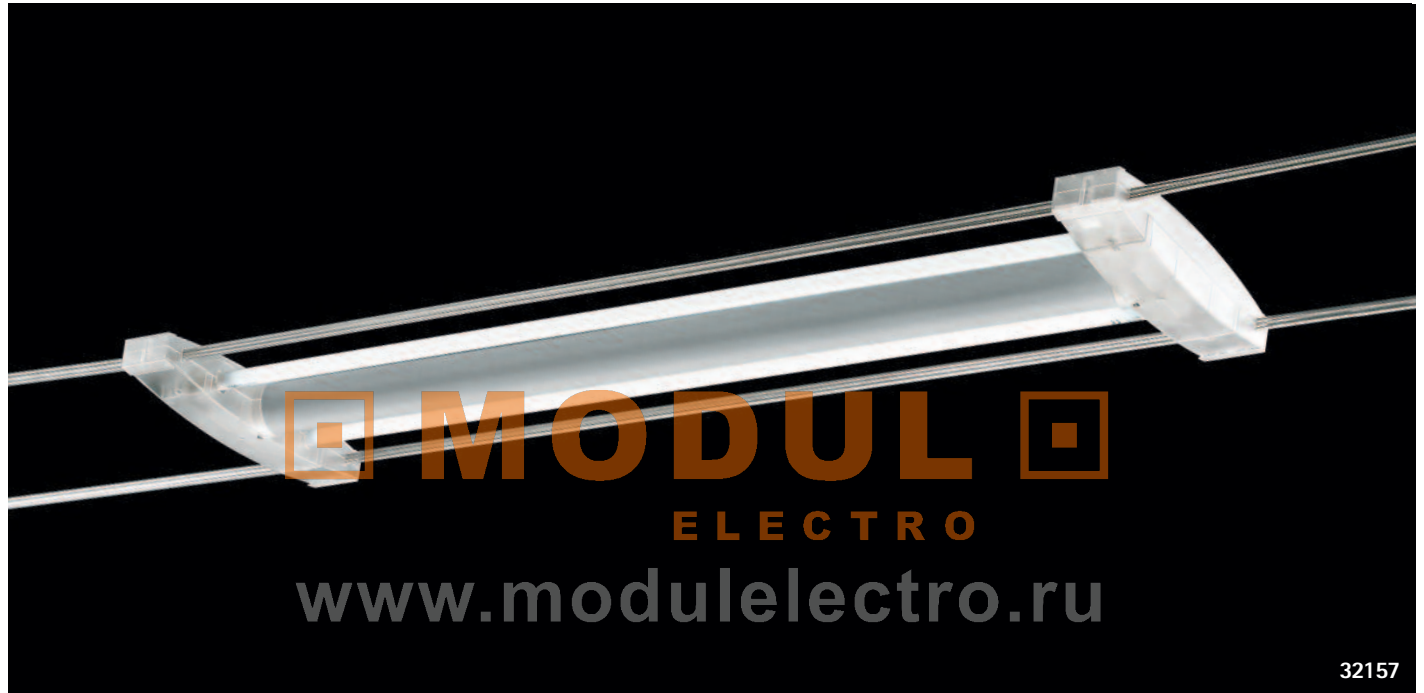

32168 bianco per white for 32156
 32169 bianco per white for 32157

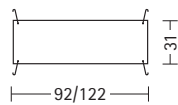

Diffusore policarbonato.
 Polycarbonate diffuser.

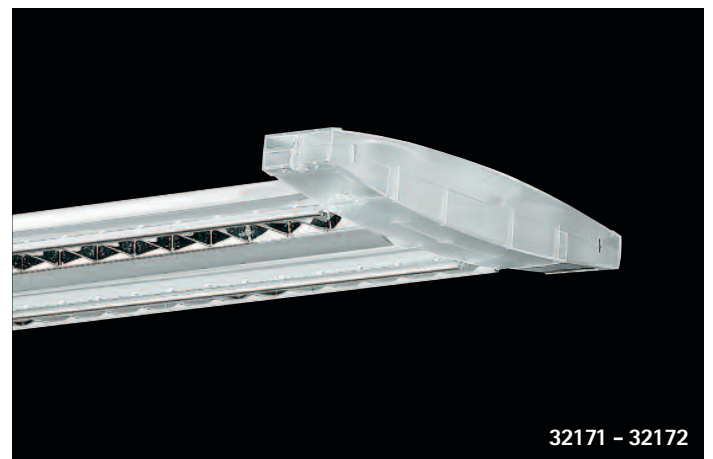

32171 alluminio per aluminium for 32156
 32172 alluminio per aluminium for 32157

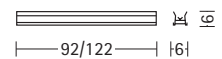

Ottica Dark (x2).
 Dark optics (x2).

Lampadine
 Bulbs





32020 satinato satin-finish
32024 satinato satin-finish 60%

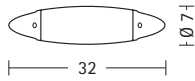

Sorgente Starfire
 Starfire light source

1x300W R7s 118mm

Lampadine non incluse
 Bulbs not included



32161
 satinato satin-finish

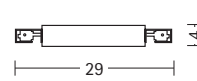

Sorgente Starzen
 Starzen light source

1x250W R7s 118mm

Lampadine non incluse
 Bulbs not included



32163
 satinato satin-finish

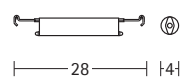

Sorgente Starzero
 Starzero light source

1x250W R7s 118mm

Lampadine non incluse
 Bulbs not included

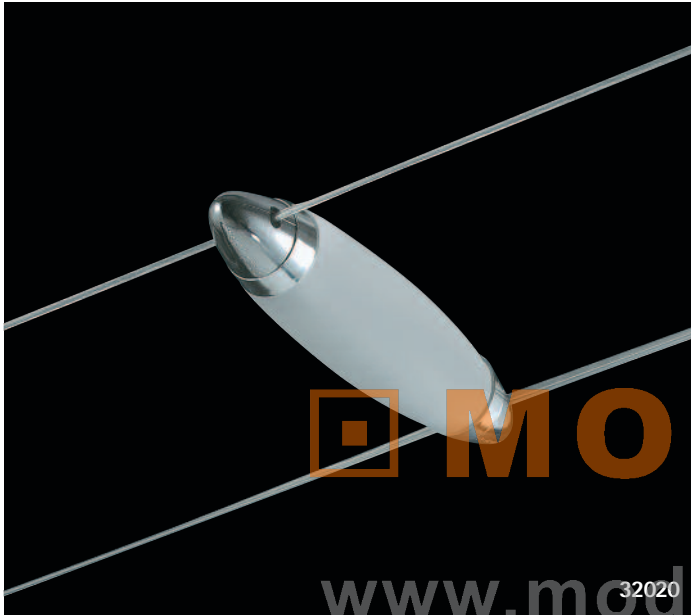

32020

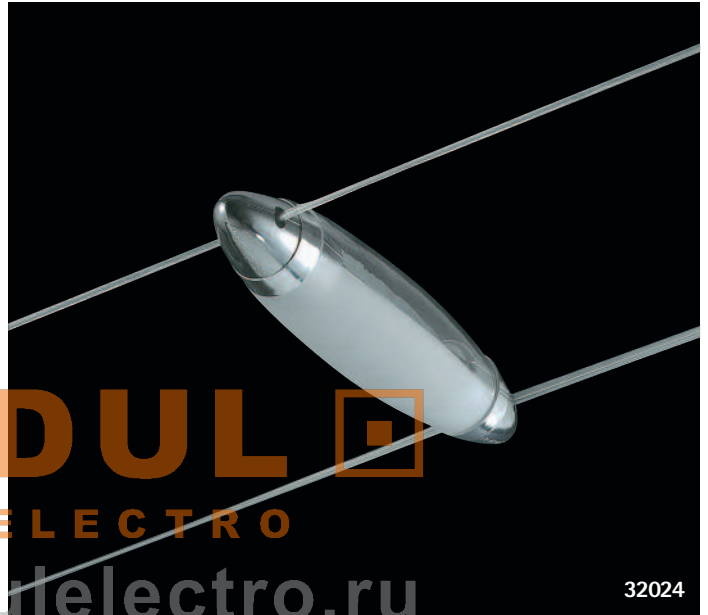

32024

MODULO
 ELECTRO
www.modulelectro.ru

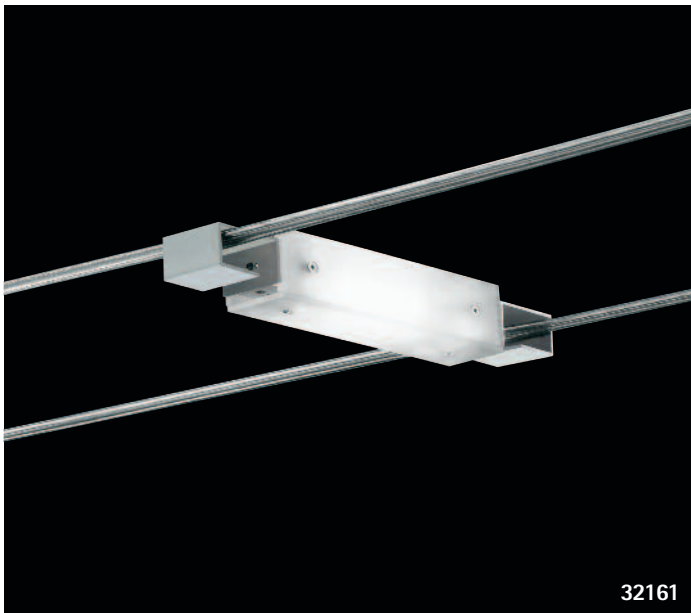

32161

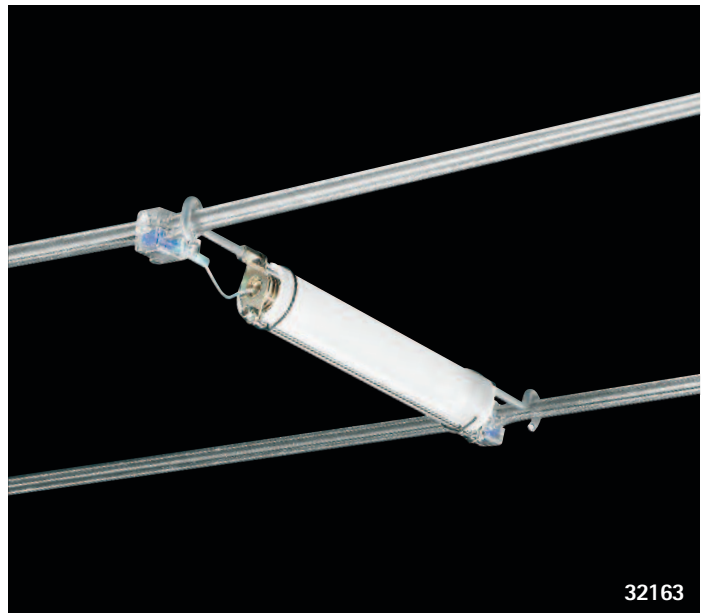

32163

MODUL

ELECTRO

www.modulelectro.ru





MODUL
ELECTRO

www.modulelectro.ru

32049 trasparente transparent
32051 satinato satin-finish

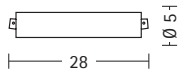

Sorgente Starhook
Starhook light source

1x250W R7s 118mm 

Lampadine e diffusore 32132 non inclusi
Bulbs and diffuser 32132 not included



32159 satinato/alluminio satin-finish/aluminium

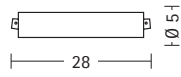

Sorgente Starhook
Starhook light source

1x250W R7s 118mm 

Lampadine e diffusore 32132 non inclusi
Bulbs and diffuser 32132 not included



32132 bianco white

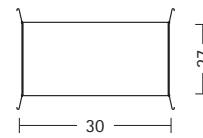

Diffusore policarbonato.
Polycarbonate diffuser.

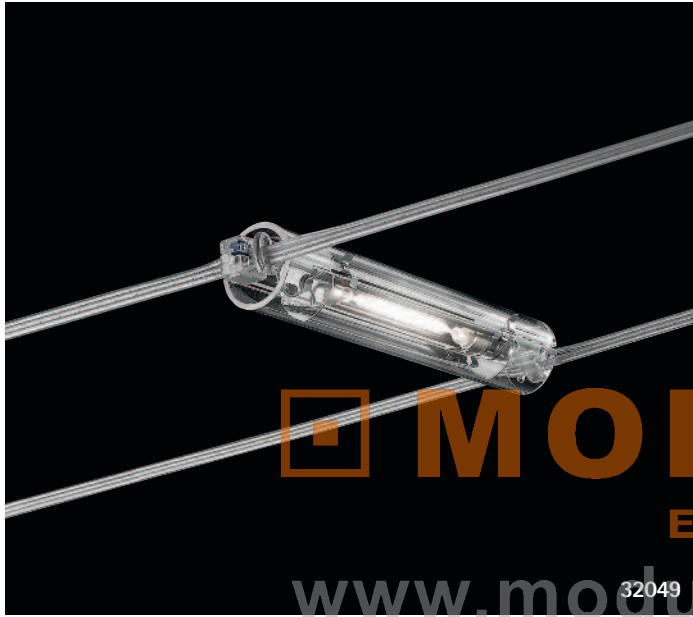

MODULO
ELECTRO
www.modulelectro.ru

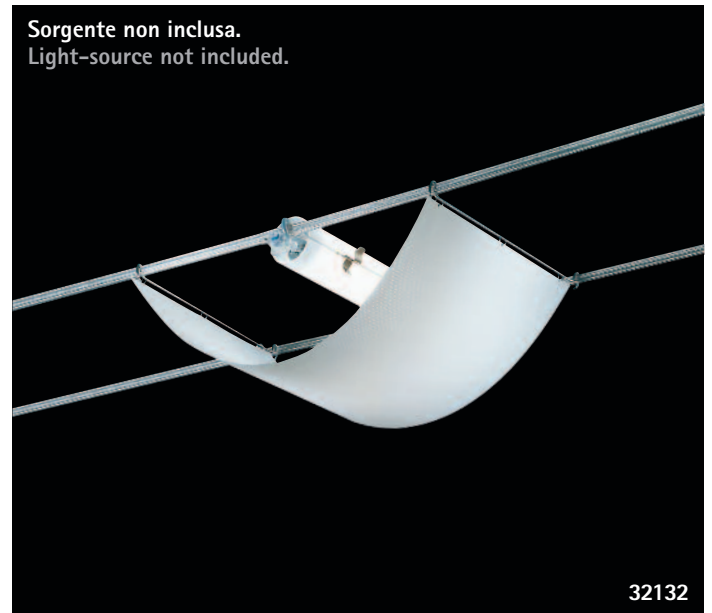
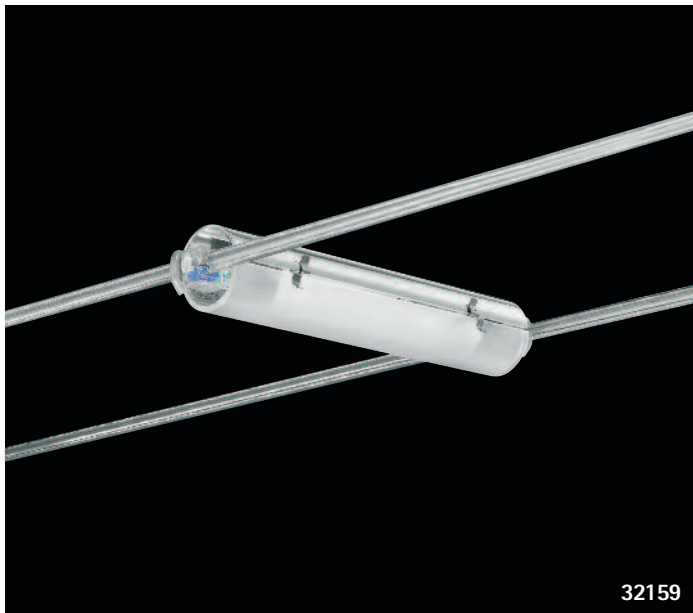

30072
 cromo chrome

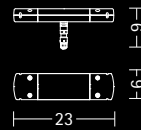

Adattatore Plug-in
 Plug-in Adapter

 IP20 CE

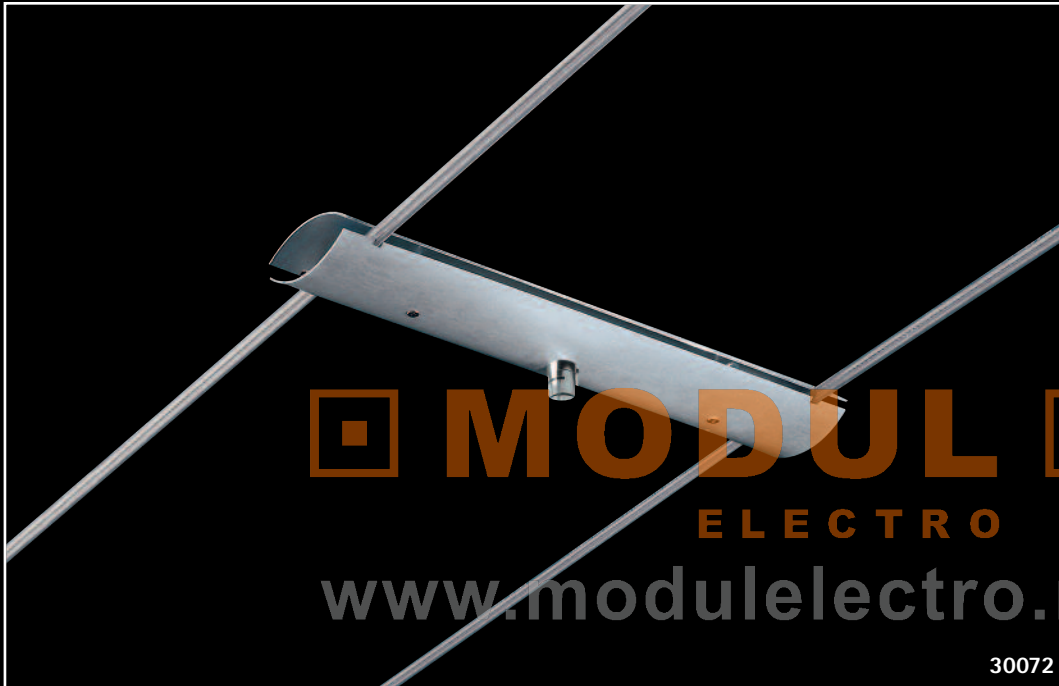

30072



Serie di apparecchi a tensione di rete.
 Mains-voltage series.
 Série d'appareils tension secteur.
 Serie Leuchtkörper mit Netzspannung.
 Serie de aparatos a tensión de red.
 Серия светильников, работающая при сетевом напряжении.

Modelli e accessori pag. 262-265
 Models and accessories page 262-265
 Modèles et accessoires page 262-265
 Modelle und Zusätze Seite 262-265
 Modelos y accesorios paginación 262-265
 модели и вспомогательное оборудование страница 262-265



MODUL
ELECTRO

www.modulelectro.ru

Innesto rapido 230V
230V fast connector





EOS

LIGHT LAB 2009

NEAISPOT

L32057
alluminio aluminium



30

Adattatore Starjack LED
Starjack LED adapter

IP20 CE

MODULO
ELECTRO

www.modulelectro.ru



Spot Jack LED utilizzabili con Starjack L32057. Jack LED spot lights suitable with Starjack L32057.

Spots Jack LED utilisables avec Starjack L32057. Spot-LED mit Klinkenstecker verwendbar mit Starjack L32057.

Spot Jack LED utilisables con Starjack L32057. Точечные СИД-светильники с штепсельным разъемом, используемые с Starjack L32057.



32057
argento silver

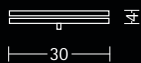

Adattatore Starjack
Starjack adapter

1x50W (230V/12V)

IP20 CE



MODUL
ELECTRO

www.modulelectro.ru

Spot Jack utilizzabili con Starjack 32057. Jack spot lights suitable with Starjack 32057.
Spots Jack utilisables avec Starjack 32057. Spot mit Klinkenstecker verwendbar mit Starjack 32057.
Spot Jack utilizables con Starjack 32057. Точечные светильники с штексельным разъемом, используемые с Starjack 32057.

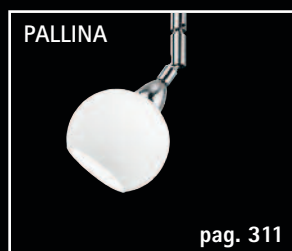
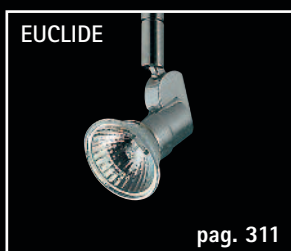
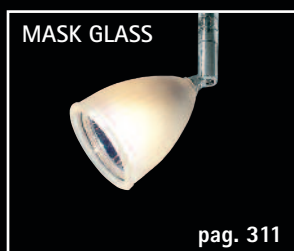
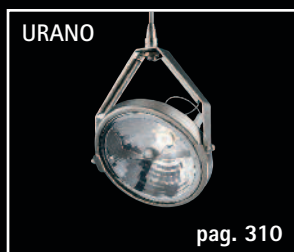
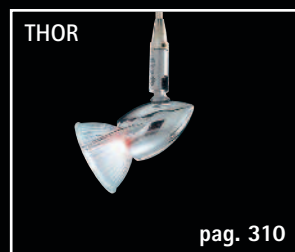



32234

32234

satinato/cromo satin-finish/chrome

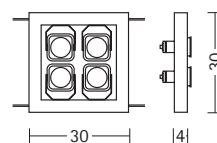
**Sorgente Lato GZ**

Lato GZ light source

4x50W GZ10 Lampadine non include
Bulbs not included

 IP20 CE

32026

32026

cromo chrome

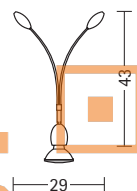
**Sorgente Starlet**

Starlet light source

1x100W E27 1x20W E27 DULUX EL REFLECTOR Lampadine non include
Bulbs not included

 IP20 CE

32150

32150

trasparente/alluminio transparent/aluminium

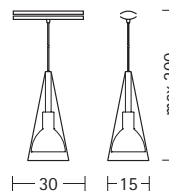
**Sorgente Starcono**

Starcono light source

1x100W B15d Lampadine non include
Bulbs not included

 IP20 CE
Lampadine
Bulbs