

HYDROLINE-B  
HYDROKUBO MEDIO  
HYDROKUBO MINI

 **MODUL**   
ELECTRO

[www.modulelectro.ru](http://www.modulelectro.ru)

**p.u.k.**<sup>®</sup>  
Sistemi Professionali per Illuminazione





**MODULO**  
ELECTRO  
[www.moduloelectro.ru](http://www.moduloelectro.ru)

all products in this catalogue, are: designed, engineered and made in Italy





**MODUL**

ELECTRO

[www.modulelectro.ru](http://www.modulelectro.ru)

...if you only could imagine, the right light!



**4 years**  
Long-life warranty

HYDROLINE 14/B  
a smart solution for your projects...

*Hydroline/B IP67* is the perfect solution to obtain pleasant and **soft lighting effects** on building walls, floors, cornices, profiles, window sills in public areas or private buildings perimeters both Outdoor or Indoor thanks to his **low visual impact**.

*Hydroline/B IP67* is complete with an electronic ballast and ready for parallel connection of several luminaires.



**MODUL**  
ELECTRO

[www.modulelectro.ru](http://www.modulelectro.ru)

- 230 V (220 → 240V) short circuit and overload protected
- 14 watt
- **Stainless steel** screws
- High corrosion resistance **die-cast aluminium body**
- Polyester painting with phosphocromating pre-finishing
- Clear tempered glass standard (completely frosted glass on request)
- Protection against impact **IK 10** (20 joule)
- T-5 **bulb G5** socket fluorescent
- Pg **13.5** cable gland (Ø 6÷12 mm wires)
- Unit Gross weight Kg 3,3

Warning! Always follow system standard rules when installing "Hydroline IP67".

HYDROLINE 14/B

# HYDROLINE 14/B

14 Watt max

T5 / G5 electronic

220-240 Volts / 50-60 Hz

IP67 - CE  

Clear glass standard  
(completely frosted glass on request)

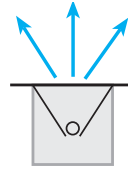

S = Symmetric reflector



HYDROLINE 14/B

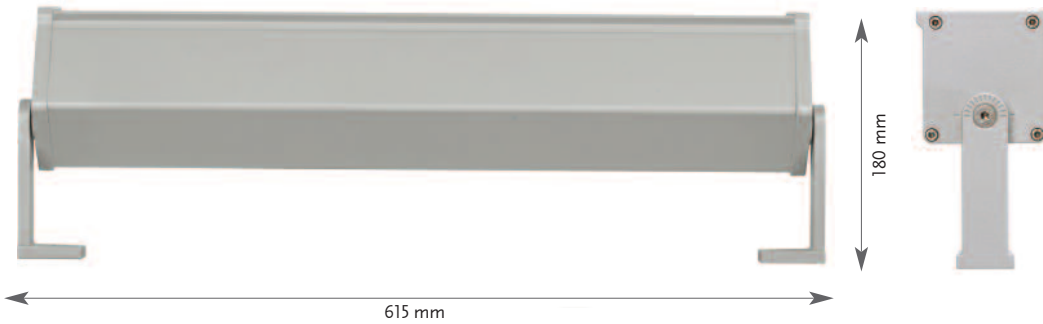

## MODUL

HL-01:  
Wall extensible bracket

Die-cast aluminum  
(option to be ordered separately)

ELECTRO Standard bracket (included)

[www.modulelectro.ru](http://www.modulelectro.ru)

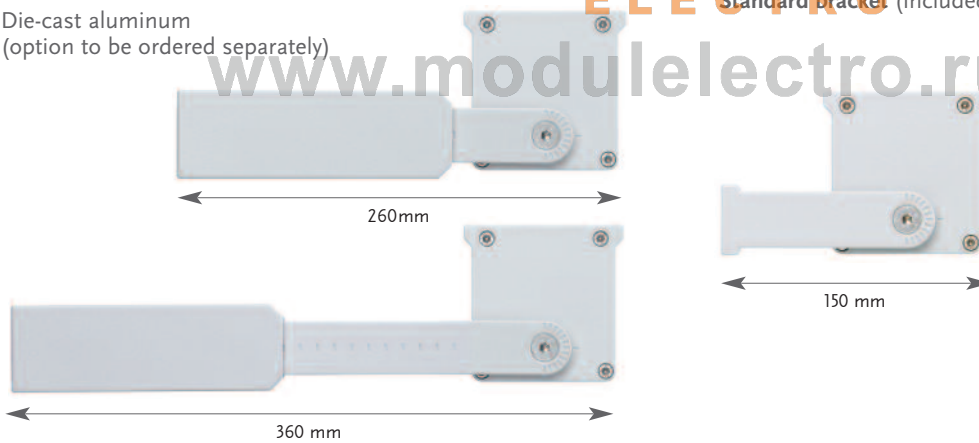

Easy and safe fixing

# HYDROLINE 14/B

**4 years**  
Long-life warranty

HYDROLINE 21/B  
a smart solution for your projects...

*Hydroline/B IP67* is the perfect solution to obtain pleasant and **soft lighting effects** on building walls, floors, cornices, profiles, window sills in public areas or private buildings perimeters both Outdoor or Indoor thanks to his **low visual impact**.

*Hydroline/B IP67* is complete with an electronic ballast and ready for parallel connection of several luminaires.



**MODUL**  
ELECTRO

[www.modulelectro.ru](http://www.modulelectro.ru)

- 230 V (220 → 240V) short circuit and overload protected
- 21 watt
- **Stainless steel** screws
- High corrosion resistance **die-cast aluminium body**
- Polyester painting with phosphochromating pre-finishing
- Clear tempered glass standard (completely frosted glass on request)
- Protection against impact **IK 10** (20 joule)
- T-5 **bulb G5** socket fluorescent
- Pg **13.5** cable gland (Ø 6÷12 mm wires)
- Unit Gross weight Kg 4,3

Warning! Always follow system standard rules when installing "Hydroline IP67".

# HYDROLINE 21/B

21 Watt max

T5 / G5 electronic

220-240 Volts / 50-60 Hz

IP67 - CE  

Clear glass standard

(completely frosted glass on request)

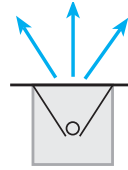

S = Symmetric reflector



HYDROLINE 21/B

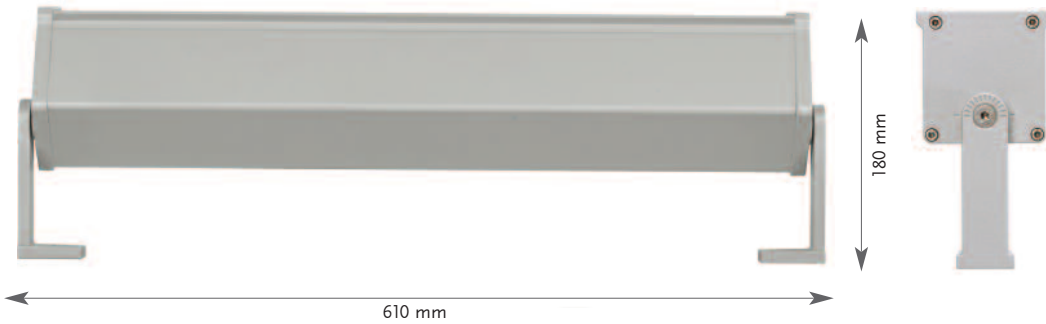

## MODULO

HL-01:  
Wall extensible bracket

Die-cast aluminum  
(option to be ordered separately)

ELECTRO Standard bracket (included)

[www.modulelectro.ru](http://www.modulelectro.ru)

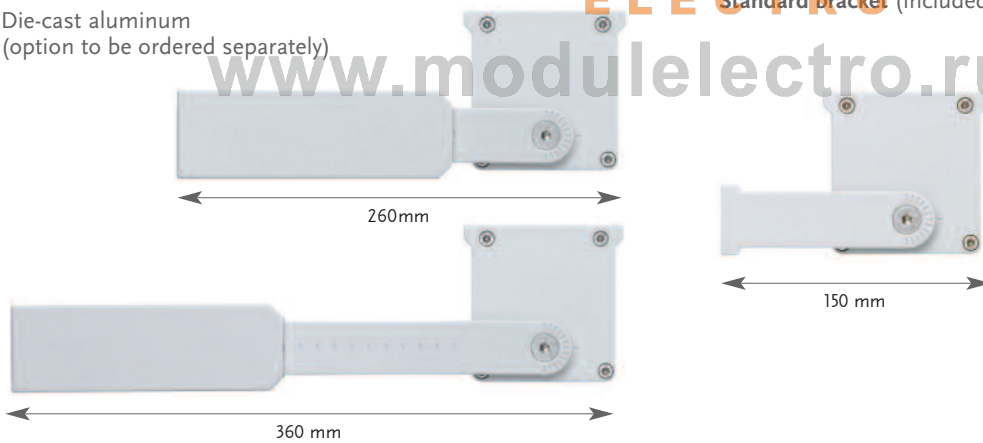

# HYDROLINE 21/B

# HYDROKUBO MINI/MEDIO

**4 years**  
Long-life warranty



HYDROKUBO MINI

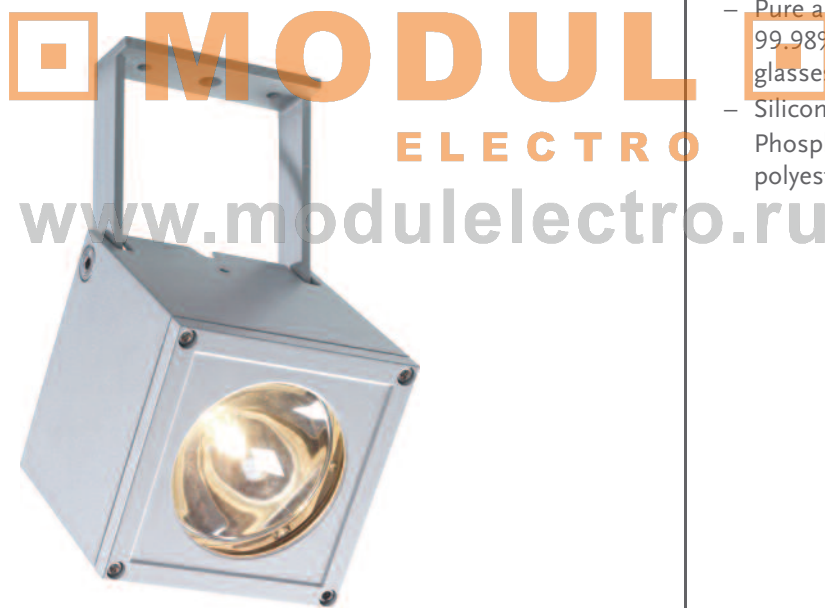

HYDROKUBO MEDIO

An "Hi-Tech" design, ultra compact but powerful fixtures range. Ideal for indoor and outdoor applications, with limited mounting area, or for accenting delicate architectural or landscape details.



The fully adjustable mounting stem, provides rotation for easy aiming.

Three main versions available:

Halogen 230 V GU 10,  
Halogen 12 V AR 111 and  
H.Q.I. metal halides.

- Completely made of die cast aluminium
- Integrated electronic components
- Pure aluminium reflectors 99.98% and tempered safety glasses
- Silicon rubber gaskets Phosphochromated and polyester painting

Available colours:

-  TEXTUR
-  MATT WHITE  
(ON REQUEST)
-  MATT BLACK  
(ON REQUEST)



**MODUL**  
ELECTRO  
[www.modulelectro.ru](http://www.modulelectro.ru)

HYDROCKUBO MINI/MEDIO



**4 years**  
Long-life warranty



An "Hi-Tech" design, ultra compact but powerful fixtures range. Ideal for indoor and outdoor applications, with limited mounting area, or for accenting delicate architectural or landscape details. The fully adjustable mounting stem, provides rotation for easy aiming.

HYDROKUBO MINI

**MODUL**  
ELECTRO

[www.modulelectro.ru](http://www.modulelectro.ru)

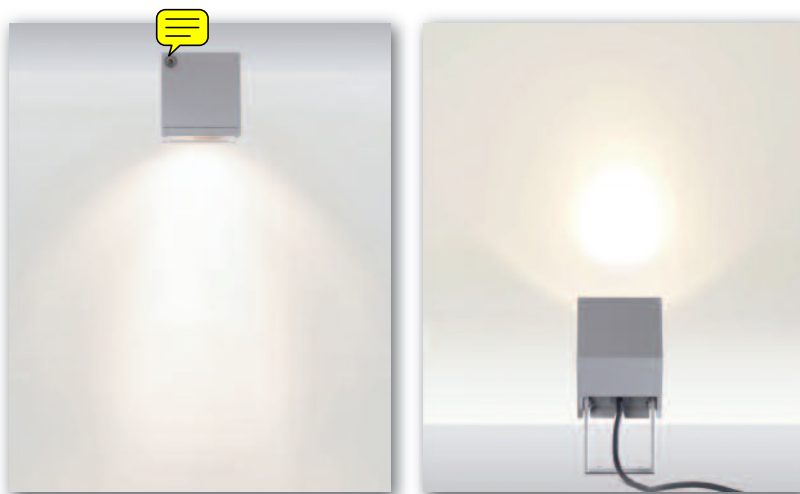

Lighting effects (Indoor or Outdoor)

Available colours:



TEXTUR



MATT WHITE  
(ON REQUEST)



MATT BLACK  
(ON REQUEST)



## HYDROKUBO MINI 01 - ES50

50 WATT MAX

QPAR 16 - BASE GU10

230 VOLTS conventional

IP65 - CE   

1,2 kg unit gross weight



ES50 - 230 Volts  
QPAR16



HYDROKUBO  
MINI  
01 - ES50

(3 Brackets always included)

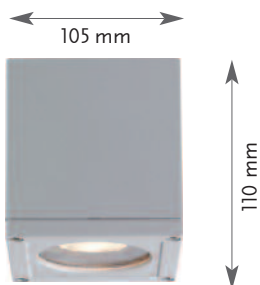

Ceiling Bracket (fix)



Wall Bracket (movable)

**MODULO**  
ELECTRO

[www.modulelectro.ru](http://www.modulelectro.ru)

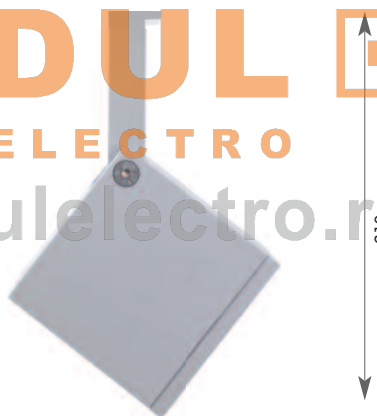

Ceiling/Wall/Ground Bracket (movable)

## HYDROKUBO MINI 02 - ES50

50 WATT MAX

QPAR 16 - BASE GU10

230 VOLTS Conventional

IP65 - CE   

3 kg unit gross weight



ES50 - 230 Volts  
QPAR16

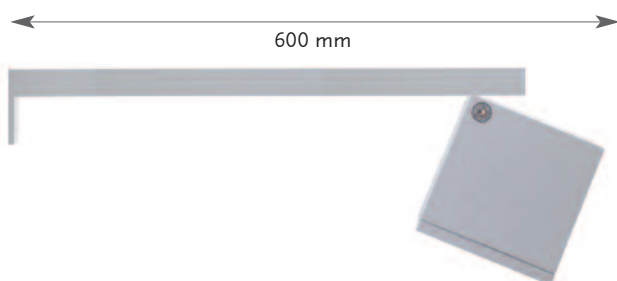

HYDROKUBO MINI

**4 years**  
Long-life warranty



HYDROKUBO MEDIO 01 - AR111

An "Hi-Tech" design, ultra compact but powerful fixtures range. Ideal for indoor and outdoor applications, with limited mounting area, or for accenting delicate architectural or landscape details. The fully adjustable mounting stem, provides rotation for easy aiming.

- Completely made of die cast aluminium
- Integrated electronic components
- Pure aluminium reflectors 99.98% and tempered safety glasses
- Silicon rubber gaskets Phosphochromated and polyester painting

**MODUL**  
ELECTRO

[www.modulelectro.ru](http://www.modulelectro.ru)

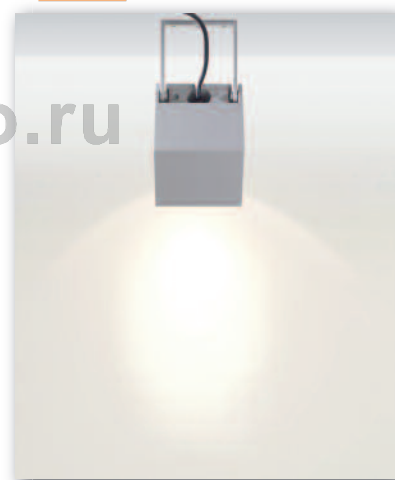

Available colours:



TEXTUR



MATT WHITE  
(ON REQUEST)



MATT BLACK  
(ON REQUEST)



## HYDROKUBO MEDIO 01 - AR111

50 WATT MAX

AR-111 - BASE G53

230 VOLTS Conventional

With transformer integrated

IP65 - CE ▽ ⊕

2,5 kg unit gross weight



AR-111 - Base G53



HYDROKUBO  
MEDIO  
02 - AR111

(3 Brackets always included)

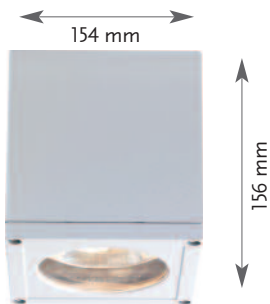

Ceiling Bracket (fix)



Wall Bracket (movable)

**MODULO**  
ELECTRO

[www.modulelectro.ru](http://www.modulelectro.ru)

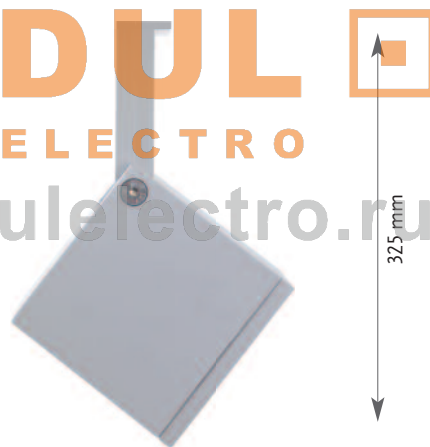

Ceiling/Wall/Ground Bracket (movable)

## HYDROKUBO MEDIO 02 - AR111

50 WATT MAX

AR-111 - BASE G53

230 VOLTS Conventional

With transformer integrated

IP65 - CE ▽ ⊕

4 kg unit gross weight



AR-111 - Base G53

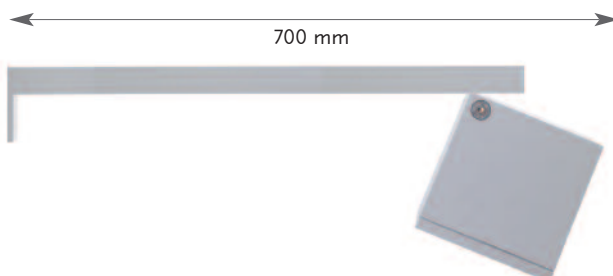

HYDROKUBO MEDIO

**4 years**  
Long-life warranty



HYDROKUBO MEDIO 01 - H.Q.I.

An "Hi-Tech" design, ultra compact but powerful fixtures range. Ideal for indoor and outdoor applications, with limited mounting area, or for accenting delicate architectural or landscape details. The fully adjustable mounting stem, provides rotation for easy aiming.

- Completely made of die cast aluminium
- Integrated electronic components
- Pure aluminium reflectors 99.98% and tempered safety glasses
- Silicon rubber gaskets Phosphochromated and polyester painting

**MODUL**  
ELECTRO

[www.modulelectro.ru](http://www.modulelectro.ru)

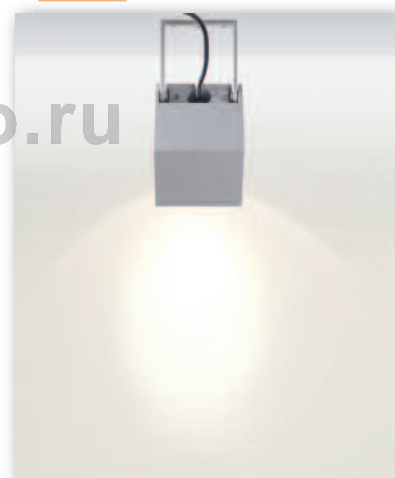

Available colours:



TEXTUR



MATT WHITE  
(ON REQUEST)



MATT BLACK  
(ON REQUEST)



## HYDROKUBO MEDIO 01 - H.Q.I. (spot 5°)

20 WATT MAX

BASE PGJ5

230 VOLTS Conventional

With ballast integrated

IP65 - CE ▽ ⊕

2,5 kg unit gross weight



CDM 20  
Base PGJ5



HYDROKUBO  
MEDIO  
02 - H.Q.I.

(3 Brackets always included)

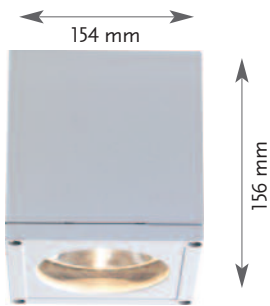

Ceiling Bracket (fix)



Wall Bracket (movable)

**MODULO**  
ELECTRO

[www.modulelectro.ru](http://www.modulelectro.ru)

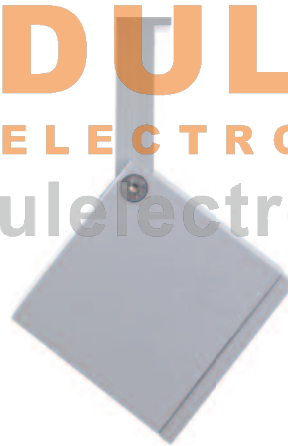

Ceiling/Wall/Ground Bracket (movable)

## HYDROKUBO MEDIO 02 - H.Q.I.

20 WATT MAX

BASE PGJ5

230 VOLTS Conventional

With ballast integrated

IP65 - CE ▽ ⊕

4 kg unit gross weight



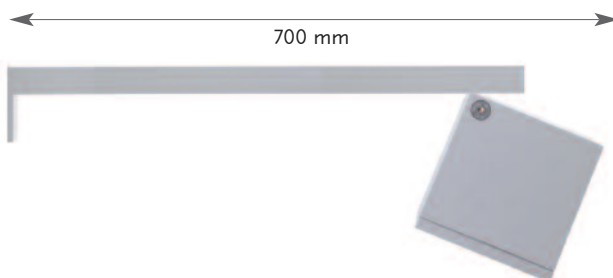

CDM 20  
Base PGJ5

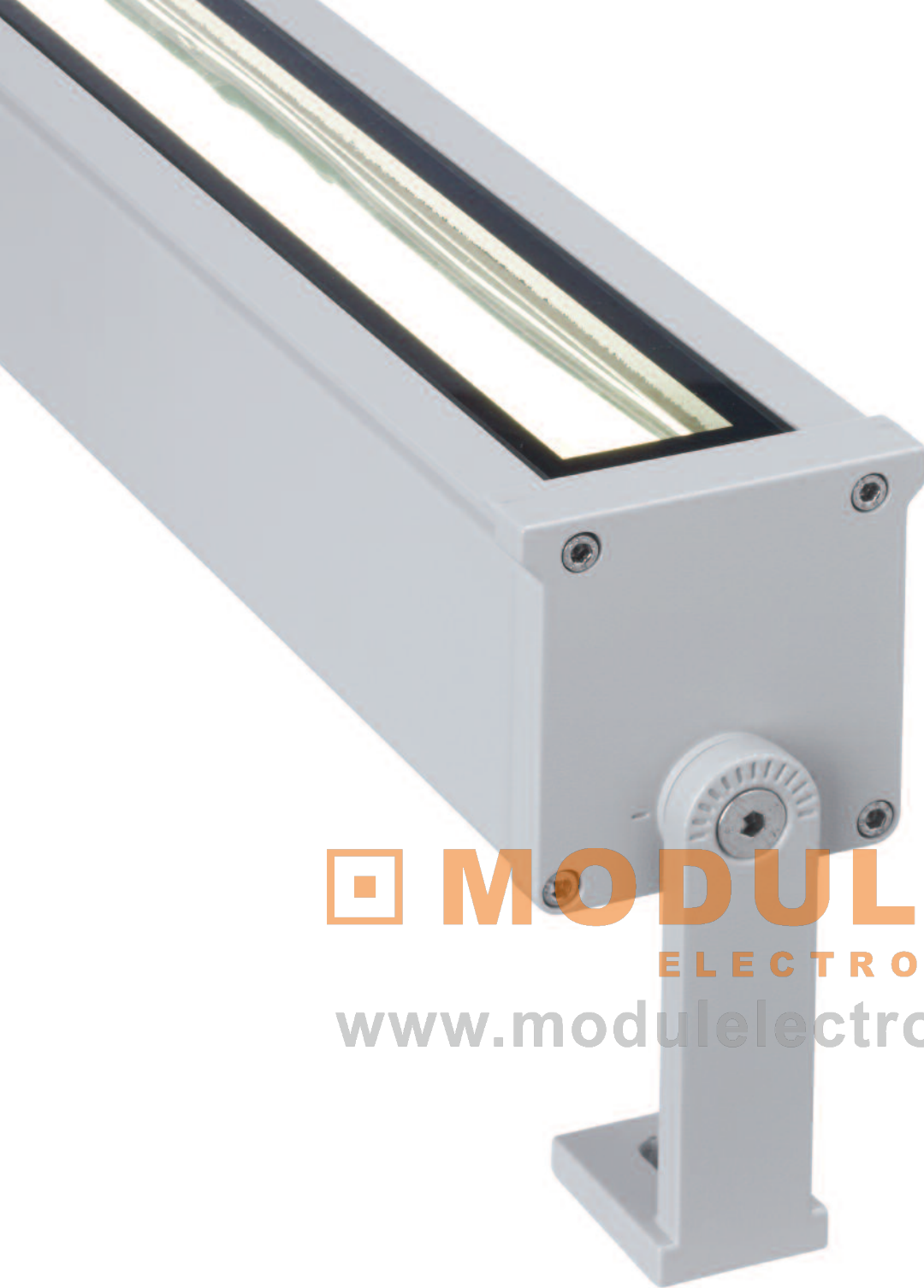

HYDROKUBO MEDIO



 **MODULO**   
ELECTRO  
[www.modulelectro.ru](http://www.modulelectro.ru)

All articles in this catalogue are made in Italy.  
All rights reserved

[www.puk.it](http://www.puk.it)

**p.uk.**<sup>®</sup>  
Sistemi Professionali per Illuminazione