

MODUL

ELECTRO

www.modulelectro.it

STUDIO

ITALIA

DESIGN

le origini - *the origin*

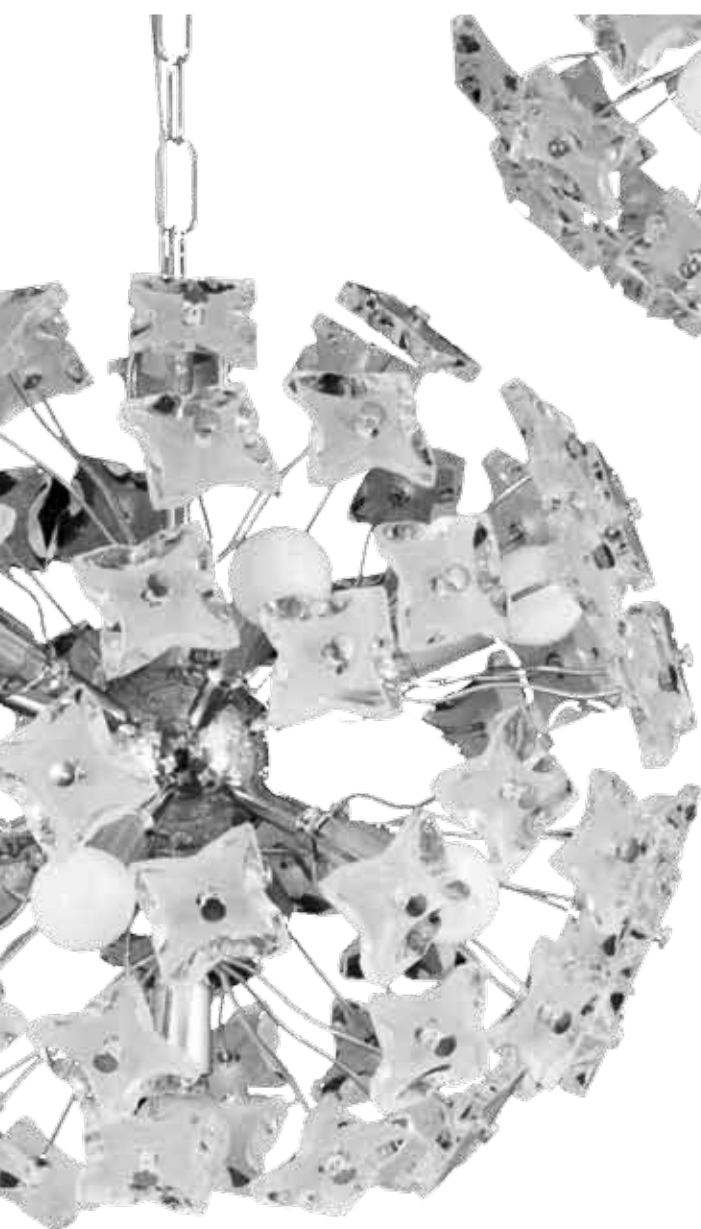

MODUL
ELECTRO
www.modulelectro.ru

In una bottega artigiana, a Marcon, nell'entroterra veneziano, alla fine degli anni '40, Angelo Tosetto progettava e realizzava impareggiabili lampadari artistici, incantevoli e di raffinata eleganza. Si recava a Murano per apprendere le tecniche di lavorazione dai maestri vetrai e carpirne i segreti. Attività appassionata e continua ricerca hanno segnato un rapido percorso che ha permesso di raggiungere prestigiosi riconoscimenti ed un pubblico internazionale.

At the end of the 40's in an artisan's workshop in Marcon in the Venice hinterland, Angelo Tosetto designed and manufactured enchanting chandeliers unequalled for their refinement and elegance. He would visit Murano to learn the techniques of working glass and to understand its secrets. His constant research and passion for the work soon brought him prestigious recognition from an international market.



passione e tradizione - *passion and tradition*

Oltre mezzo secolo di storia ed esperienze, la storia di tre generazioni che hanno portato Studio Italia Design ad affermarsi e distinguersi tra le più antiche e prestigiose aziende d'illuminazione nel panorama italiano.

Studio Italia design si distingue, infatti, per l'alta professionalità, la passione e la sensibilità con cui, legati alla tradizione, riescono a coniugare l'intramontabile arte vetreria muranese, a fonti luminose e metalli, proponendoli in una veste straordinariamente moderna e raffinata. La grande padronanza delle tecniche di lavorazione permette di assemblare materiali eterogenei realizzando così oggetti di stile contemporaneo custodi di un valore senza tempo.

Over half a century of history and experience, history of three generations that have carried studio italia design to qualify and distinguish itself amongst the oldest and most prestigious lighting companies on the italian scene.

It distinguishes itself for the high level of proffessionality, the passion and sensitivity which together with tradition, manage to marry the ageless art of murano glasswork to light sources and metals proposing an extrodinary piece of contemporary refinement. The mastery of these working techniques permit the bringing together of many diversities of materials to produce objects that still retain contemporary style whilst keeping timeless values.



MODULO
ELECTRO
www.modulelectro.ru





Le antiche sapienze, l'abilità artigiana si intrecciano a sperimentazioni, a continue ricerche ed innovazioni nel nuovissimo ed ampio stabilimento costituito da modernissimo show room, ufficio progettazione, commerciale, magazzini ed officine. Con il supporto di prestigiosi ed affermati progettisti, architetti e designers vengono realizzati oggetti esclusivi osservando criteri ed esigenze estetiche, tecniche e qualitative. Oggetti non solo come sorgente luminosa ma veri e propri complementi d'arredo, che con le loro trasparenze, giochi di luce, rifrazioni, rendono magico ogni tipo di ambiente. Un'evoluzione verso soluzioni architettoniche, dove fonti luminose all'avanguardia, moderne e innovative, materiale classico e metalli di altissima qualità entrano in sinergia, sviluppati con efficienza, professionalità e attenzione alle migliori tecniche di lavorazione.

Antique knowledge and artisan ability weave together with experimentation, continual research and innovation in our new and spacious buildings made up of a contemporary show room, design offices, sales offices, warehouses and workshops. With the support of prestigious architects and designers, we produce exclusive objects observing esthetic, technical and qualitative criteria. Objects that are not just lighting sources but that decorate and embellish with their transparency, use of light and refraction, they create magic in any environment. evolving towards architectural solutions where avant guard lighting sources, cutting edge and classic materials along with metals of the highest quality enter into a synergy developed with efficiency, professionalism and attention to the best working techniques.



MODULO
ELECTRO

www.modulelectro.ru



la ricerca - research

Studio Italia Design unisce con incomparabile abilità e maestria vari e pregiati materiali. Il vetro soffiato dialoga con ottone, alluminio, acciaio, esaltandone le potenzialità nelle diverse finiture. L'appassionato interesse per tutte le risorse della scienza e della tecnica determina nuove linee e nuove "raison d'être" esclusive, dettate dagli ambienti moderni, dalle attuali condizioni e stili di vita. I diversi elementi in un sottile gioco di equilibri e armonie creano effetti luminosi, volumetrici e lineari, espressioni di un'arte luminosa e illuminata rigorosamente Made in Italy. L'azienda avvalendosi di designer, ricercatori, creativi e grandi professionisti del settore, è in grado di soddisfare ogni esigenza, personalizzando ed elaborando modelli inediti e "sartoriali", per esaudire la committenza più esigente.

 **MODUL** 
ELECTRO
www.modulelectro.ru

 STUDIO
ITALIA DESIGN

Studio Italia Design brings together incomparable abilities and skills using precious materials, blown glass in dialogue with brass, aluminium and steel exalting the potential of the different finishes. The passionate interest for all the resources offered by science and technology determine new lines and new exclusive "raison d'être" dictated by modern environments and current conditions and life styles. The different elements in a subtle game of balance and harmony create lighting effects, volumetric and linear, expressions of a luminous and illuminated art, all rigorously "made in Italy" using designers, researchers, creators and great professionals in their fields, the company is capable of satisfying every requirement personalizing and engineering unique tailor made models for the most exacting projects.

Legenda

Legend - Légende - Legende - Leyenda







Montatura













































































Frame - Monture - Ausführungen - Soporte

Cr Cromo Chrome Chrome Chrom Cromo	Fu Fucsia Fuchsia Fuchsia Fuchsia Fuchsia
Gr Grigio Grey Gris Gris Gris	Aa Alluminio anodizzato Anodized aluminium Alu ciré Aluminium eloxiert Aluminio anodizado
Bk Bianco White Blanc Weiß Blanco	Al Acciaio lucido Polished steel Acier brillant Edelstahl glänzend Acero brillante
Rs Ruggine Rust Rost Rouille Orin	Sp Acciaio spazzolato Brushed steel Acier brossé Edelstahl gebürstet Acero cepillado
Ns Nickel spazzolato Brushed nickel Opeque nickel Nickel gebürstet Niquel cepillado	Is Inox spazzolato Brushed stainless steel Inox brossé Inox gebürstet Inox cepillado
Nr Nero Black Noire Schwarz Negro	Ye Giallo Yellow Jaune Gelb Amarillo
Nt Nickel satinato Satin nickel Nickel satiné Nickel satiniert Niquel satinado	Or Oro lucido Polished gold Or brillant Gold glänzend Oro brillante
NO Nero "soft touch" Black "soft touch" Noire "soft touch" Schwarz "soft touch" Negro "soft touch"	Ag Verde acido Acid green Vert acide Glseurtes Grün Verde acido

Diffusore

Diffuser - Diffuseur - Diffusor - Difusor

 000 Cristallo trasparente Clear crystal Cristal transparent Extrahelles kristallglas Cristal transparente	 027 Nero Black Noire Schwarz Negro
 010 Rosso Red Rouge Rotes, mundgeblasenes opalglas Rojo	 029 Ambra Amber Jaune Amber Ambar
 016 Bianco latte lucido Shiny milk white Blanc lait brilliant Weiß glänzend Blanco leche brillante	 030 Bianco latte satinato Etched milk white Weiß satiniert Blanco leche satinado
 017 Blu Darkblue Blue Blau Azul	 036 Lamiera microforata Micro-perforated metal Metal microperforé Geformtes Metal microhoradado
 038 Cristallo satinato Sanded crystal Crystal satiné Satiniertes kristallglas Cristal satinado	 060 Metallo specchiato Mirrored metal Metal miroir Spiegelmetall Metal espejado
 045 Arancione Orange Orange Orange Anaranjado	 039 Verde acido Acid green Vert acide Glseurtes Grün Verde acido
 047 Marrone lucido Shiny brown Marron brillant Braun glänzend Marron brillante	 050 Vetro specchiato Mirrored glass Verre miroir Spiegelglas Vidrio espejado

lampadina		watt	Eco
incandescenti - incandescent - sources incandescentes - glühlampen - incandescentes			
	Classic A60 (E27)	Classic A (E27)	60 - 75 - 100 - 150
	Halogen Classic A60 ECO (E27)	Halogen Classic A ECO (E27)	42 - 52 - 70 - 105 
	Classic A60 Silver (E27)	Decor Silver (E27)	100
	Globe G45 (E27)	Clas P (E27)	60
	Globe G45 (E14)	Clas P (E14)	60
	Classic C35 (E14)	Candela B (E14)	40 - 60
	R50 (E14)	Concentra Spot (E14)	40
alogene - halogen - halogènes - halogenlampe - halógena			
	Par 30 (E27)	Halopar 30 (E27)	75
	QT-32 (E27)	Halolux Ceram (E27)	100 - 150 - 200 - 230
	QT-32 ECO (E27)	Halolux Ceram ECO (E27)	70 - 100 - 150 - 205 
	QT-9 (G4)	Halostar 12Volt (G4)	20 - 35 - 50
	Decopin (G9)	Decopin (G9)	40
	QT-14 (G9)	Halopin (G9)	40 - 60 - 75
	QT-14 ECO (G9)	Halopin ECO (G9)	33 - 48 - 60 
	AR111 (G53)	Halospot 111 12Volt (G53)	50 - 100
	MR11 (GU4)	Decostar 35 S 12Volt (GU4)	20 - 35
	MR16 (GU5,3)	Decostar 51 S 12Volt (GU5,3)	35 - 50
	Par 16 (GU10)	Halopar 16 (GU10)	50
	Par 20 (GU10)	Halopar 20 (GU10)	75
	QT-DE12 short (R7s)	Haloline Longlife 78mm (R7s)	150 - 200
	QT-DE12 short ECO (R7s)	Haloline ECO 78mm (R7s)	120 - 160 
	QT-DE12 long (R7s)	Haloline Longlife 118mm (R7s)	150 - 200 - 300
	QT-DE12 long ECO (R7s)	Haloline ECO 118mm (R7s)	120 - 160 - 230 
fluorescenti - fluorescent - sources fluorescentes - leuchtstofflampen - fluorescentes			
	CFL Square (GR10q)	CFL Square (GR10q)	16 
	T5 HO (G5)	Lumilux T5 HO FQ (G5)	24 - 54 - 80 
	T5 HO SeamLess (G5)	Lumilux T5 SeamLess (G5)	39 
	T5 HO [Red-Green-Blue] (G5)	T5 HO FQ [Red-Green-Blue] (G5)	80 
	T5 HE (G5)	Lumilux T5 HE FH (G5)	28 
	T2 (W4,3)	Lumilux T2 FM (W4,3)	13 
	T5 Circline (2GX13)	Lumilux T5 FC (2GX13)	22 - 40 - 55 
	TC-DEL (G24q-2)	Dulux D/E (G24q-2)	18 
	TC-DEL (G24q-3)	Dulux D/E (G24q-3)	26 
	TC-TEL (GX24q-2)	Dulux T/E (GX24q-2)	18 
	TC-TEL (GX24q-3)	Dulux T/E (GX24q-3)	26 
	TC-TEL plus (GX24q-4)	Dulux T/E plus (GX24q-4)	42 
	CFL (GU10)	Reflector (GU10)	11 
	CFL (GX53)	CFL (GX53)	9 - 13 
	TC-F (2G10)	Dulux F (2G10)	36 
	TC-L (2G11)	Dulux L (2G11)	36 - 55 - 80 
	TC-TSE (E27)	Dulux EL (E27)	12 - 16 - 21 - 24 - 30 
led (light emitting diode)			
	Optospot OSP (I)	Optospot OSP/LF45/L3 350mA(I)	4,5 
	Dragon-X L12W (I)	Dragon-X L12W 350mA (I)	1,2 
	Dragon-X L60W (I)	Dragon-X L60W 350mA (I)	1,2 
	MR16 CREE (GU5,3)	MR16 (GU5,3)	7 
	AR111 Led (G53)	AR111 Led 12-24Volt (G53)	10 
	Citizen Led (I)	Citizen Led (I)	3 
alogenuri metallici - metal halide - halogénures métalliques - Metaldampflampen - halogenuros metálicos			
	HIR-CE111 (GX8,5)	HCI R111 (GX8,5)	35
	HIT-DE (RX7s)	Powerball HCI-TS (RX7s)	70



A-Tube
pg. 24



Amourette
pg. 32



Andrei
pg. 34



Bell
pg. 38



Clessidra
pg. 50



Curl my light
pg. 54



Flat
pg. 58



Lace
pg. 72



Laser
pg. 74



Lole
pg. 76



Maya
pg. 86



Nuvola
pg. 88



Ovì
pg. 94



Alba
pg. 28



Aloha
pg. 30



Big-mec
pg. 40



Bubble
pg. 46

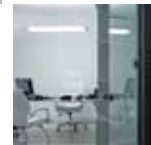

Fly
pg. 60



Kapp
pg. 68



Mania
pg. 82

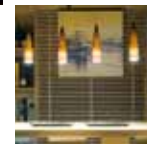

Mania V
pg. 84



Soap
pg. 104



Surf
pg. 108



Tris
pg. 120

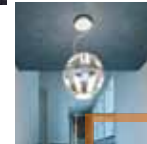

Ufo
pg. 124



Playa
pg. 96

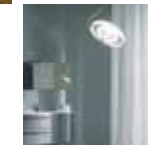

Puraluce
pg. 98



Rondò
pg. 102

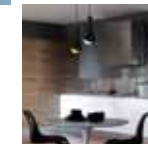

Trunk
pg. 112

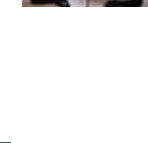

Trilogy
pg. 116

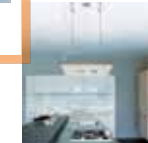

Zen
pg. 130

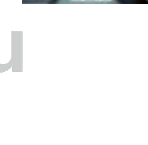

Zen V
pg. 134

MODULO
ELECTRO

www.modulelectro.ru



A-Box
pg. 144

B-Box
pg. 154

Bubble
pg. 156

Clessidra
pg. 158

Fly
pg. 166

Incanto
pg. 168

Inpiano
pg. 170

Laser
pg. 184

Laser cube
pg. 188

Mabel
pg. 196

Maya
pg. 202

Minimania
pg. 204

Alba
pg. 150

Andrei
pg. 152

Crypto
pg. 162

Electra
pg. 164

Kapp
pg. 174

Lancia
pg. 180

Ludo
pg. 194

Ombra
pg. 212

Polis
pg. 216

Prima
pg. 218

Puraluce
pg. 220

Sail
pg. 224

Sail V
pg. 226

Sax
pg. 228

Slim
pg. 232

Snake
pg. 234

Sophie
pg. 238

Spotty
pg. 240

Square
pg. 242

Tris
pg. 244

Zen
pg. 248

MODULO
ELECTRO

www.modulelectro.ru

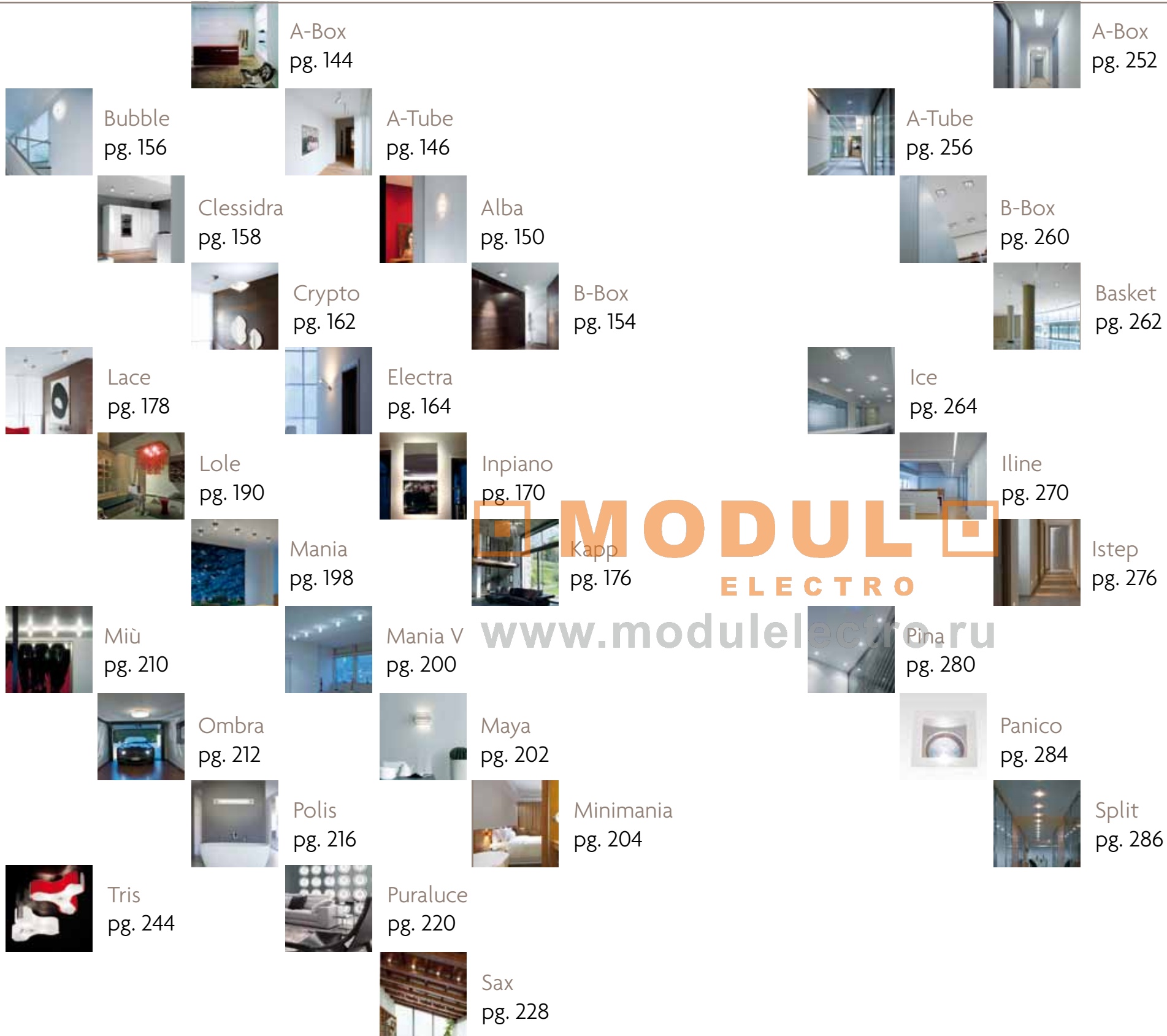

A-Box
pg. 144

Bubble
pg. 156

Clessidra
pg. 158

Crypto
pg. 162

Lace
pg. 178

Lole
pg. 190

Mania
pg. 198

Miù
pg. 210

Ombra
pg. 212

Polis
pg. 216

Tris
pg. 244

A-Tube
pg. 146

Alba
pg. 150

B-Box
pg. 154

Electra
pg. 164

Inpiano
pg. 170

Kapp
pg. 176

Mania V
pg. 200

Maya
pg. 202

Minimania
pg. 204

Puraluce
pg. 220

Sax
pg. 228

A-Box
pg. 252

A-Tube
pg. 256

B-Box
pg. 260

Basket
pg. 262

Ice
pg. 264

Iline
pg. 270

Istep
pg. 276

Pina
pg. 280

Panico
pg. 284

Split
pg. 286

MODULO
ELECTRO
www.modulelectro.ru



Blow
pg. 292



Bubble
pg. 294



Buonanotte
pg. 296

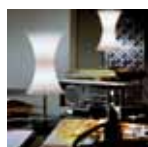

Clessidra
pg. 298



Edo
pg. 302



Curl my light
pg. 300



Giò
pg. 304



Laila
pg. 306



Magnetita
pg. 310

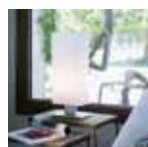

Mabel
pg. 308



Minimania
pg. 312



Puraluce
pg. 314



Soap
pg. 318



Trilogy
pg. 320



Andrei
pg. 326



Bubble
pg. 328

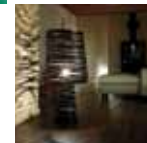

Curl my light
pg. 330



Escudo
pg. 334

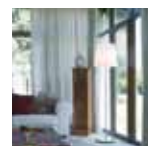

Laila
pg. 336

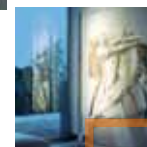

Laser
pg. 338



Menir
pg. 340

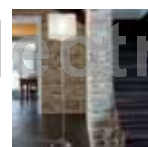

Trilogy
pg. 342

 **MODULO** 
ELECTRO

www.modulelectro.ru

Suspensions | Lampes à suspension | Hängeleuchten | Suspensiones

MODULO
ELECTRO
www.modulelectro.ru

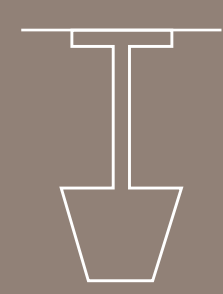

SOSPENSIONI

- Suspensions
- Lampes à suspension
- Hängeleuchten
- Suspensiones



MODULO
ELECTRO
www.modulelectro.ru

A-TUBE

DESIGN: ROCCO ESTE, 2008

A-TUBE SO

Project La Osteria Restaurant
Location Venice, Italy

Photographer Andrea Pancino







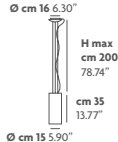
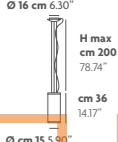

Lampada sospensione ad emissione di luce diretta e indiretta. Struttura in metallo bianco per articolo SO, in vetro bianco lucido con particolari cromati Per l'articolo SO1.

Suspended luminaire for direct and indirect lighting. White metal frame for the SO version, white polished glass and chrome accents for the SO1 version.

Lampe à suspension qui répand une clarté directe et indirecte. Structure en métal blanc pour la version SO, en verre blanc poli avec détails en chrome pour la version SO1.

Hängeleuchte mit direkter und indirekter Lichtverteilung. Die Metallstruktur ist bei der SO Version weiss lackiert, während bei der SO1 Version ist der Schirm aus weissem Opalglas. Mit verchromten metall teile.

Lámpara de suspensión para iluminación directa y indirecta. Estructura en metal blanco, difusor disponible en metal blanco en el art. SO o en vidrio blanco leche en el art. SO1. Con particulares en cromo.

nome name	A-Tube SO	A-Tube SO1
		
portalampana lamp socket	E27	E27
potenza max max wattage	2x75w	2x100w
simbolo symbol		
diffusore diffuser	—	016
montatura frame	Bk	Cr
certificazioni certifications		
IP	20	20
alimentatore gear	Non richiesto Not required	Non richiesto Not required
For USA and CANADA		
lamp socket	E26	E26
max wattage	2x100w	2x100w
symbol		
Fixture supplied with backplate	NO	NO
Mounts to standard 4" junction box	YES	YES
certifications		

 Ceiling lamp Pg. 146  Recessed Pg. 256



A-TUBE



MODUL
ELECTRO
www.modulelectro.ru

Lampada a sospensione ad emissione di luce diffusa. Struttura in metallo nickel satinato. Diffusore in vetro soffiato bianco satinato.

Suspended luminaire for diffuse lighting. Satin nickel metal frame. White satin hand blown glass diffuser.

Lampe à suspension qui répand une clarté diffuse. Structure en métal nickel-satiné. Diffuseur en verre soufflé blanc satiné.

Hängeleuchte mit gestreuter Lichtverteilung. Metallgestell aus satiniertem Nickel. Glasschirm aus satiniertem, weißem, mundgeblasenem Opalglas.

Lámpara de suspensión a emisión de luz difusa. Estructura en metal níquel satinado. Difusor en vidrio soplado blanco opalino satinado.

nome name	Alba SO
portalampada lamp socket	E27
potenza max max wattage	1x100w
simbolo symbol	
diffusore diffuser	030
montatura frame	Nt
certificazioni certifications	
IP	20
alimentatore gear	Non richiesto Not required
For USA and CANADA	
lamp socket	E26
max wattage	1x100w
symbol	
Fixture supplied with backplate	YES
Mounts to standard 4" junction box	YES
certifications	



Wall lamp

Pg. 150



Ceiling lamp

Pg. 150

MODULO
ELECTRO
www.modulelectro.ru



Lampada a sospensione ad emissione di luce diffusa. Struttura in metallo verniciato bianco. Diffusore in vetro soffiato disponibile in bianco lucido.

Suspended luminaire for diffuse lighting. White metal frame. Hand blown glass in white polished diffuser.

Lampe à suspension qui répand une clarté diffuse. Structure en métal blanc. Diffuseur en verre soufflé, disponible en blanc poli.

Hängeleuchte mit gestreuter Lichtverteilung. Metallgestell aus weiß. Glasschirm aus mundgeblasenem, weissem Opalglas.

Lámpara de suspensión a emisión de luz difusa. Estructura en blanco. Difusor en vidrio soplado blanco lustroso.



nome
name

Aloha SO2

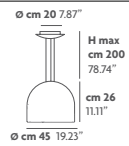

MODULO
ELECTRO
www.modulelectro.ru

portalampada lamp socket	E27
potenza max max wattage	1x100w
simbolo symbol	
diffusore diffuser	016
montatura frame	Bk
certificazioni certifications	
IP	20
alimentatore gear	Non richiesto Not required

**For USA
and CANADA**

lamp socket	E26
max wattage	1x100w
symbol	
Fixture supplied with backplate	NO
Mounts to standard 4" junction box	YES
certifications	
gear	Not required



Lampada a sospensione ad emissione di luce diffusa. Struttura e diffusore in metallo a sezioni coniche disponibile nei colori bianco (con cablaggio in tessuto nero) e nero (con cablaggio in tessuto bianco).

Suspended luminaire for diffuse lighting. Cone shaped sectional metal frame available in white (with black fabric cable) and black (with white fabric cable).

Suspension émettant une clarté diffuse. Structure en métal à sections coniques, disponible dans les couleurs blanc (avec le câble en tissu noir) et noir (avec le câble en tissu blanc).

Hängeleuchte mit gestreuter Lichtverteilung. Gestell und Schirm sind aus Metall mit kegelförmigen Abschnitten, verfügbar in den Farben Weiss (mit schwarze Stoffverkabelung) und Schwarz (mit weisse Stoffverkabelung).

Lámpara de suspensión a emisión de luz difusa. Estructura y difusor en metal a secciones cónicas disponible en color blanco (con cableado en tejido negro) o negro (con cableado en tejido blanco).

nome
name

Amourette SO

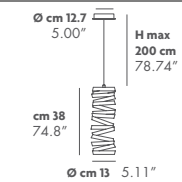

portalampada
lamp socket

E27

potenza max
max wattage

1X75w

simbolo
symbol



diffusore
diffuser

—

montatura
frame



certificazioni
certifications



IP

20

alimentatore
gear

Non richiesto
Not required

**For USA
and CANADA**

lamp socket

E26

max wattage

1X75w

symbol



Fixture
supplied with
backplate

NO

Mounts to
standard 4\"/>

YES

certifications



gear

Not required

Lampada a sospensione ad emissione di luce indiretta e diretta, struttura in metallo disponibile nei colori bianco o acciaio specchiato. Doppia accensione.

Suspended luminaire for indirect and direct lighting, frame available in white or in mirror metal finishing. Equipped with double switch.

Suspension émettant un éclairage indirect et direct structure en métal, disponible dans les couleurs: blanc ou acier miroir. Double allumage.

Hängeleuchte mit indirekter und direkter Lichtverteilung. Das Metallgestell kann weiss lackiert oder aus glänzendem Edelstahl sein. Doppelt einschaltbar.

Lámpara de suspensión para iluminación indirecta y directa. Estructura disponible en metal blanco o en acero inoxidable pulido. Equipada con doble interruptor.



nome name	Andrei SO
portalampada lamp socket	R7s 118mm + GU10 + E27
potenza max max wattage	1x200w + 2x50w + 1x75w
simbolo symbol	
diffusore diffuser	Al Bk
montatura frame	Bk
certificazioni certifications	0.5m CE V PC
IP	20
alimentatore gear	Non richiesto Not required
For USA and CANADA	
lamp socket	E26
max wattage	3x75w
symbol	
Fixture supplied with backplate	NO
Mounts to standard 4" junction box	YES
certifications	UL

MODULO ELECTRO
www.modulelectro.ru

Wall lamp Pg. 152 Floor lamp Pg. 326

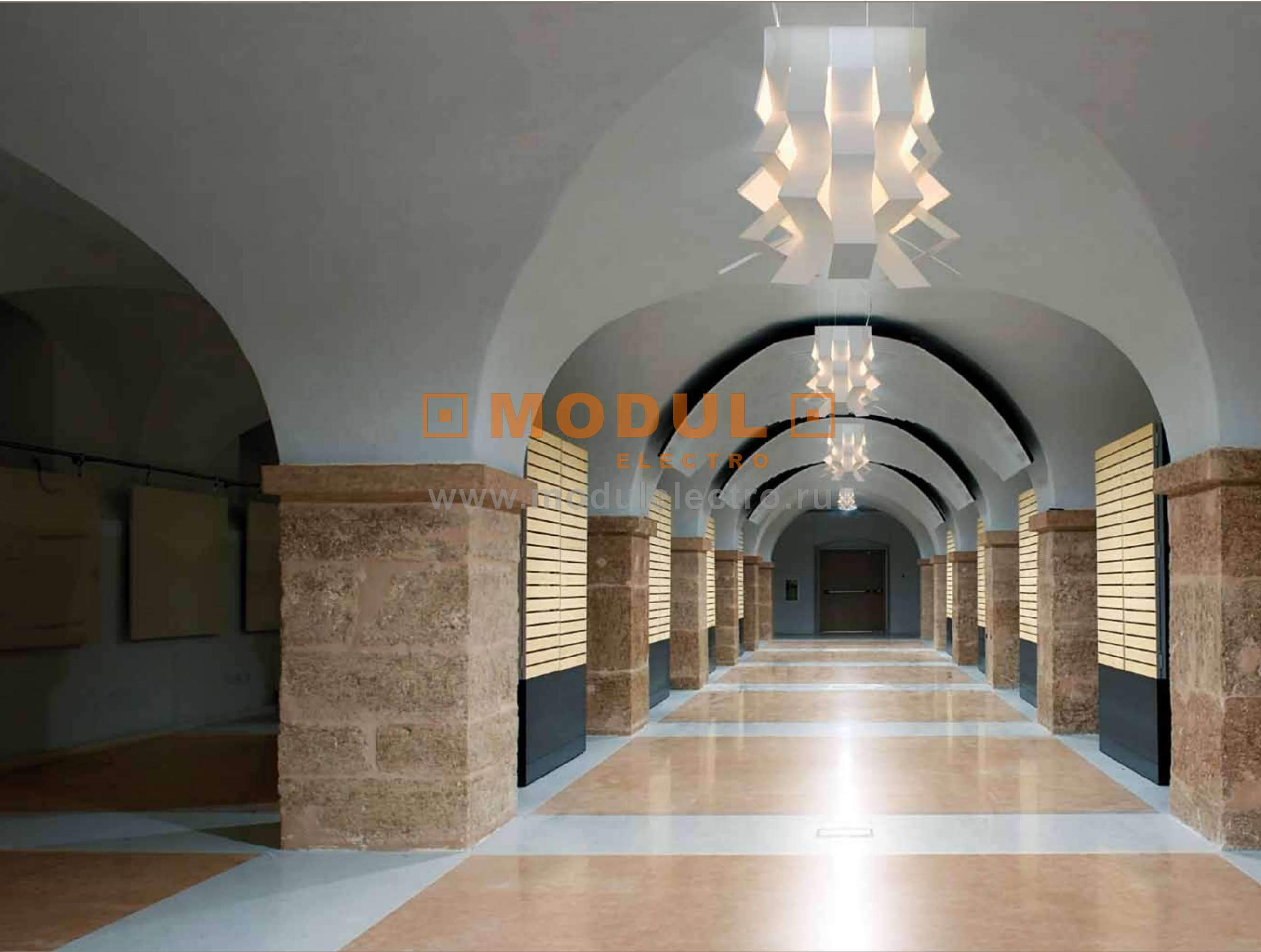

MODUL
ELECTRO
www.modulelectro.ru

BELL

DESIGN: ARCH. ALBERTO GHERARDI, 2000

BELL

Project Private Villa
Location Perugia, Italy

Lampada a sospensione ad emissione di luce diretta. Struttura in metallo microforata nickel satinato.

Suspended luminaire for direct lighting. Micro perforated satin nickel metal frame.

Lampe à suspension qui répand une clarté directe. Structure en métal micro-percé nickel satiné.

Hängeleuchte mit direkter Lichtverteilung. Gelochtes Metallgestell aus satiniertem Nickel.

Lámpara de suspensión a emisión de luz directa. Estructura en metal micro-agujerada níquel satinado.

nome name	Bell SO
portalampada lamp socket	E27
potenza max max wattage	1x100w
simbolo symbol	
diffusore diffuser	—
montatura frame	Nt
certificazioni certifications	
IP	20
alimentatore gear	Non richiesto Not required
For USA and CANADA	
lamp socket	E26
max wattage	1x100w
symbol	
Fixture supplied with backplate	NO
Mounts to standard 4\"/>	YES
certifications	

MODULO
ELECTRO
www.modulelectro.ru



BIG-MEC

DESIGN: S.I.D., 2005

BIG-MEC MAX

Project Le Méridien Hotel
Location New Delhi, India

Architect Bobby Mukherji & Ass.

Lampada a sospensione ad emissione di luce diffusa. Struttura in alluminio spazzolato. Diffusore in vetro bianco lucido. Su richiesta vetro disponibile nei colori giallo, blu, verde, rosso e specchio..

Suspended luminaire for diffuse lighting. Brushed aluminium frame. Polished white glass diffuser. Yellow, blue, green, red and mirror glass colours available upon request.

Lampe à suspension qui répand une clarté diffuse. Structure en aluminium brossé. Diffuseur en verre blanc poli. Sur demande, verre dans les couleurs jaune - verte - bleu - rouge et miroir.

Hängeleuchte mit gestreuter Lichtverteilung. Gestell aus gebürstetem Aluminium. Glasschirm aus weissem Kristallglas, auf Anfrage in den Farben Gelb, Blau, Grün, Rot oder aus Spiegelglas.

Lámpara de suspensión a emisión de luz difusa y indirecta. Estructura en aluminio cepillado. Difusor en vidrio cristal Blanco, bajo pedido en los colores amarillo, azul, verde, rojo o en vidrio espejado.











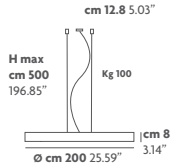
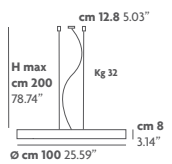
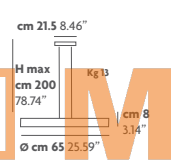

MODUL
ELECTRO
www.modulelectro.ru



BIG-MEC



MODULO
ELECTRO
www.modulelectro.ru

nome name	Big Mec MAX	Big Mec SO	Big Mec SO1
	 <p>cm 12.8 5.03" Kg 100 cm 8 3.14" Ø cm 200 25.59"</p>	 <p>cm 12.8 5.03" Kg 32 cm 8 3.14" Ø cm 100 25.59"</p>	 <p>cm 21.5 8.46" Kg 13 cm 8 3.14" Ø cm 65 25.59"</p>
portalampada lamp socket	2G11	2G10	2G10
potenza max max wattage	8x80w	Multi watt 8x36w or 8x24w or 8x18w	Multi watt 4x36w or 4x24w or 4x18w
simbolo symbol			
diffusore diffuser	038	038	038
montatura frame	As	As	As
certificazioni certifications	0,5 m CE V ES PC	0,3 m CE V ES PC	0,5 m CE V ES PC
IP	20	20	20
alimentatore gear	Elettronico dimmerabile incluso Elect. dimm. incl.	Elettronico incluso Elect. incl.	Elettronico incluso Elect. incl.
For USA and CANADA			
lamp socket	2G11	2G10	2G10
max wattage	8x55w	8x36w	4x36w
symbol			
Fixture supplied with backplate	NO	NO	NO
Mounts to standard 4" junction box	YES	YES	YES
certifications			
gear	Elect. incl.	Elect. incl.	Elect. incl.



MODUL
ELECTRO
www.modulelectro.ru

BUBBLE

DESIGN: S.I.D., 1950-1982

BUBBLE

Project Private villa
Location Treviso, Italy

Photographer Andrea Pancino



Lampada a sospensione ad emissione di luce diffusa. Struttura in metallo nickel satinato. Diffusore in vetro soffiato bianco satinato.

Suspended luminaire for diffuse lighting. Satin nickel metal frame. White satin hand blown glass diffuser.

Lampe à suspension qui répand une clarté diffuse. Structure en métal nickel-satiné. Diffuseur en verre soufflé blanc satiné.

Hängeleuchte mit gestreuter Lichtverteilung. Metallgestell aus satiniertem Nickel. Schirm aus weissem, satiniertem, mundgeblasenem Opalglas.

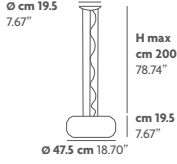
Lámpara de suspensión a emisión de luz difusa. Estructura en metal níquel satinado. Difusor en vidrio soplado blanco opalino, satinado.

nome name	Bubble SO
	
portalampada lamp socket	G9
potenza max max wattage	3x75w
simbolo symbol	
diffusore diffuser	030
montatura frame	Nt
certificazioni certifications	0.5m CE V PC
IP	20
alimentatore gear	Non richiesto Not required
For USA and CANADA	
lamp socket	E12
max wattage	3x40w
symbol	
Fixture supplied with backplate	YES
Mounts to standard 4" junction box	YES
certifications	—
gear	Not required



Ceiling lamp

Pg. 156



Table lamp

Pg. 294



Wall lamp

Pg. 156



Floor lamp

Pg. 328



MODULO
ELECTRO
www.modulelectro.ru

BUBBLE

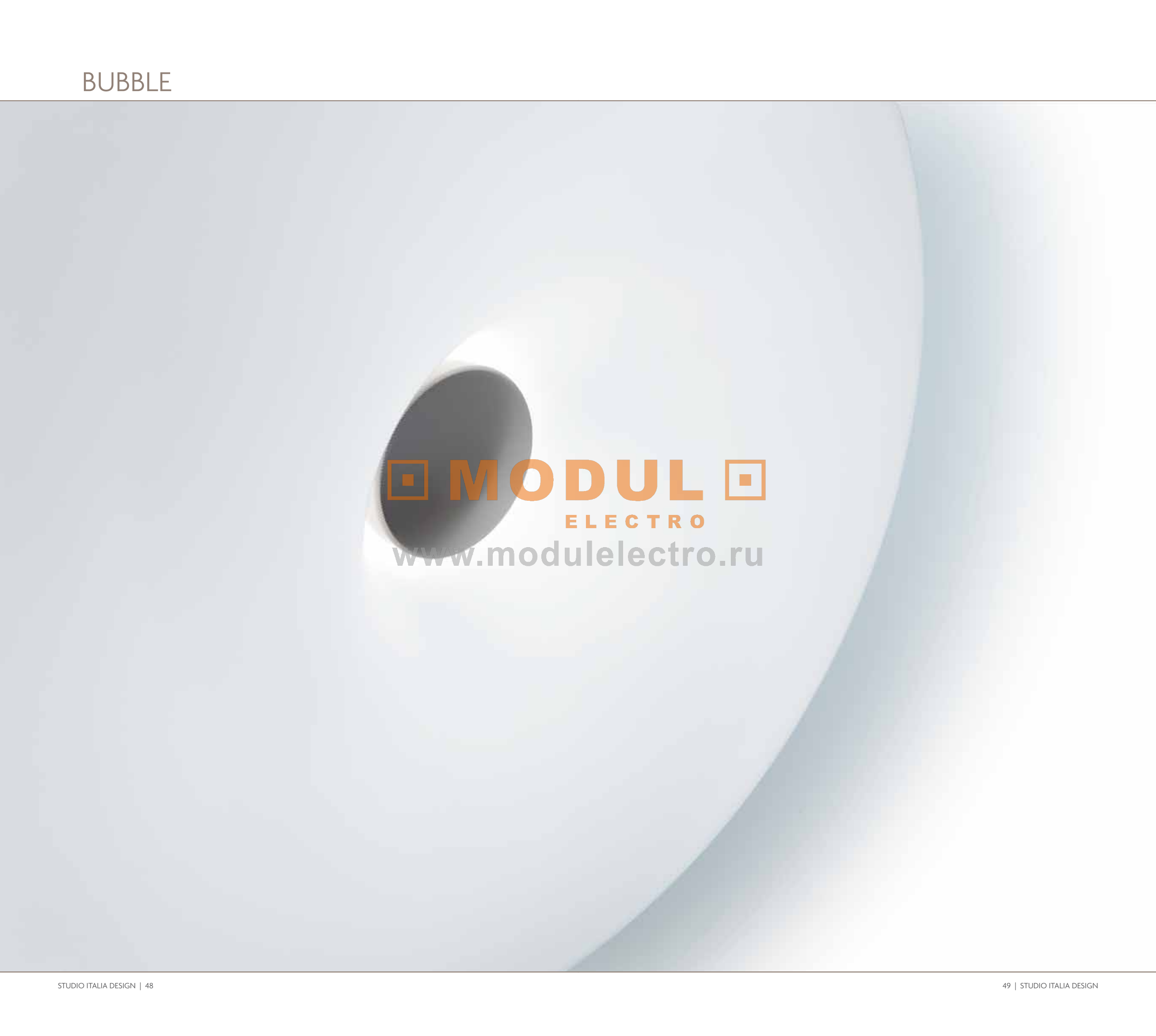

MODUL
ELECTRO
www.modulelectro.ru



Lampada a sospensione ad emissione di luce diffusa. Struttura in metallo nickel satinato. Diffusore in vetro soffiato "plisse" disponibile nei colori: bianco satinato, rosso lucido e ambra satinato.

Suspended luminaire for diffuse lighting. Satin nickel metal frame. Pleated hand blown glass diffuser, available in the following colours: white satin, red polished and amber polished.

Lampe à suspension qui répand une clarté diffuse. Structure en métal nickel satiné. Diffuseur en verre soufflé « plissé » disponible dans les couleurs: blanc satiné, rouge poli et ambre poli.

Hängeleuchte mit gestreuter Lichtverteilung. Metallgestell aus satiniertem Nickel. Schirm aus „plissiertem“, mundgeblasenem Glas, erhältlich in den Farben: Weiss, satinierten Amber oder Rot glänzend.

Lámpara de suspensión a emisión de luz difusa. Estructura en metal níquel satinado. Difusor en vidrio soplado opalino "plisado" disponible en los colores: blanco, ámbar satinado o rojo lustroso.

MODUL
ELECTRO
www.modulelectro.ru



CLESSIDRA

nome name	Clessidra SO	Clessidra SO1
	<p>Ø cm 16.630" H max cm 250 98.43" cm 45 17.72" Ø cm 19 cm 7.48"</p>	<p>Ø 12.8 cm 5.03" H max cm 200 78.74" cm 22 8.66" Ø cm 13.5 5.31"</p>
portalampada lamp socket	E27	G9
potenza max max wattage	2x150w	2x40w
simbolo symbol		
diffusore diffuser		
montatura frame	Nt	Nt
certificazioni certifications		
IP	20	20
alimentatore gear	Non richiesto Not required	Non richiesto Not required

For USA and CANADA		
lamp socket	E26	E12
max wattage	2x100w	2x40w
symbol		
Fixture supplied with backplate	YES	NO
Mounts to standard 4" junction box	YES	YES
certifications		
gear	Not required	Not required

MODUL
ELECTRO
www.modulelectro.ru



Ceiling lamp

Pg. 158



Table lamp

Pg. 298



Wall lamp

Pg. 158

CURL MY LIGHT

DESIGN: DIMA LOGINOFF, 2010

Lampada a sospensione ad emissione di luce diffusa. Struttura e diffusore in metallo a sezioni circolari disponibili nei colori bianco (con cablaggio in tessuto nero) e nero (con cablaggio in tessuto bianco).

Suspended luminaire for diffused lighting. Round sectional metal frame and diffuser, available in white (with black fabric cable) and black (with white fabric cable).

Suspension émettant une clarté diffuse. Structure et diffuseur en métal à sections circulaires, disponible dans les couleurs blanc (avec le câble en tissu noir) et noir (avec le câble en tissu blanc).

Hängeleuchte mit gestreuter Lichtverteilung. Gestell aus weiß (mit schwarze Stoffverkabelung)- oder schwarzlackiertem (mit weisse Stoffverkabelung) Metall.

Lámpara de suspensión a emisión de luz difusa. Estructura en metal a secciones circulares disponible en blanco (con cableado en tejido negro) o negro (con cableado en tejido blanco).



nome
name

Curl my light SO

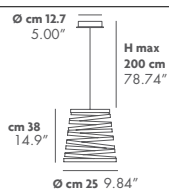

portalampada lamp socket	E27
potenza max max wattage	1X75w
simbolo symbol	
diffusore diffuser	-
montatura frame	<input type="checkbox"/> Bk <input type="checkbox"/> Nr
certificazioni certifications	
IP	20
alimentatore gear	Non richiesto Not required

**For USA
and CANADA**

lamp socket	E26
max wattage	1X75w
symbol	
Fixture supplied with backplate	NO
Mounts to standard 4" junction box	YES
certifications	
gear	Not required



Table lamp

Pg. 300



Floor lamp

Pg. 331

MODULO
ELECTRO
www.modulelectro.ru

CURL MY LIGHT

CURL MY LIGHT

Project Private Villa
Location Munich, Germany

Photographer Andrea Pancino



MODUL
ELECTRO
www.modulelectro.ru

Lampada a sospensione ad emissione di luce diffusa. Struttura in metallo nickel satinato, diffusore in vetro bianco satinato. Struttura con dimmer.

Suspended luminaire for diffused lighting. Satin nickel metal frame, white satin glass diffuser. Frame with dimmer.

Suspension qui répand une clarté diffuse. Structure en métal nickel satiné, diffuseur en verre blanc satiné. Avec variateur

Hängeleuchten mit gestreuter Lichtverteilung. Metallgestell aus satiniertem Nickel. Schirm aus weißem, satiniertem Glas. Eingebautes dimmer

Lámparas de suspensión para iluminación difusa. Estructura metálica en níquel satinado, difusor en vidrio blanc satinado.



nome
name

Flat SO2

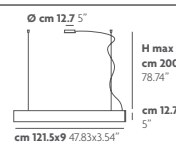

MODULO
ELECTRO

www.modulelectro.ru

portalampada lamp socket	G5
potenza max max wattage	1x54w
simbolo symbol	
diffusore diffuser	038
montatura frame	Nt
certificazioni certifications	
IP	20
alimentatore gear	Elettronico dimmerabile incluso Elect. dimm. incl.

For USA
and CANADA

lamp socket	Available only EU version
max wattage	Available only EU version
symbol	Available only EU version
Fixture supplied with backplate	Available only EU version
Mounts to standard 4" junction box	Available only EU version
gear	Available only EU version



Lampada a sospensione ad emissione di luce diffusa. Struttura in metallo verniciato con particolari in alluminio spazzolato. Diffusori superiore ed inferiore in vetro extra chiaro sabbiato, diffusori frontali in vetro bianco lucido o nero lucido.

Suspended luminaires for diffused lighting. Lacquered metal frame with brushed aluminium details. Upper and lower diffusers in sanded extra-clear glass, frontal diffusers in white polished and black polished glass.

Lampe à suspension qui répand une clarté diffuse. Structure en métal verni avec des détails en aluminium brossé. Diffuseurs supérieurs et inférieurs en verre extra claire sablé, diffuseurs frontales en verre blanc poli ou noir poli.

Hängeleuchte mit gestreuter Lichtverteilung. Gestell aus lackiertem Metall mit Metallteile aus gebürstetem Aluminium. Obere und untere Schirme sind aus sandgestrahltem extra-hellem Glas, die vordere glasschirme sind aus schwarzem Kristallglas oder aus weissem Kristallglas sein. Die vordere glasschirme sind.

nome name	Fly SO1
portalampada lamp socket	Kg 14 G5
potenza max max wattage	2x54w
simbolo symbol	
diffusore diffuser	027 038
montatura frame	As
certificazioni certifications	0.5m CE ENEC ES PC
IP	20
alimentatore gear	Elettronico incluso Elect. incl.
For USA and CANADA	
lamp socket	G5
max wattage	2x54w
symbol	
Fixture supplied with backplate	NO
Mounts to standard 4\"/>	
certifications	UL
gear	Elect. incl.



Wall lamp

Pg. 166

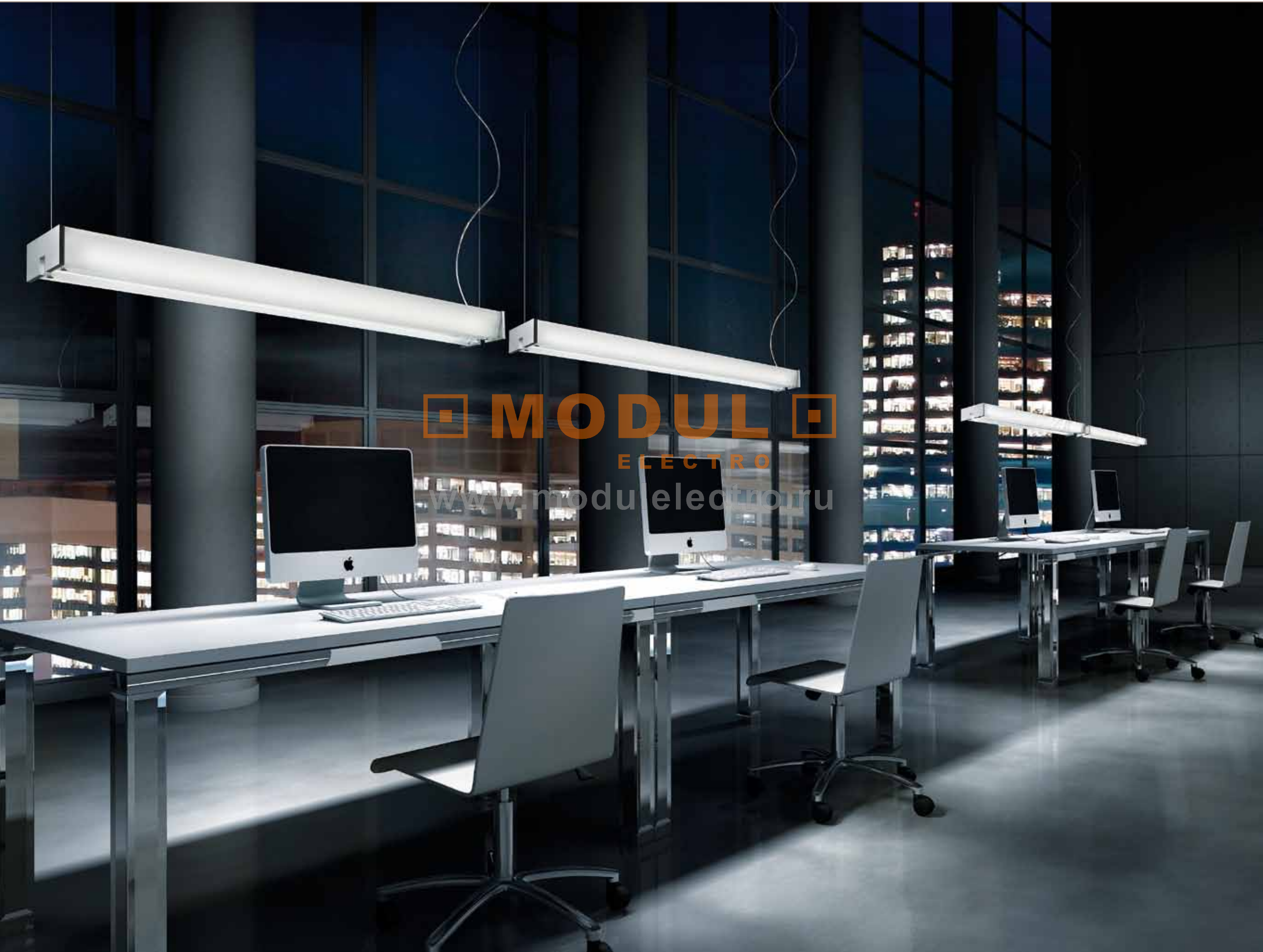

MODUL
ELECTRO
www.modulelectro.ru

Lampada a sospensione ad emissione di luce diretta ed indiretta diffusa. Struttura in metallo verniciato con particolari in alluminio spazzolato. E' dotato di una centralina elettronica (DALI) ed un comando remoto a raggi infrarossi per controllare la luminosità dei tubi fluorescenti RGB posizionati nella parte superiore ed inferiore della struttura. Diffusori superiori ed inferiori in vetro extra chiaro sabbiato, diffusori frontali in vetro nero.

Suspended luminaire for direct and indirect diffused lighting. Lacquered metal frame with brushed aluminium details. Equipped with an electronic control unit (DALI) with infrared remote control to adjust the upper RGB fluorescent tubes and the lower white fluorescent ones. Upper and lower diffusers in sanded extra clear crystal, frontal diffusers in black glass.

Lampe à suspension qui répand une clarté directe et indirecte diffuse. Structure en métal verni avec des détails en aluminium brossé. L'article est équipé d'une central électronique (DALI) et un télécommande à infrarouge pour contrôler la luminosité des tubes fluorescents RGB placés dans la partie supérieure et des tubes fluorescents blancs dans la partie inférieure. Diffuseurs supérieurs et inférieurs en verre extra-claire sablé, diffuseurs frontales en verre noir.

Hängeleuchte mit direkter und indirekter Lichtverteilung. Gestell aus lackiertem Metall mit Metallteile aus gebürstetem Aluminium. Die Leuchte ist mit einer elektronischen Steuerung (DALI) und einer Fernbedienung mit Infrarotstrahlen, die die Helligkeit der untere und obere RGB Leuchtstoffröhre steuern ausgestattet. Obere und untere Schirme sind aus sandgestrahltem extra-hellem Glas die vordere Glasschirme sind aus schwarzem Kristallglas.

Lámpara de suspensión a emisión de luz directa en indirecta. Estructura en metal barnizado con particulares en aluminio cepillado. Es dotado de una centralina electrónica (DALI) y de un mando remoto a rayos infrarrojos para controlar la luminosidad de los tubos fluorescentes RGB colocados en la parte superior e inferior de la estructura. Difusores superiores e inferiores en vidrio extra claro arenado, difusores frontales en vidrio negro.

MODULO
ELECTRO
www.modulelectro.ru



FLY RGB



nome
name

Fly SO

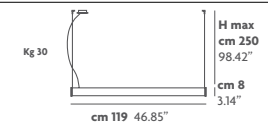

portalampada
lamp socket

G5

potenza max
max wattage

2x80w + 3x80w RGB

simbolo
symbol



diffusore
diffuser

027

montatura
frame

As

certificazioni
certifications



IP

20

alimentatore
gear

DALI incluso
DALI incl.

For USA and CANADA
MODULO ELECTRO

www.modulelectro.ru

lamp socket

Available only in EU version

max wattage

Available only in EU version

symbol

Available only in EU version

Fixture
supplied with
backplate

Available only in EU version

Mounts to
standard 4"
junction box

Available only in EU version

gear

Available only in EU version

Lampada a sospensione ad emissione di luce diffusa. Struttura in metallo cromato. Diffusori in cristallo soffiato e lavorato a mano.

Suspended luminaire for diffused lighting. Chromed metal frame. Hand – blown glass diffusers, hand formed by Murano Masters.

Lampe à suspension qui répand une clarté diffuse. Structure en métal chromé. Diffuseur en verre soufflé travaillé à la main par les Maîtres Muranesi.

Hängeleuchte mit gestreuter Lichtverteilung. Gestell aus verchromtem Metall. Glasschirm aus handbearbeitetem und von den Murano Meistern mundgeblasenem Kristallglas.

Lámpara de suspensión a emisión de luz difusa. Estructura en metal cromado. Difusor en cristal soplado y hecho a mano por Maestros de Murano.



MODUL
ELECTRO
www.modulelectro.ru



nome name	Kapp SO2
portalampada lamp socket	G9
potenza max max wattage	18x40 w
simbolo symbol	
diffusore diffuser	000
montatura frame	Cr
certificazioni certifications	0,5 m
IP	20
alimentatore gear	Non richiesto Not required

For USA and CANADA	
lamp socket	E12
max wattage	18x20w
symbol	
Fixture supplied with backplate	NO
Mounts to standard 4\"/>	YES
certifications	
gear	Not required



MODULO
ELECTRO
www.modulelectro.ru



Wall lamp

Pg. 174



Ceiling lamp

Pg. 176





Lampada a sospensione ad emissione di luce diretta. Struttura in metallo cromato. Diffusore disponibile in cristallo o vetro bianco lucido con applicazioni di cristallo lavorato a mano.

Suspended luminaire for direct lighting. Chromed metal frame. Diffuser, with crystal hand – made details, available in crystal and white polished glass.

Lampe à suspension qui répand une clarté directe. Structure en métal chromé. Diffuseur en cristal transparent ou en verre blanc poli avec des applications en verre travaillé à la main.

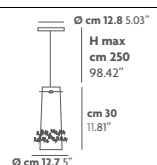
Hängeleuchte mit direkter Lichtverteilung. Gestell aus verchromtem Metall. Glasschirm aus durchsichtigem oder weissem Kristall mit handgemachten Verzierungen der Meistern aus Murano.

Lámpara de suspensión a emisión de luz directa. Estructura en metal cromado. Difusor en cristal transparente o blanco con aplicaciones de cristal hecho a mano por Maestros de Murano.

nome name	Lace SO
	
portlampada lamp socket	E14
potenza max max wattage	1x40w
simbolo symbol	
diffusore diffuser	000 016
montatura frame	Cr
certificazioni certifications	
IP	20
alimentatore gear	Non richiesto Not required
For USA and CANADA	
lamp socket	E12
max wattage	1x40w
symbol	
Fixture supplied with backplate	NO
Mounts to standard 4" junction box	YES
certifications	
gear	Not required

 Ceiling lamp
Pg. 178

MODUL
ELECTRO
www.modulelectro.ru









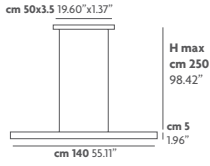
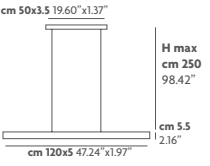

Lampada a sospensione ad emissione di luce diretta. Struttura in alluminio spazzolato. Diffusori in vetro extra chiaro sabbiato.

Suspended luminaire for direct lighting. Brushed aluminium frame. Sanded extra clear glass diffusers.

Lampe à suspension qui répand une clarté directe. Structure en aluminium brossé. Diffuseur en verre extra clair sablé.

Hängeleuchte mit direkter Lichtverteilung. Gestell aus gebürstetem Aluminium. Schirm aus sandgestrahltem Glas.

Lámpara de suspensión a emisión de luz difusa. Estructura en aluminio cepillado. Difusor en vidrio arenado.

nome name	Lasero SO1	Lasero SO2
		
portalampana lamp socket	G9	G5
potenza max max wattage	8x40w	1x54w
simbolo symbol		
diffusore diffuser	038	038
montatura frame	As	As
certificazioni certifications		
IP	20	20
alimentatore gear	Non richiesto Not required	Elettronico incluso Elect. incl.
For USA and CANADA		
lamp socket	G9	G5
max wattage	8x40w	1x54w
symbol		
Fixture supplied with backplate	YES	YES
Mounts to standard 4" junction box	YES	YES
certifications	—	
gear	Not required	Elect. incl.



 Wall lamp Pg. 184  Floor lamp pg. 338

Lampada modulare a sospensione ad emissione di luce diffusa. Struttura in metallo cromato con diffusori in vetro soffiato e lavorato a mano disponibili nei colori cristallo, cristallo incamiciato bianco, cristallo incamiciato rosso e cristallo incamiciato nero. Modelli che si prestano a realizzazioni personalizzate.

Modular suspended luminaire for diffused lighting. Chrome metal frame with hand blown and worked glass, available in crystal, white-crystal, red-crystal and black-crystal. These models lend themselves to a wide range of custom solutions.

Suspension modulaire émettant une clarté diffuse. Structure en métal chromé avec diffuseurs en verre soufflé et travaillé à la main, disponible dans les couleurs Crystal, Crystal – blanc et Crystal – rouge, nuare et crystal. Modèles qui se prêtent à réalisations personnalisées.

Hängeleuchte mit gestreuter Lichtverteilung. Verchromter Metallgestell. Schirme aus handbearbeitetem und mundgeblasenem Kristallglas, verfügbar in den Farben weiss, rot, schwarz oder durchsichtig. Bietet mehrere individuelle Gestaltungsmöglichkeiten.

Lámpara de suspensión a iluminación difusa. Estructura en metal cromado con difusores en vidrio soplado hecho a mano disponibles en cristal, cristal blanco, negro o rojo. Estos modelos se pueden personalizar.

MODULO
ELECTRO
www.modulelectro.ru

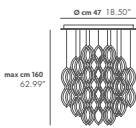
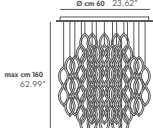
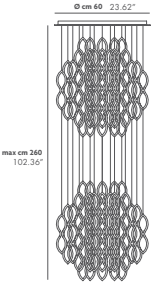
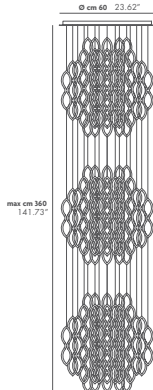

LOLE

nome name	Lole SO	Lole SO1	Lole SO2	Lole SO3
				
portalampada lamp socket	E27	E27	E27	E27
potenza max max wattage	1x100w	1x100w	2x100w	3x100w
simbolo symbol				
diffusore diffuser	000 016 027 010	000 016 027 010	000 016 027 010	000 016 027 010
montatura frame	Cr	Cr	Cr	Cr
certificazioni certifications				
IP	20	20	20	20
alimentatore gear	Non richiesto Not required	Non richiesto Not required	Non richiesto Not required	Non richiesto Not required
For USA and CANADA				
lamp socket	E26	E26	E26	E26
max wattage	1x100w	1x100w	2x100w	3x100w
symbol				
Fixture supplied with backplate	NO	NO	NO	NO
Mounts to standard 4\" junction box	YES	YES	YES	YES
certifications				
gear	Not required	Not required	Not required	Not required



 Ceiling lamp Pg. 190  Wall lamp Pg. 190



MODUL
ELECTRO
www.modulelectro.ru

Lampada a sospensione ad emissione di luce diretta. Struttura in metallo microforata disponibile nelle varianti nickel satinato o cromato.

Suspended luminaire for direct lighting. Micro perforated metal frame available in satin nickel or chrome.

Lampe à suspension qui répand une clarté directe. Structure en métal micro-percé disponible dans les finitions nickel satiné ou chromé.

Hängeleuchte mit direkter Lichtverteilung. Gelochtes Metallgestell aus satiniertem Nickel oder verchromt.

Lámpara de suspensión a emisión de luz directa. Estructura en metal micro-agujerada disponible en las variantes níquel satinado o cromada.

nome name	Mania SO1
portalampada lamp socket	GU10
potenza max max wattage	1x50w
simbolo symbol	
diffusore diffuser	—
montatura frame	Cr Nt
certificazioni certifications	
IP	20
alimentatore gear	Non richiesto Not required
For USA and CANADA	
lamp socket	E12
max wattage	1x40w
symbol	
Fixture supplied with backplate	NO
Mounts to standard 4" junction box	YES
certifications	
gear	Not required

Ceiling lamp

Pg. 198



MODULO
ELECTRO
www.modulelectro.ru



Lampada a sospensione ad emissione di luce diretta e diffusa. Struttura in metallo nickel satinato. Diffusore in vetro soffiato lucido inciso a mano disponibile nei colori bianco e marrone.

Suspended luminaire for direct and diffused lighting. Satin-nickel metal frame. Hand engraved blown glass diffuser available in white and brown.

Lampe à suspension qui répand une clarté directe et diffuse. Structure en métal nickel satiné. Diffuseur en verre soufflé et gravé à la main disponible dans les couleurs blanc et marron.

Hängeleuchte mit direkter und gestreuter Lichtverteilung. Metallgestell aus satiniertem Nickel. Mundgeblasener und handgeschliffener Glasschirm aus weiß oder braun glänzendem Opalglas.

Lámpara de suspensión a emisión de luz directa y difusa. Estructura en metal níquel satinado. Difusor en vidrio soplado y entallado a mano blanco o marron brillante.

nome
name

Mania V SO1

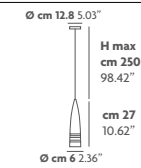

portalampana
lamp socket

E14

potenza max
max wattage

1x40w

simbolo
symbol
diffusore
diffuser



016 047

montatura
frame

Nt

certificazioni
certifications



IP

20

alimentatore
gear

Non richiesto
Not required

For USA
and CANADA

lamp socket

E12

max wattage

1x40w

symbol



Fixture
supplied with
backplate

NO

Mounts to
standard 4"
junction box

YES

certifications



gear

not required



Ceiling lamp

Pg. 198

Lampada sospensione ad emissione di luce diffusa. Struttura in metallo verniciato bianco con particolari cromati.

Suspended luminaire for diffused lighting. White lacquered metal frame with chrome accents.

Lampe à suspension qui répand une clarté diffuse. Structure en métal verni blanc avec détails en chrome.

Hängeleuchte mit gestreuter Lichtverteilung. Die Metallstruktur ist weiss lackiert mit verchromten Metallteile.

Lámpara de suspensión fluorescente de luz difusa con estructura de metal lacado blanco con particulares en cromo.

nome
name

Maya SO

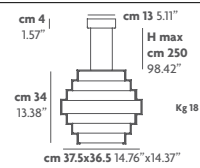

portalampada lamp socket	GX24q-3
potenza max max wattage	4x26w
simbolo symbol	
diffusore diffuser	—
montatura frame	Bk
certificazioni certifications	
IP	20
alimentatore gear	Elettronico incluso Elect. incl.

For USA
and CANADA

lamp socket	GX24q-3
max wattage	4x26w
symbol	
Fixture supplied with backplate	NO
Mounts to standard 4\"/>	
certifications	
gear	Elect. incl.



Wall lamp

Pg. 202



Ceiling lamp

Pg. 202



MODULO
ELECTRO
www.modulelectro.ru

Lampada a sospensione ad emissione di luce diffusa. Struttura interna in metallo verniciato bianco. E' equipaggiata di un motore che, collegato a dei sostegni portanti permette al diffusore in soffice tessuto ignifugo di fluttuare. Doppia accensione.

Suspended luminaire for diffused lighting. Inner white lacquered metal frame equipped with a motor connected to supporting arms enabling the fireproof cloud like diffuser to rise and fall. Double Switch .

Lampe à suspension qui répand une clarté diffuse. La structure interne en métal verni blanc est équipée d'un moteur relié à des bras de soutien, qui permet au diffuseur en souple tissu ignifuge de fluctuer. Double allumage.

Hängeleuchte mit gestreuter Lichtverteilung. Das innere Metallgestell ist weiss lackiert und mit einem Motor ausgestattet, der durch einige Metallarme das weiche und feuerhemmende Gewebe zum schweben bringt. Zweifach schaltbar.

Lámpara de suspensión para iluminación difusa. Estructura interior en metal barnizado blanco y equipada de un motor que, unido a los sostenes portante permite al difusor en blando tejido ignífugo de flotar. Doble encendido



nome name	Nuvola SO1	Nuvola SO2
portalampada lamp socket	E27	E27
potenza max max wattage	8x30w CFL Only	4x30w CFL Only
simbolo symbol		
diffusore diffuser		
montatura frame	Cr	Cr
certificazioni certifications		
IP	20	20
alimentatore gear	Non richiesto Not required	Non richiesto Not required
For USA and CANADA		
lamp socket	E26	E26
max wattage	8X24w CFL Only	4x24w CFL Only
symbol		
Fixture supplied with backplate	NO	NO
Mounts to standard 4\"/>	YES	YES
certifications	—	—
gear	Not required	Not required



MODULO
ELECTRO
www.modulelectro.ru



MODULO
ELECTRO
www.moduloelectro.ru

Lampada a sospensione ad emissione di luce diffusa. Struttura in nickel spazzolato. Diffusore in cristallo extra chiaro sabbato.

Suspended luminaire for diffused lighting. Brushed nickel metal frame. Extra clear sanded crystal diffuser.

Lampe à suspension qui répand une clarté diffuse. Structure en métal nickel brossé. Diffuseur en verre extra-claire sablé.

Hängeleuchte mit gerstreuter Lichtverteilung. Metallgestell aus gebürstetem Nickel. Schirm aus extra-hellem Kristallglas.

Lámpara de suspensión a emisión de luz difusa. Estructura en metal disponible en níquel cepillado. Difusor en vidrio cristal extra claro.



MODULO ELECTRO
www.modulelectro.ru

nome name	Ovi SO	Ovi SO1
portalampada lamp socket	R7s 118mm	R7s 118mm
potenza max max wattage	1x300w	1x300w
simbolo symbol		
diffusore diffuser	038	038
montatura frame	Ns	Ns
certificazioni certifications	0.5m CE V PG	0.5m CE V PG
IP	20	20
alimentatore gear	Non richiesto Not required	Non richiesto Not required
For USA and CANADA		
lamp socket	R7s long	R7s long
max wattage	1x300w	1x300w
symbol		
Fixture supplied with backplate	NO	NO
Mounts to standard 4" junction box	YES	YES

Lampada a sospensione ad emissione di luce diffusa. Struttura in metallo nickel satinato. Diffusore in vetro soffiato bianco satinato.

Suspended luminaire for diffused lighting. Satin nickel metal frame. White satin hand blown glass diffuser.

Lampe à suspension qui répand une clarté diffuse. Structure en métal nickel-satiné. Diffuseur en verre blanc soufflé.

Hängeleuchte mit gestreuter Lichtverteilung. Gestell aus satiniertem Nickel. Glasschirm aus satiniertem, weißem, mundgeblasenem Opalglas.

Lámpara de suspensión a emisión de luz difusa. Estructura en metal níquel satinado. Difusor en vidrio soplado blanco opalino satinado.



nome name	Playa SO
portalampada lamp socket	E27
potenza max max wattage	1x100w
simbolo symbol	
diffusore diffuser	030
montatura frame	Ns
certificazioni certifications	
IP	20
alimentatore gear	Non richiesto Not required
For USA and CANADA	
lamp socket	E26
max wattage	1x100w
symbol	
Fixture supplied with backplate	NO
Mounts to standard 4" junction box	YES
certifications	
gear	Not required

MODULO
ELECTRO
www.modulelectro.ru





Lampada a sospensione ad emissione di luce diffusa. Struttura in metallo nickel satinato. Diffusore in metacrilato trasparente.

Suspended luminaire for diffused lighting. Satin nickel metal frame. Transparent acrylic diffuser.

Lampe à suspension qui répand une clarté diffuse. Structure en métal nickel satiné. Diffuseur en méthacrylate transparent.



Hängeleuchte mit direkter Lichtverteilung. Metallgestell aus satiniertem Nickel. Schirm aus durchsichtigem Methacrylat.

Lámpara de suspensión a emisión de luz directa. Estructura en metal níquel satinado. Difusor en metacrilato transparente.

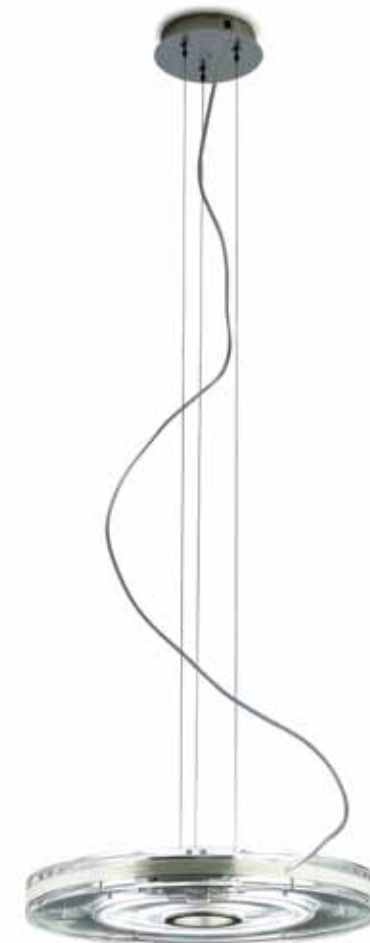
 **MODUL** 
ELECTRO
www.modulelectro.ru

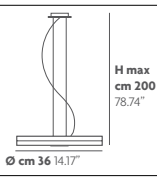

PURALUCE

nome name	Puraluce SO
	
portalampana lamp socket	2Gx13
potenza max max wattage	1x22w
simbolo symbol	
diffusore diffuser	000
montatura frame	Nt
certificazioni certifications	
IP	40
alimentatore gear	Elettronico incluso Elect. incl.

For USA and CANADA	
lamp socket	2Gx13
max wattage	1x22w
symbol	
Fixture supplied with backplate	NO
Mounts to standard 4" junction box	YES
certification	-
gear	Elect. incl.



MODULO
ELECTRO
www.modulelectro.ru



Wall lamp
Pg. 222



Ceiling lamp
Pg. 222



Table lamp
Pg. 314

Lampada a sospensione ad emissione di luce diffusa. Struttura in nickel spazzolato. Diffusore in cristallo extra chiaro sabbato.

Suspended luminaire for diffused lighting. Brushed nickel metal frame. Extra clear sanded crystal diffuser.

Lampe à suspension qui répand une clarté diffuse. Structure en métal nickel brossé. Diffuseur en verre extra-claire sablé.

Hängeleuchte mit gestreuter Lichtverteilung. Metallgestell aus gebürsteten Nickel. Schirm aus extra-hellem Kristallglas.

Lámpara de suspensión a emisión de luz difusa. Estructura en metal disponible en níquel cepillado. Difusor en vidrio cristal extra claro.

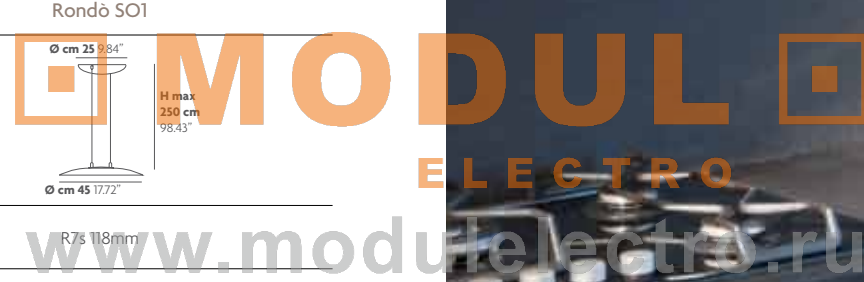

nome name	Rondò SO	Rondò SO1
portalampada lamp socket	R7s 118mm	R7s 118mm
potenza max max wattage	1x300w	1x300w
simbolo symbol		
diffusore diffuser	038	038
montatura frame	Ns	Ns
certificazioni certifications		
IP	20	20
alimentatore gear	Non richiesto Not required	Non richiesto Not required
For USA and CANADA		
lamp socket	R7s long	R7s long
max wattage	1x300w	1x300w
symbol		
Fixture supplied with backplate	NO	NO
Mounts to standard 4" junction box	YES	YES

Lampada a sospensione ad emissione di luce diffusa. Struttura in alluminio spazzolato. Diffusore in vetro soffiato trasparente. Nella versione Soap MAX diffusore parzialmente satinato.

Suspended luminaire for diffused lighting. Brushed aluminium frame. Hand blown transparent glass diffuser. Partially etched diffuser in the Soap Max version.

Lampe à suspension qui répand une clarté diffuse. Structure en aluminium brossé. Diffuseur en verre transparent soufflé. Dans la version Soap Max le diffuseur est partiellement sablé.

Hängeleuchte mit gestreuter Lichtverteilung. Gestell aus gebuerstetem Aluminium. Schirm aus durchsichtigem mundgeblasenem Pyrexglas. Bei der Soap Max ist der Diffuser teilweise satiniert.

Lámpara de suspensión a emisión de luz difusa. Estructura en aluminio. Difusor en vidrio pyrex transparente soplado. En art. Soap Max: difusor parcialmente arenado.



MODUL
ELECTRO
www.modulelectro.ru



SOAP

SOAP MAX

Project Milan Spa
Location Milan, Italy

Architect. Paola Gerosa
Photographer Andrea Pancino

nome name	Soap MAX	Soap SO
portalampana lamp socket	2G11	G9
potenza max max wattage	1x55w	1x75w
simbolo symbol		
diffusore diffuser	000	000
montatura frame	As	As
certificazioni certifications		
IP	20	20
alimentatore gear	Elettronico incluso Elect. incl.	Non richiesto Not required

For USA
and CANADA

lamp socket	2G11	G9
max wattage	1x55w	1x75w
symbol		
Fixture supplied with backplate	NO	NO
Mounts to standard 4" junction box	YES	YES
certifications		—
gear	Elect. incl.	Not required



MODUL
ELECTRO
www.modulelectro.ru



Table lamp

Pg. 318





Lampada a sospensione ad emissione di luce diretta e diffusa. Struttura in metallo nickel satinato. Diffusore in vetro disponibile nei colori bianco satinato, rosso lucido e nero lucido. Sulla lampada con il vetro nero consigliamo l'utilizzo della lampadina Osram decopin.

Suspended luminaire for direct and diffused lighting. Satin-nickel metal frame. Glass diffuser available in: white satin, polished red and polished black. In the black glass version we suggest the use of the Osram decopin bulb.

Lampe à suspension qui répand une clarté directe et diffuse. Structure en métal nickel-satiné. Diffuseur en verre disponible dans les couleurs blanc satiné - rouge poli et noir poli. Pour le model avec le verre noir nous conseillons d'utiliser la lampe Osram decopin.











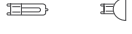







Hängeleuchte mit gestreuter und direkter Lichtverteilung. Gestell aus satiniertem Nickel. Glasschirm aus weißem, rotem oder schwarzem Glas. Bei der Leuchte mit dem schwarzem Glas wird als Leuchtmittel der Osram decopin G9 empfohlen.

Lámpara de suspensión a emisión de luz directa y difusa. Estructura en metal níquel cepillado. Difusor en vidrio disponible en los colores blanco satinado, rojo o negro. Con el vidrio negro aconsejamos el uso de las bombillas: Osram decopin G9.



 **MODUL** 
ELECTRO
www.modulelectro.ru



SURF

nome name	Surf SO2	Surf SO3
portalampada lamp socket	G9	G9
potenza max max wattage	10x40w	6x40w
simbolo symbol		
diffusore diffuser	  	  
montatura frame	Nt	Nt
certificazioni certifications	    	    
IP	20	20
alimentatore gear	Non richiesto Not required	Non richiesto Not required

For USA
and CANADA

lamp socket	G5	G9
max wattage	2x54w	6x40w
symbol		
Fixture supplied with backplate	NO	NO
Mounts to standard 4" junction box	YES	YES
certifications		—
gear	Elect. incl.	Not required

MODUL
ELECTRO
www.modulelectro.ru



Lampada a sospensione ad emissione di luce diretta. La struttura esterna è in metallo nero “soft touch” con particolare cromato. Il diffusore interno è disponibile in 4 finiture: bianco, giallo, verde e fucsia.

Suspended luminaire for direct lighting. Black “soft touch” metal outer frame with chrome accent. Available in 4 different inner finishings: white, yellow, green and fuchsia.

Suspension émettant une clarté directe. La structure extérieur est en métal noir « soft touch » avec détail en chrome. Est disponible en 4 différents finitions internes : blanc, jaune, vert et fuchsia.

Hängeleuchte mit direkter Lichtverteilung. Metallschirm, aussen schwarzlackiert „soft touch“ mit verchromten Teile. Innen weiss, gelb, fuchsinrot oder grün lackiert.

Lámpara de suspensión para iluminación directa. Estructura externa en metal negro “soft touch” con particolare en cromo. Difusor interior disponible pintado blanco, amarillo, verde o fucsia.

nome
name

Trunk SO

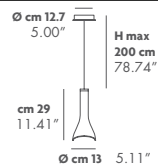



MODULO
ELECTRO

www.modulelectro.ru



portalampana lamp socket	E27
potenza max max wattage	1x75w
simbolo symbol	
diffusore diffuser	—
montatura frame	<input type="checkbox"/> NO <input type="checkbox"/> Bk <input type="checkbox"/> NO <input type="checkbox"/> Ye <input type="checkbox"/> NO <input type="checkbox"/> Fu <input type="checkbox"/> NO <input type="checkbox"/> Ag
certificazioni certifications	
IP	20
alimentatore gear	Non richiesto Not required
For USA and CANADA	
lamp socket	E26
max wattage	1x75w
symbol	
Fixture supplied with backplate	NO
Mounts to standard 4" junction box	YES
certifications	
gear	Not required



 **MODUL** 
ELECTRO
www.modulelectro.ru

Lampada sospensione ad emissione di luce diffusa. Struttura in metallo cromato. Diffusore in vetro soffiato bianco satinato.

Suspended luminaire for diffused lighting. Chromed metal frame. White satin hand blown glass diffuser.

Lampe à suspension qui répand une clarté diffuse. Structure en métal chromé. Diffuseur en verre soufflé blanc.

Hängeleuchte mit gestreuter Lichtverteilung. Gestell aus verchromtem Metall mit Metallteilen aus gebürstetem Aluminium. Glasschirm aus weißem, satiniertem, mundgeblasenem Glas.

Lámpara de suspensión a emisión de luz difusa. Estructura en metal cromado con particulares en aluminio cepillado. Difusor en vidrio soplado blanco satinado.

nome
name

Trilogy SO

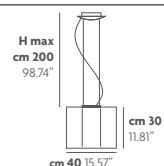

portalampada lamp socket	E27
potenza max max wattage	1x100w
simbolo symbol	
diffusore diffuser	030
montatura frame	Cr
certificazioni certifications	0.5m CE V PC
IP	20
alimentatore gear	Non richiesto Not required

For USA
and CANADA

lamp socket	E26
max wattage	1X100w
symbol	
Fixture supplied with backplate	NO
Mounts to standard 4" junction box	YES
certifications	UL
gear	Not required



Table lamp

Pg. 320



Floor lamp



Pg. 342



MODULO
ELECTRO
www.modulelectro.ru

TRILOGY



 **MODUL** 
ELECTRO
www.modulelectro.ru

Lampada a sospensione ad emissione di luce diffusa. Struttura in metallo cromato. Diffusore superiore ed inferiore in vetro bianco lucido. I diffusori laterali sono disponibili in vetro sagomato bianco lucido per versione SO. Per le versioni SO1 e SO2 i diffusori laterali sono disponibili in vetro bianco lucido, nero lucido, rosso lucido e metallo specchiato.

Suspended luminaire for diffused lighting. Chrome metal frame. Upper and lower diffusers in polished white glass. Side diffusers are available in polished white shaped glass for the SO version. For the SO1 and SO2 versions, the side diffusers are available in polished white, polished black, polished red and mirror finish metal.

Lampe à suspension qui répand une clarté diffuse. Structure en métal chromé. Diffuseurs supérieurs et inférieurs en verre blanc poli. Les diffuseurs latéraux sont disponibles en verre façonné blanc poli pour la version SO. Pour les versions SO1 et SO2 les diffuseurs latéraux sont disponibles en verre façonné blanc poli, noir poli, rouge poli et en métal à miroir.

Hängeleuchte mit gestreuter Lichtverteilung. Gestell aus verchromtem Metall. Die untere und obere Glasschirme sind weissglänzend. Art. TRIS SO ist mit einem weissem geformtem seitlichem Glasschirm erhältlich. Bei den Art. TRIS SO1 - SO2 ist der seitliche Glasschirm aus geformtem, weissem, rotem, schwarzem Glas, oder aus Spiegelmetall, erhältlich.

Lámpara de suspensión a emisión de luz difusa. Estructura en metal cromado. Difusores inferiores y superiores en vidrio blanco. Difusor lateral en vidrio perfilado blanco en art. TRIS SO. Difusor lateral disponible en los colores blanco, negro, rojo o en metal reflejado en art. TRIS SO1 - SO2.









MODUL
ELECTRO
www.modulelectro.ru

TRIS



TRIS SO1

Project Private house
Location Padova, Italy

Photographer Andrea Pancino

nome name	Tris SO	Tris SO1	Tris SO2
	<p>cables H max cm 200 78.74"</p>  <p>Kg 23</p> <p>cm 100 39.37"</p>	<p>cables H max cm 200 78.74"</p>  <p>cm 60 23.62"</p>	<p>cables H max cm 200 78.74"</p>  <p>cm 36 14.17"</p>
portalampada lamp socket	E27	G9	G9
potenza max max wattage	6x75w	6x60w	3x60w
simbolo symbol			
diffusore diffuser	016	010 016 027 060	010 016 027 060
montatura frame	Cr	Cr	Cr
certificazioni certifications	0.5m CE V PC	0.5m CE V PC	0.5m CE V PC
IP	20	20	20
alimentatore gear	Non richiesto Not required	Non richiesto Not required	Non richiesto Not required

For USA and CANADA

lamp socket	Gx2q-3	Gx2q-3	E12
max wattage	6x26w	3x26w	3x60w
symbol			
Fixture supplied with backplate	NO	NO	NO
Mounts to standard 4" junction box	YES	YES	YES
certifications	UL	UL	UL
gear	Elect. incl.	Elect. incl.	Not required

MODUL
ELECTRO
www.modulelectro.ru



Wall lamp

Pg. 244



Ceiling lamp

Pg. 244



MODUL
ELECTRO
www.modulelectro.ru

UFO

UFO SO

Project S.I.D. headquarters
Location Marcon, Italy

Photographer Andrea Pancino

Lampada a sospensione ad emissione di luce diffusa. Struttura bianca e diffusore interno bianco lucido. Il diffusore esterno, composto da elementi in metacrilato, è disponibile nei colori oro, cromo e bianco. Disponibile a richiesta con alimentatore DALI.

Suspended luminaire for diffused lighting. White frame and inner polished white diffuser. The outer diffuser, composed by a series of acrylic elements, is available in different colours: Gold, Silver and White. Upon request, can be supplied with DALI dimmable electronic ballast.

Lampe à suspension qui répand une clarté diffuse. Structure blanche et diffuseurs internes blancs. Le diffuseur extérieur composé par éléments en méthacrylate est disponible dans les couleurs or, argent et blanc. Disponible sur demande avec alimentation électronique dimmable DALI.

Hängeleuchte mit diffuser Lichtverteilung. Die Metallstruktur ist weiss lackiert und der innere Diffuser ist aus weissem Polycarbonat. Der äussere Methakrylatschirm ist aus verschiedenen Teile zusammengesetzt in den lichtundurchlässigen Farben Gold, Silber und Weiss. Ufo ist eine vielseitige Leuchte, die die Möglichkeit bietet, durch die Kombination der verfügbaren Farben den Diffuser zu individualisieren. Auf Anfrage mit DALI Vorschaltgerät lieferbar.

Lámpara de suspensión de luz difusa. Con estructura blanca y difusor interior blanco. El difusor exterior esta disponible en diferentes colores opacos: Oro, Plata y Blanco. Ufo es un producto muy versátil al ofrecer la posibilidad de personalizar el difusor exterior con las combinaciones de colores disponibles. Disponible bajo pedido con balasto DALI.

MODUL
ELECTRO
www.modulelectro.ru





nome name	UFO S0	UFO S01
portalampada lamp socket	2G11	E27
potenza max max wattage	multiwatt 4x55 or 4x80w	1x60w
simbolo symbol		
diffusore diffuser	Bk Cr Or	Bk Cr Or
montatura frame	Bk	Bk
certificazioni certifications	0.5m CE F PC	0.5m CE F PC
IP	20	20
alimentatore gear	Elettronico incluso Elect. incl.	Not required
lamp socket	2G11	E27
max wattage	4x55w	1x60w
symbol		
Fixture supplied with backplate	NO	NO
Mounts to standard 4\"/>	YES	YES
certifications	UL	UL
gear	Elect. incl.	Not required

MODULO
For USA
and CANADA
ELECTRO
www.modulelectro.ru

Lampada a sospensione ad emissione di luce diretta ed indiretta. Struttura in metallo verniciato bianco. Diffusori superiori a scomparsa in cristallo extra chiaro sabbiato.

Suspended luminaire for direct and indirect lighting. White metal frame. Sanded extra clear crystal upper diffusers.

Suspension émettant un éclairage direct et indirect. Structure en métal verni blanc. Diffuseurs supérieures en cristal extra clair sablé.

Hängeleuchte mit direkter und indirekter Lichtverteilung. Das Metallgestell ist weiss lackiert. Die oberen Abdeckschirmen sind aus sandgestrahltem Kristallglas. Doppelt einschaltbar.

Lámpara de suspensión para iluminación directa y indirecta. Estructura en metal blanco. Difusores superiores en cristal arenado. Equipada con doble interruptor.





MODULO ELECTRO
www.modulelectro.ru

nome name	Zen SO	Zen SO1	Zen SO2	Zen SO3
portalampana lamp socket	G5 + G53	2G11 + G53	R7s 118mm + G53	G5 + G53
potenza max max wattage	2x54w + 3x100w	2x80w + 2x100w	1x200w + 2x100w	2x80w + 4x100w
simbolo symbol				
diffusore diffuser	—	—	—	—
montatura frame	Bk	Bk	Bk	Bk
certificazioni certifications				
IP	20	20	20	20
alimentatore gear	Elettronici inclusi Elect. incl.	Elettronici inclusi Elect. incl.	Elettronico incluso Elect. incl.	Elettronici inclusi Elect. incl.

For USA and CANADA

lamp socket	G5 + 53	2G11 + G53	R7s long + G53	G5 + G53
max wattage	2x54w + 3x50w	2x55w + 2x50w	1x200w + 2x50w	2x80w + 4x50w
symbol				
Fixture supplied with backplate	—	—	—	—
Mounts to standard 4" junction box	—	—	—	—
certifications	—	—	—	—
gear	Elect. incl.	Elect. incl.	Elect. incl.	Elect. incl.



 **MODULO** 
ELECTRO
www.modulelectro.ru



Lampada a sospensione ad emissione di luce diretta ed indiretta. Struttura in metallo bianco con particolari cromati. Vetro bianco lucido o nero lucido applicato nella parte inferiore. Diffusori superiori a scomparsa in cristallo extra chiaro sabbiato.

Suspended luminaire for direct and indirect lighting. White metal frame with chrome accents. White polished or black polished glass placed below. Extra clear sanded crystal hidden diffusers.

Suspension émettant un éclairage direct et indirect. Structure en métal blanc avec détails chromé. Verre blanc poli ou noir poli placé en bas. Diffuseurs supérieurs cachés en crystal extra clair sablé.

Hängeleuchte mit direkter und indirekter Lichtverteilung. Das Metallgestell ist weiss lackiert mit verchromten Metallteile. Die unteren Glasschirmen sind aus weissem oder schwarzem Kristallglas. Die oberen Abdeckschirmen sind aus sandgestrahltem Kristallglas. Doppelt einschaltbar.

Lámpara de suspensión para iluminación directa y indirecta. Estructura en metal blanco con particulares en cromo. Difusores inferiores en cristal blanco o negro. Difusores superiores en cristal arenado. Equipada con doble interruptor.

MODULO
ELECTRO
www.modulelectro.ru

nome name	Zen V SO	Zen V SO1	Zen V SO2
portalampana lamp socket	G5 + G53	2G11 + G53	R7s 118mm + G53
potenza max max wattage	2x54w + 3x100w	2x80w + 2x100w	1x200w + 2x100w
simbolo symbol			
diffusore diffuser	016 027	016 027	027
montatura frame	Bk	Bk	Bk
certificazioni certifications	0.5m CE V PC	0.5m CE V PC	0.5m CE V PC
IP	20	20	20
alimentatore gear	Elettronici inclusi Elect. incl.	Elettronici inclusi Elect. incl.	Elettronici inclusi Elect. incl.

For USA
and CANADA

lamp socket	G5 + 53	2G11 + G53	R7s long + G53
max wattage	2x54w + 3x50w	2x55w + 2x50w	1x200w + 2x50w
symbol			
Fixture supplied with backplate	-	-	-
Mounts to standard 4" junction box	-	-	-
certifications	-	-	-
gear	Elect. incl.	Elect. incl.	Elect. incl.



MODUL
ELECTRO
www.modulelectro.ru



Wall lamp

Pg. 248



MODUL
ELECTRO
www.modulelectro.ru



MODUL
ELECTRO
www.modulelectro.ru











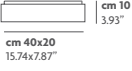

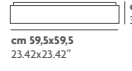



Lampada da parete e soffitto ad emissione di luce diretta e diffusa, struttura in metallo bianco, diffusore in vetro bianco lucido. Doppia accensione.

Ceiling wall mounted luminaire for direct and diffused lighting, in white metal, diffuser in white polished glass diffuser. Double switch.

Applique a plafond émettant un éclairage direct et diffus, structure en métal blanc, diffuseur en verre blanc poli. Double allumage.

Wand- und Deckenleuchte mit diffuser und direkter Lichtverteilung. Das Metallgestell ist weiss lackiert. Schirm aus weissem Klarglas. Doppelt einschaltbar.

Lámpara da pared y de techo para iluminación directa y difusa. Estructura en metal blanco y difusor en vidrio blanco betun. Equipada con doble interruptor.

nome name	A-Box1	A-Box2	A-Box3
	 cm 40x20 15.74x7.87"	 cm 40x45 15.74x17.71"	 cm 59.5x59.5 23.42x23.42"
portalampana lamp socket	G24q-3 + G53	2G11 + G53	2G11 + G53
potenza max max wattage	2x26w + 1x50w	2x36w + 2x50w	2x55w + 3x50w
simbolo symbol	 + 		
diffusore diffuser	016	016	016
montatura frame	Bk	Bk	Bk
certificazioni certifications			
IP	20	20	20
alimentatore gear	Elettronici inclusi Elect. incl.	Elettronici inclusi Elect. incl.	Elettronici inclusi Elect. incl.
For USA and CANADA			
lamp socket	G24q-3 + G53	2G11 + G53	G24q-3 + G53
max wattage	2x26w + 1x50w	2x36w + 2x50w	2x55w + 3x50w
symbol	 + 		
Fixture supplied with backplate	NO	NO	NO
Mounts to standard 4" junction box	YES	YES	YES
certifications			
gear	Elect. incl.	Elect. incl.	Elect. incl.

 Recessed
Pg. 254



MODULO
ELECTRO
www.modulelectro.ru

A-TUBE

DESIGN: ROCCO ESTE, 2009

A-TUBE PL

Project Private villa
Location treviso, Italy

Photographer Andrea Pancino

Lampada da soffitto ad emissione di luce diretta. Struttura in alluminio verniciato bianco. Le versioni PL/PL1/PL2 ruotano a 360° ed inclinano fino a 45°.

Ceiling mounted luminaire for direct lighting. White lacquer, and aluminium frame for direct lighting. The PL/PL1/PL2 versions have a 360° rotation and a 45° tilt. Frame in aluminum.

Plafonnier à émission de lumière indirecte. Structure en aluminium blanc verni. Les versions PL/PL1/PL2 tournent à 360° et l'inclinaison est jusqu'à 45°.

Deckenleuchte mit direkter Lichtverteilung. Die Struktur ist aus weisslackiertem Aluminium. Die Ausführungen PL/PL1/PL2 drehen sich um 360° und neigen sich bis 45°.

Plafón de luz directa. Estructura de aluminio lacado blanco. Las versiones PL/PL1/PL2 giran a 360° y se inclinan hasta 45°.



MODULO
ELECTRO
www.modulelectro.ru



Recessed

Pg. 256



Suspension

Pg. 24

A-TUBE

A-TUBE PL3

Project Private house
Location Jesolo, Italy

Photographer Andrea Pancino

nome name	A-Tube PL	A-Tube PL1	A-Tube PL2	A-Tube PL3
portalampada lamp socket	G53	GX8,5	G53	GU10
potenza max max wattage	1x100w	1x35w	1x10w LED	1x50w or 1x11w
simbolo symbol				or
diffusore diffuser	—	—	—	—
montatura frame	Bk	Bk	Bk	Bk
certificazioni certifications				
IP	20	20	20	20
alimentatore gear	Elettronici incluso Elect. incl.	Elettronici incluso Elect. incl.	Ferromeccanico incluso Magnetic included	Non richiesto Not required

For USA
and CANADA

lamp socket	G53	Available only EU version	Available only EU version	GU10
max wattage	1x100w	Available only EU version	Available only EU version	1x50w
symbol		Available only EU version	Available only EU version	
Fixture supplied with backplate	NO	Available only EU version	Available only EU version	NO
Mounts to standard 4" junction box	YES	Available only EU version	Available only EU version	YES
certifications	—	Available only EU version	Available only EU version	—
gear	Elect. incl.	Available only EU version	Available only EU version	Not required

www.moduloelectro.ru













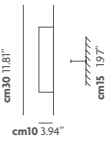
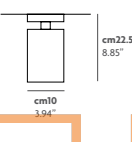

Lampada da parete e soffitto ad emissione di luce diffusa. Struttura in metallo nickel satinato. Diffusore in vetro soffiato bianco opalino satinato.

Wall and ceiling mounted luminaire for diffused lighting. Satin-nickel steel. Metal frame etched opaline white satin hand blown glass diffuser.

Applique plafonnier qui répand une clarté diffuse. Structure en métal nickel satiné. Diffuseur en verre soufflé blanc opalin satiné.

Wand- und Deckenleuchte mit gestreuter Lichtverteilung. Metallgestell aus satiniertem Nickel. Schirm aus weissem, satiniertem, mundgeblasenem Opalglas.

Lámpara da pared y de techo a emisión de luz difusa. Estructura en metal níquel satinado. Difusor en vidrio suplado blanco opalino satinado.

nome name	Alba AP2	Alba PL
		
portalampada lamp socket	G9	E27
potenza max max wattage	2x60w	1x100w
simbolo symbol		
diffusore diffuser		
montatura frame		
certificazioni certifications		
IP	20	20
alimentatore gear	Non richiesto Not required	Non richiesto Not required
For USA and CANADA		
lamp socket	E12	E26
max wattage	2x60w	1x100w
symbol		
Fixture supplied with backplate	YES	YES
Mounts to standard 4" junction box	YES	YES
certifications		



Suspension

Pg. 28

MODULO
ELECTRO
www.modulelectro.ru



Lampada da parete ad emissione di luce diretta e indiretta, struttura in metallo disponibile nei colori bianco o acciaio specchiato.

Wall mounted luminaire for direct and indirect lighting, metal frame available in white or in mirror finish polished stainless steel.

Applique émettant un éclairage direct et indirect, structure en métal, disponible dans les finitions: blanc ou acier miroir.

Wandleuchte mit direkter und indirekter Lichtverteilung. Das Metallgestell kann weiss lackiert oder aus glänzendem Edelstahl sein.

Lámpara de pared para iluminación directa y indirecta. Estructura disponible en metal blanco o en acero inoxidable pulido.



nome name	Andrei AP
portalampana lamp socket	R7s 118mm
potenza max max wattage	1x200w
simbolo symbol	
diffusore diffuser	Al Bk
montatura frame	Bk
certificazioni certifications	0,5m CE V PC
IP	20
alimentatore gear	Non richiesto Not required
For USA and CANADA	
lamp socket	E26
max wattage	2x100w
symbol	
Fixture supplied with backplate	YES
Mounts to standard 4" junction box	YES
certifications	UL
gear	Not required



MODULO
ELECTRO
www.modulelectro.ru



Lampada da parete e soffitto ad emissione di luce diretta, struttura in metallo bianco.

Wall and ceiling mounted luminaire for direct lighting, frame in white metal.

Applique plafonnier émettant un éclairage direct, structure en métal blanc.

Wand- und Deckenleuchte mit direkter Lichtverteilung. Das Metallgestell ist weiss lackiert.

Lámpara da pared y de techo para iluminación directa. Estructura en metal blanco.

nome name	B-Box1	B-Box2	B-Box4
	cm 17x17 6.69" x 6.69"	cm 17x17 6.69" x 6.69"	cm 34x34 13.38" x 13.38"
portalampada lamp socket	G53	G53	G53
potenza max max wattage	1x50w	2x50w	4x50w
simbolo symbol			
diffusore diffuser	—	—	—
montatura frame	Bk	Bk	Bk
certificazioni certifications			
IP	20	20	20
alimentatore gear	Elettronici inclusi Elect. incl.	Elettronici inclusi Elect. incl.	Elettronici inclusi Elect. incl.
For USA and CANADA			
lamp socket	G53	G53	G53
max wattage	1x50w	2x50w	4x50w
symbol			
Fixture supplied with backplate	NO	NO	NO
Mounts to standard 4" junction box	YES	YES	YES
certifications			
gear	Elect. incl.	Elect. incl.	Elect. incl.

Recessed
Pg. 261

BUBBLE

DESIGN: S.I.D., 1950-1982

BUBBLE AP1-PL1

Project Private villa
Location Padova, Italy

Photographer Andrea Pancino

Lampada da parete e soffitto ad emissione di luce diffusa. Struttura in metallo nickel satinato. Diffusore in vetro soffiato bianco satinato.

Wall and ceiling mounted luminaire for diffused lighting. Satin nickel metal. Frame in hand blown white satin glass diffuser.

Applique plafonnier qui répand une clarté diffuse. Structure en métal nickel satiné. Diffuseur en verre soufflé blanc satiné.

Wand- und Deckenleuchte mit gestreuter Lichtverteilung. Metallgestell aus satiniertem Nickel. Glasschirm aus weissem, satiniertem, Mundgeblasenem Glas.

Lámpara da pared y de techo a emisión de luz difusa. Estructura en metal níquel satinado. Difusor en vidrio soplado blanco satinado.



MODULO
ELECTRO
www.modulelectro.ru

nome name	Bubble AP/PL	Bubble AP1/PL1	Bubble AP2/PL2	Bubble AP3/PL3
portalampada lamp socket	2GX13	G9	G9	G9
potenza max max wattage	1x55w	4x40w	3x60w	3x60w
simbolo symbol				
diffusore diffuser	030	030	030	030
montatura frame	Nt	Nt	Nt	Nt
certificazioni certifications				
IP	20	20	20	20
alimentatore gear	Elettronico incluso Elect. incl.	Non richiesto Not required	Non richiesto Not required	Non richiesto Not required
For USA and CANADA				
lamp socket	2GX13	G9	G9	G9
max wattage	1x55w	4x40w	3x60w	3x60w
symbol				
Fixture supplied with backplate	YES	YES	YES	YES
Mounts to standard 4" junction box	YES	YES	YES	YES
certifications				
gear	Elect. incl.	Not required	Not required	Not required



Suspension
Pg. 46



Table lamp
Pg. 294



Floor lamp
Pg. 328

Lampade da parete e soffitto ad emissione di luce diffusa. Struttura in metallo nickel satinato. Diffusore in vetro soffiato "plisse" disponibile nei colori: bianco satinato, rosso lucido e ambra satinato.

Wall and ceiling mounted luminaire for diffused lighting. Satin nickel metal frame. Pleated hand blown glass diffuser, available in the following colours: white satin, amber, and red.

Applique qui répand une clarté diffuse. Structure en métal nickel satiné. Diffuseur en verre soufflé « plissé » disponible dans les couleurs: blanc satiné, ambre et rouge.

Wand- und Deckenleuchte mit gestreuter Lichtverteilung. Metallgestell aus satiniertem Nickel. Der Glasschirm ist aus "plissiertem", mundgeblasenem Glas, und erhältlich in den Farben: Weiss satiniert, satinierten Amber, oder Rot.

Lámpara de pared y de techo a emisión de luz difusa. Estructura en metal níquel satinado. Difusore en vidrio soplado "plisado" disponible en los colores: blanco satinado, ámbar satinado o rojo.

nome name	Clessidra AP	Clessidra AP2	Clessidra AP1	Clessidra PL
portalampana lamp socket	E27	GX24q-3	G9	GU10
potenza max max wattage	2x100w	2x26w	2x40w	1x50w
simbolo symbol				
diffusore diffuser				
montatura frame	Nt	Nt	Nt	Nt
certificazioni certifications				
IP	20	20	20	20
alimentatore gear	Non richiesto Not required	Elettronico incluso Elect. incl.	Non richiesto Not required	Non richiesto Not required

For USA and CANADA

lamp socket	E12	GX24q-3	G9	GU10
max wattage	2x60w	2x26w	2x40w	1x50w
symbol				
Fixture supplied with backplate	YES	YES	YES	NO
Mounts to standard 4" junction box	YES	YES	YES	YES
certifications				
gear	Not required	Elect. incl.	Not required	Not required



Suspension

Pg. 52



Table lamp

Pg. 298





MODUL
ELECTRO
www.modulelectro.ru

Lampada da parete e soffitto ad emissione di luce diffusa. Struttura in metallo nickel satinato. Diffusore in vetro bianco satinato.

Wall and ceiling mounted luminaire for diffused lighting. Satin nickel metal frame. Diffuser in white satin glass.

Applique plafonnier qui répand une clarté diffuse. Structure en métal nickel satiné. Diffuseur en verre blanc satiné.

Wand- und Deckenleuchte mit gestreuter Lichtverteilung. Metallgestell aus satiniertem Nickel. Glasschirm aus weiss satiniertem Glas.

Lámpara de pared y de techo a emisión de luz difusa. Estructura en metal níquel satinado. Difusor disponible en vidrio blanco satinado.

nome name	Crypto PL/API
portalampada lamp socket	R7s 118mm
potenza max max wattage	1x200w
simbolo symbol	
diffusore diffuser	038
montatura frame	Nt
certificazioni certifications	0.5m CE V PC
IP	20
alimentatore gear	Non richiesto Not required
For USA and CANADA	
lamp socket	R7s long
max wattage	1x200w
symbol	
Fixture supplied with backplate	YES
Mounts to standard 4\"/>	YES
certifications	
gear	Not required

MODUL
ELECTRO
www.modulelectro.ru





Lampada da parete e soffitto orientabile ad emissione di luce diffusa. Struttura in metallo disponibile nella versione nickel satinato. Diffusore in vetro bianco lucido.

Adjustable wall and ceiling mounted luminaire for diffused lighting. Frame available in satin nickel metal. White polished glass diffuser.

Applique plafonnier orientable qui répand une clarté diffuse. Structure en métal, disponible dans la finition nickel satiné. Diffuseur en verre blanc poli.







Verstellbare Wandleuchte wand und deckenleuchte mit gestreuter Lichtverteilung. Metallgestell aus satiniertem Nickel. Glasschirm aus weissem, glänzendem Glas.

Lámpara de pared y de techo orientable a emisión de luz difusa. Estructura en metal níquel satinado. Difusor en vidrio blanco lustroso.

MODUL

ELECTRO













www.modulelectro.ru

nome name	Electra AP/PL1
portalamпада lamp socket	R7s 118mm
potenza max max wattage	1x150w
simbolo symbol	
diffusore diffuser	016 
montatura frame	Nt 
certificazioni certifications	0,5m CE  
IP	20
alimentatore gear	Non richiesto Not required
For USA and CANADA	
lamp socket	R7s
max wattage	1x150w
symbol	
Fixture supplied with backplate	YES
Mounts to standard 4" junction box	YES
certifications	
gear	Not required

Lampada da parete ad emissione di luce diretta e diffusa. Struttura in metallo verniciato con particolari in alluminio spazzolato. Diffusori superiore ed inferiore in vetro extra chiaro sabbato, diffusori frontali in vetro bianco lucido o nero lucido.

Wall mounted accertsluminaire for direct and diffused lighting. Lacquered metal with frame brushed aluminium. Upper and lower diffusers in sanded extra clear crystal, front diffusers in black or white polished glass.

Wandleuchte mit direkter und gestreuter Lichtverteilung. Gestell aus lackiertem Metall mit Metallteile aus gebürstetem Aluminium. Oberer und unterer Glasschirm sind aus sandgestrahltem extra-hellem Glas, der vordere Schirm kann aus schwarzem Kristallglas oder aus weissem Kristallglas sein.

nome name	Fly AP	Fly AP1
portalampada lamp socket	G24q-3	R7s 118mm
potenza max max wattage	2x26w	1x200w
simbolo symbol		
diffusore diffuser	 	 
montatura frame	As	As
certificazioni certifications		
IP	20	
alimentatore gear	Elettronico incluso Elect. incl.	Non richiesto Not required
For USA and CANADA		
lamp socket	G24q-3	R7s long
max wattage	2x26w	1x200w
symbol		
Fixture supplied with backplate	YES	YES
Mounts to standard 4" junction box	YES	YES
certifications		
gear	Elect. incl.	Not required

 Suspension
Pg. 60



Lampada da parete angolare ad emissione di luce indiretta, utilizzabile sia in caso di angoli concavi o convessi. Diffusore sostenuto da magneti in acciaio lucido.

Angular wall luminaire for indirect lighting, that can be mounted on both concave and convex angles. The diffuser, in mirror finish polished stainless steel is supported with magnets.

Winkelwandleuchte mit indirekter Lichtverteilung. Verwendbar sowohl bei konkaven als auch bei konvexen Ecken. Der Schirm ist aus hochglanz poliertem Edelstahl und wird von Magneten gehalten. Ist mit EVG ausgestattet.

Winkelwandleuchte mit indirekter Lichtverteilung. Verwendbar sowohl bei konkaven als auch bei konvexen Ecken. Der Schirm ist aus hochglanz poliertem Edelstahl und wird von Magneten gehalten.

Lámpara de pared angular, utilizable sea en caso de ángulos cóncavos o convexos, a emisión de luz indirecta a bajo consumo. Difusor en acero inoxidable con retoque a espejo con soportes magnéticos.



nome
name

Incanto AP

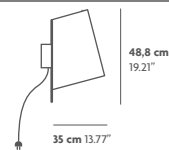

MODULO
ELECTRO

www.modulelectro.com

portalampada lamp socket	G24q-3
potenza max max wattage	4x26w
simbolo symbol	
diffusore diffuser	—
montatura frame	Al
certificazioni certifications	
IP	20
alimentatore gear	Elettronico incluso Elect. incl.
For USA and CANADA	
lamp socket	G24q-3
max wattage	4x26w
symbol	
Fixture supplied with backplate	YES
Mounts to standard 4" junction box	YES
certifications	
gear	Elect. incl.



Lampada da parete e soffitto ad emissione di luce indiretta. Diffusore disponibile in metallo verniciato bianco o in acciaio lucido.

Wall and ceiling mounted luminaire for indirect lighting. Frame available in white lacquered metal and in mirror finish stainless steel.

Applique et plafonnier émettant un éclairage indirect. Structure disponible en métal verni blanc et en acier poli.

Wand- und Deckenleuchte mit indirekter Lichtverteilung. Das Metallgestell kann weiss lackiert oder aus glänzendem Edelstahl sein.

Lámpara de pared y de techo para iluminación indirecta. Estructura disponible en metal blanco o en acero inoxidable pulido.

nome name	Inpiano AP/PL	Inpiano AP1/PL1	Inpiano AP2/PL2	Inpiano AP3/PL3
portalampana lamp socket	2G11	GX24q-4	GX24q-3	G5
potenza max max wattage	2x55w	4x42w	4x26w	2x54w
simbolo symbol				
diffusore diffuser	<input type="checkbox"/> Bk <input type="checkbox"/> Al	<input type="checkbox"/> Bk <input type="checkbox"/> Al	<input type="checkbox"/> Bk <input type="checkbox"/> Al	<input type="checkbox"/> Bk <input type="checkbox"/> Al
montatura frame	<input type="checkbox"/> Bk	<input type="checkbox"/> Bk	<input type="checkbox"/> Bk	<input type="checkbox"/> Bk
certificazioni certifications				
IP	20	20	20	20
alimentatore gear	Elettronico incluso Elect. incl.	Elettronico incluso Elect. incl.	Elettronico incluso Elect. incl.	Elettronico incluso Elect. incl.
For USA and CANADA				
lamp socket	2G11	GX24q-4	GX24q-3	G5
max wattage	2x55w	4x42w	4x26w	2x54w
symbol				
Fixture supplied with backplate	NO	NO	NO	NO
Mounts to standard 4" junction box	YES	YES	YES	YES
certifications				
gear	Elect. incl.	Elect. incl.	Elect. incl.	Elect. incl.



MODUL
ELECTRO
www.modulelectro.ru



Lampade da parete e soffitto ad emissione di luce diffusa. Struttura in metallo cromato. Diffusori in cristallo soffiato e lavorato a mano.

Wall and ceiling mounted luminaires for diffused lighting. Frame in chromed metal. Frame crystal clear blown glass diffusers, hand formed by Murano Masters.

Applique et plafonnier qui répand une clarté diffuse. Structure en métal chromé. Diffuseur en Crystal soufflé travaillé à la main par les Maîtres de Murano.

Wand- und Deckenleuchte mit gestreuter Lichtverteilung. Gestell aus verchromtem Metall. Glasschirm aus handbearbeitetem und von den Murano Meisternmundgeblasenem Kristallglas.

Lámpara de pared y de techo a emisión de luz difusa. Estructura en metal cromado. Difusor en vidrio soplado y hecho a mano por maestros de Murano.

 **MODUL** 
ELECTRO
www.modulelectro.ru







KAPP



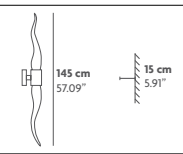
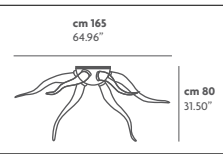

KAPP PL2

Project Private villa
Location Cortina D'Ampezzo, Italy

Photographer Andrea Pancino

nome name	Kapp AP4	Kapp PL2
		
portalampada lamp socket	G9	G9
potenza max max wattage	2x40w	9x40w
simbolo symbol		
diffusore diffuser	000	000
montatura frame	Cr	Cr
certificazioni certifications		
IP	20	20
alimentatore gear	Non richiesto not required	Non richiesto not required

For USA
and CANADA

lamp socket	E12	E12
max wattage	2x40w	9x20w
symbol		
Fixture supplied with backplate	NO	NO
Mounts to standard 4" junction box	YES	YES
certifications		
gear	not required	not required

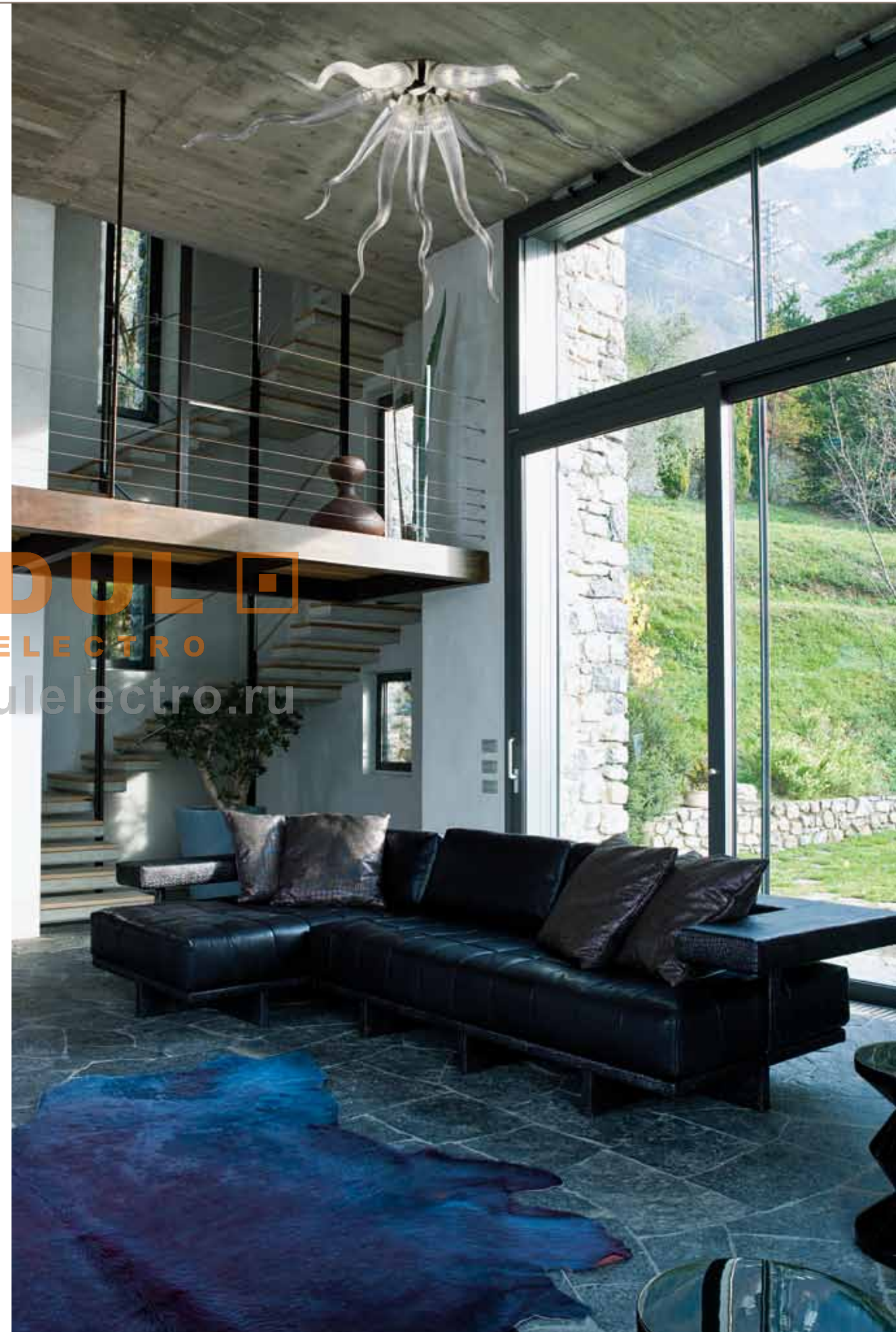

MODULO
ELECTRO
www.modulelectro.ru



Suspension

Pg. 68







Lampada da soffitto ad emissione di luce diretta. Struttura in metallo cromato. Diffusore disponibile in cristallo o vetro bianco lucido con applicazioni di cristallo lavorato a mano dai maestri di Murano.

Ceiling mounted luminaire for direct lighting. Chromed metal frame. Crystal clear or polished white hand blown crystal diffuser with crystal details created by Murano Masters.

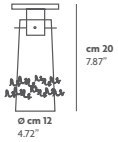
Plafonnier qui répand une clarté directe. Structure en métal chromé. Diffuseur en Crystal ou en verre blanc poli avec des applications en verre travaillé a la main par les Maitres de Murano.

Deckenleuchte mit direkter Lichtverteilung. Gestell aus verchromtem Metall. Glasschirm aus extra-hellem oder aus weissem, glänzendem Kristallglas mit handgemachten Verzierungen.

Lámpara de techo a emisión de luz directa. Estructura en metal cromado. Difusor en cristal transparente o blanco lustroso con aplicaciones de vidrio hecho a mano.

nome name	Lace PL
	
portalampada lamp socket	GU10
potenza max max wattage	1x75w
simbolo symbol	
diffusore diffuser	
montatura frame	
certificazioni certifications	
IP	20
alimentatore gear	Non richiesto Not required
For USA and CANADA	
lamp socket	GU10
max wattage	1x50w
symbol	
Fixture supplied with backplate	NO
Mounts to standard 4" junction box	YES
certifications	
gear	Not required



Suspension

Pg. 72



MODULO
ELECTRO
www.modulelectro.ru



Lampada da parete ad emissione di luce diffusa. Struttura in metallo nickel satinato. Le versioni AP1/AP2 sono disponibili con diffusore in vetro bianco satinato mentre la versione AP4 è disponibile con diffusore in vetro soffiato nei colori bianco satinato, rosso satinato e ambra satinato.

Wall mounted luminaire for diffused lighting. Satin nickel metal frame. The AP1/AP2 versions are available with the white satin glass diffuser and the AP4 version is available with the blown glass diffuser in white satin, red satin and amber satin colours.

Applique qui répand une clarté diffuse. Structure en métal nickel satiné. Les versions AP1/AP2 sont disponibles avec le diffuseur en verre blanc satiné et la version AP4 est disponible avec le diffuseur en verre soufflé dans les couleurs blanc satiné, rouge satiné et ambre satiné.

Wandleuchte mit gestreuter Lichtverteilung. Metallgestell aus satiniertem Nickel. Die Ausführung AP1/AP2 sind mit Glasdiffuser aus weissem, satiniertem Glas verfügbar während bei der Ausführung AP4 ist der satinierte, mundgeblasenem Glasdiffuser in den Farben weiss, rot oder amber verfügbar

Lámpara de pared a emisión de luz difusa. Estructura en metal níquel satinado. El difusor de las versiones AP1/AP2 es blanco satinado mientras el vidrio satinado y suplado de la versión AP4 es blanco, rojo o amber.

MODULO
ELECTRO
www.modulelectro.ru

nome name	Lancia AP1	Lancia AP2	Lancia AP4
portalampada lamp socket			
potenza max max wattage	2x60w	1x28w	2x60w
simbolo symbol			
diffusore diffuser	038	038	028 029 030
montatura frame	Nt	Nt	Nt
certificazioni certifications			
IP	20	20	20
alimentatore gear	Non richiesto Not required	Elettronico incluso Elect. incl.	Non richiesto Not required
For USA and CANADA			
lamp socket	E12	G5	G9
max wattage	2x40w	1x28w	2x40w
symbol			
Fixture supplied with backplate	YES	YES	YES
Mounts to standard 4\"/>	YES	YES	YES
certifications			
gear	Not required	Elect. incl.	Not required



LASER

DESIGN: S.I.D., 2004

LASER AP2

Project Dental clinic
Location Venice, Italy

Photographer Andrea Pancino



Lampada da parete ad emissione di luce indiretta. Struttura in alluminio spazzolato con particolari cromati. Diffusore in vetro extra chiaro sabbiato.

Wall mounted luminaire for indirect lighting. Brushed aluminium frame with chromed accents. Sanded crystal diffuser.

Applique qui répand une clarté indirecte. Structure en aluminium brossé avec des détails chromés. Diffuseur en verre sablé.

Wandleuchte mit indirekter Lichtverteilung. Gestell aus gebürstetem Aluminium mit verchromten Metallteilen. Glasschirm aus sandgestrahltem Glas.

Lámpara de pared a emisión de luz indirecta. Estructura en aluminio cepillado con particulares en cromo. Difusor en vidrio arenado.

 **MODUL** 
ELECTRO
www.modulelectro.ru



LASER

LASER AP4

Project Private villa
Location Padova, Italy

Photographer Andrea Pancino



nome name	Laser/AP2	Laser/AP4
portalampada lamp socket	Rx7s	R7s 118 mm
potenza max max wattage	1x70w	1x200w
simbolo symbol		
diffusore diffuser	O38	O38
montatura frame	As	As
certificazioni certifications	0,5m CE ENEC PC	0,5m CE ENEC PC
IP	20	20
alimentatore gear	Elettronico incluso Elect. incl.	Non richiesto Not required

For USA
and CANADA

MODULO

ELECTRO

www.modulelectro.ru

lamp socket	Available only in EU version	R7s Long
max wattage	Available only in EU version	1x200w
symbol	Available only in EU version	
Fixture supplied with backplate	Available only in EU version	YES
Mounts to standard 4" junction box	Available only in EU version	YES
certifications	Available only in EU version	ADA ETL
gear	Available only in EU version	—



Suspension
Pg. 76



Floor lamp
Pg. 338

LASER CUBE

DESIGN: S.I.D., 2008

LASER CUBE AP6

Project Private house
Location Porto Cervo, Italy

Photographer Andrea Pancino







Lampada da parete ad emissione di luce indiretta. Struttura in metallo disponibile nei colori bianco, ruggine e acciaio spazzolato. Diffusori inclusi (opzionali) in vetro extra chiaro sabbaiato.

Wall mounted luminaire for indirect lighting. Metal frame available in White, rust or brushed stainless steel finish. Optional (included) sanded glass diffusers.

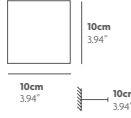
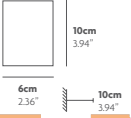
Applique émettant un éclairage indirect. Structure en métal disponible dans le couleurs blanc, rouille ou acier brossé. Diffuseurs optionnels (inclus) en verre sablé.

Wandleuchte mit indirekter Lichtverteilung. Das Metallgestell kann weiss lackiert, aus gebürstetem Edelstahl oder aus oxydiertem Metall sein. Optionaler Schirm aus sandgestrahltem Glas mitgeliefert.

Lampara de pared para iluminación indirecta. Estructura en metal blanco o en acero cepillado. Difusores opcionales en vidrio arenado inclusos.

nome name	Laser AP5	Laser AP6
		
portalampana lamp socket	G9	G9
potenza max max wattage	1x60w	1x60w
simbolo symbol		
diffusore diffuser	038	038
montatura frame	Bk Is Rs	Bk Is Rs
certificazioni certifications		
IP	20	20
alimentatore gear	Non richiesto Not required	Non richiesto Not required
For USA and CANADA		
lamp socket	G9	G9
max wattage	1x60w	1x60w
symbol		
Fixture supplied with backplate	YES	YES
Mounts to standard 4" junction box	YES	YES
certifications	ADA	ADA



Lampade modulari da parete e soffitto ad emissione di luce diffusa. Struttura in metallo cromato con diffusori in vetro soffiato e lavorato a mano disponibili nei colori cristallo, cristallo incamiciato bianco, cristallo incamiciato rosso e cristallo incamiciato nero. Modelli che si prestano a realizzazioni personalizzate.

Modular wall and ceiling lamps for diffused lighting. Chrome metal frame with hand blown and worked glass diffusers, available in crystal, white-crystal, red-crystal and black-crystal. These models lend themselves to a wide range of custom solutions.

Appliques et plafonniers modulables émettant une clarté diffuse. Structure en métal chromé avec diffuseurs en verre soufflé et travaillé à la main, disponible dans les couleurs Crystal, Crystal – blanc et Crystal – rouge, noir et crystal. Modèles qui se prêtent à réalisations personnalisées.

Modulare Wand- und Deckenleuchten mit gestreuter Lichtverteilung. Verchromter Metallgestell. Schirme aus handbearbeitetem und mundgeblasenem Kristallglas, verfügbar in den Farben weiss, rot, schwarze oder durchsichtig. Bietet mehrere individuelle Gestaltungsmöglichkeiten.

Luminarias modulares para techo y pared para iluminación difusa. Lámpara de suspensión a iluminación difusa. Estructura en metal cromado con difusores en vidrio soplado hecho a mano disponibles en cristal, cristal blanco, negro o rojo. Estos modelos se pueden personalizar.

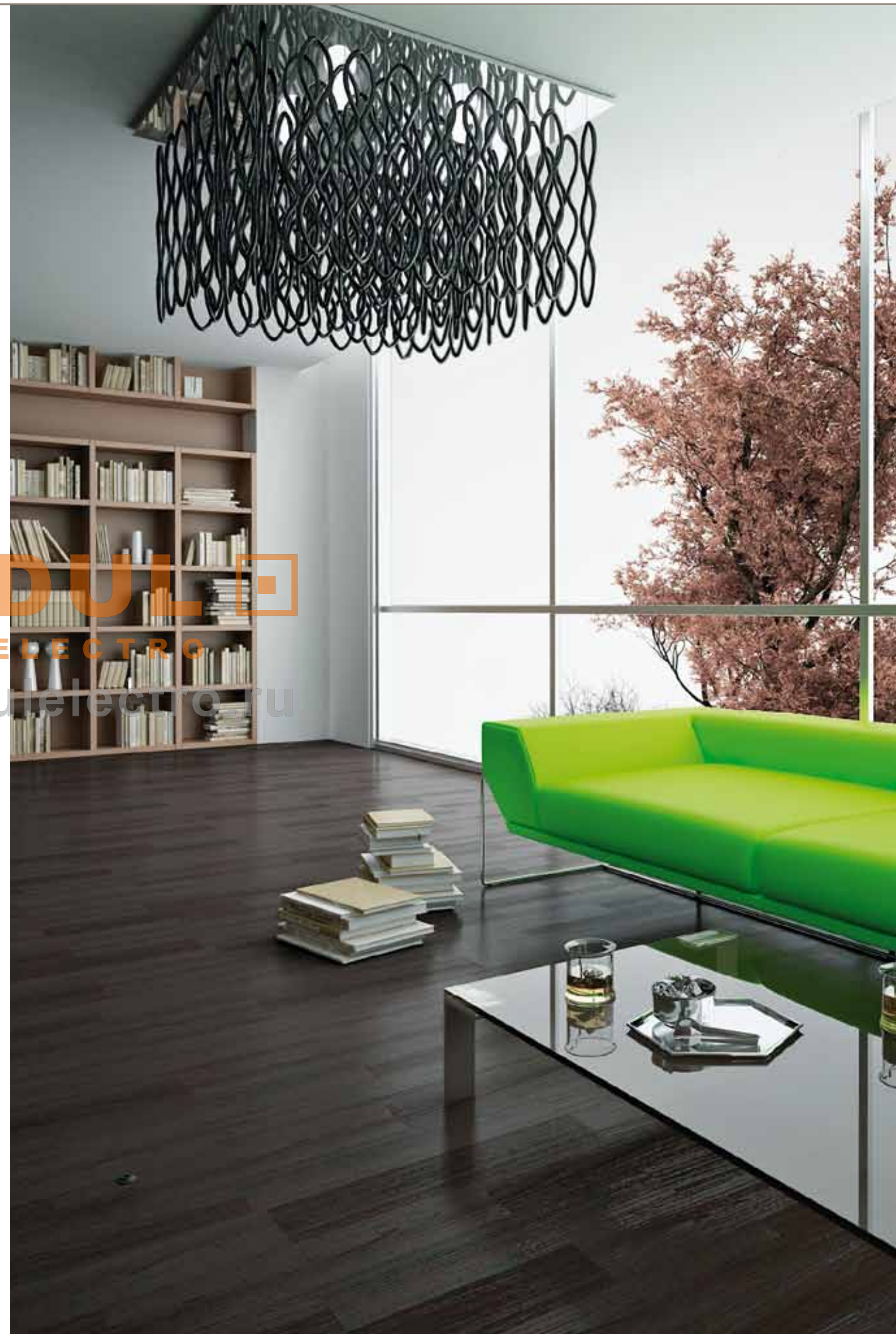

nome name	Lole AP	Lole PL	Lole PL1	Lole PL2	Lole PL3
portalampana lamp socket	E27	E27	E27	E27	E27
potenza max max wattage	2x100w	4x100w	4x100w	4x100w	4x100w
simbolo symbol					
diffusore diffuser	000 016 027 010	000 016 027 010	000 016 027 010	000 016 027 010	000 016 027 010
montatura frame	Cr	Cr	Cr	Cr	Cr
certificazioni certifications	0,5m CE F PG	0,5m CE F PG	0,5m CE F PG	0,5m CE F PG	0,5m CE F PG
IP	20	20	20	20	20
alimentatore gear	Non richiesto Not required	Non richiesto Not required	Non richiesto Not required	Non richiesto Not required	Non richiesto Not required
For USA and CANADA					
lamp socket	E26	E26	E26	E26	E26
max wattage	2x100w	4x100w	4x100w	4x100w	4x100w
symbol					
Fixture supplied with backplate	YES	NO	NO	NO	NO
Mounts to standard 4" junction box	YES	YES	YES	YES	YES
certifications	UL	UL	UL	UL	UL
gear	Not required	Not required	Not required	Not required	Not required



MODULO
ELECTRO
www.modulelectro.ru

Lampada da parete ad emissione di luce diffusa. Struttura in metallo nickel satinato. Diffusore in vetro soffiato bianco satinato.

Wall mounted luminaire for diffused lighting. Satin nickel metal frame. White satin hand blown glass diffuser.





Applique qui répand une clarté diffuse. Structure en métal nickel satiné. Diffuseur en verre soufflé blanc satiné.

Wandleuchte mit gestreuter Lichtverteilung. Metallgestell aus satiniertem Nickel. Glasschirm aus weissem, satiniertem, mundgeblasenem Glas.

Lámpara de pared a emisión de luz difusa. Estructura en metal níquel satinado. Difusor en vidrio soplado blanco satinado.



MODULO
ELECTRO
www.modulelectro.ru

nome name	Ludo AP1	Ludo AP3
portalampada lamp socket	G9	G9
potenza max max wattage	1x60w	2x60w
simbolo symbol		
diffusore diffuser	O30	O30
montatura frame	Nt	Nt
certificazioni certifications	0,5m CE V PC	0,5m CE V PC
IP	20	20
alimentatore gear	Non richiesto Not required	Non richiesto Not required
For USA and CANADA		
lamp socket	G9	G9
max wattage	1x40w	2x40w
symbol		
Fixture supplied with backplate	NO	NO
Mounts to standard 4" junction box	YES	YES
	ADA ETL	ADA ETL



Lampada da parete ad emissione di luce diffusa. Struttura in metallo nickel satinato. Diffusore in vetro soffiato bianco satinato.

Wall mounted luminaire for diffused lighting. Satin nickel metal frame. White satin hand blown glass diffuser.

Applique qui répand une clarté diffuse. Structure en métal nickel satiné. Diffuseur en verre soufflé blanc satiné.

Wandleuchte mit gestreuter Lichtverteilung. Metallgestell aus satiniertem Nickel. Glasschirm aus weissem, satiniertem, mundgeblasenem Glas.

Lámpara de pared a emisión de luz difusa. Estructura en metal níquel satinado. Difusor en vidrio soplado blanco satinado.

nome name	Mabel AP1	Mabel AP2
portalampana lamp socket	E27	R7s 78mm
potenza max max wattage	1x100w	1x150w
simbolo symbol		
diffusore diffuser		
montatura frame		
certificazioni certifications		
IP	20	20
alimentatore gear	Non richiesto Not required	Non richiesto Not required

**For USA
and CANADA**

lamp socket	E26	R7s short
max wattage	1x100w	1x150w
symbol		
Fixture supplied with backplate	YES	YES
Mounts to standard 4" junction box	YES	YES
certifications		
gear	Not required	Not required

Table lamp

Pg. 308

Lampada da soffitto ad emissione di luce diretta. Struttura in metallo microforata disponibile nelle varianti nickel satinato e cromato.

Ceiling mounted luminaire for direct lighting. Micro perforated metal frame, available in satin nickel or chromed finish.

Plafonnier qui répand une clarté directe. Structure en métal micro-percé disponible dans les finitions nickel satiné ou chromé.

Deckenleuchte mit direkter Lichtverteilung. Gelochtem Metallgestell aus satiniertem Nickel oder verchromt.

Lámpara de techo a emisión de luz directa. Estructura en metal micro-agujerada disponible en las variantes níquel satinado o cromada.

nome name	Mania PL3
portalampana lamp socket	GU10
potenza max max wattage	1x50w
simbolo symbol	
diffusore diffuser	—
montatura frame	Cr Nt
certificazioni certifications	
IP	20
alimentatore gear	Non richiesto Not required
For USA and CANADA	
lamp socket	GU10
max wattage	1x50w
symbol	
Fixture supplied with backplate	NO
Mounts to standard 4" junction box	YES
certifications	



MODULO
ELECTRO
www.modulelectro.ru



Suspension

Pg. 82







Lampada da soffitto ad emissione di luce diretta e diffusa. Struttura in metallo nickel satinato. Diffusore in vetro disponibile nei colori bianco satinato, cristallo, rosso trasparente e marrone lucido.

Ceiling mounted luminaire for diffused and direct lighting. Satin nickel metal frame. Glass diffuser available in white satin, crystal, transparent red and polished brown.

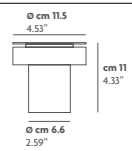
Plafonnier qui répand une clarté directe et diffuse. Structure en métal nickel satiné. Diffuseur en verre disponible dans les couleurs blanc satiné, crystal, rouge transparent et marron poli.

Deckenleuchte mit direkter und gestreuter Lichtverteilung. Metallgestell aus satiniertem Nickel. Der mundgeblasene Glasschirm kann weiss satiniert, rot durchsichtig, braun glänzend oder aus durchsichtigem Kristallglas sein.

Lámpara de techo a emisión de luz directa y difusa. Estructura en metal níquel satinado. Difusor en vidrio disponible en las variantes blanco opalino satindo, cristal transparente, rojo, transparente o marrón encamisado lustroso.

nome name	Mania V PL4
	
portalampana lamp socket	GU10
potenza max max wattage	1x50w
simbolo symbol	
diffusore diffuser	
montatura frame	Nt
certificazioni certifications	
IP	20
alimentatore gear	Non richiesto Not required
For USA and CANADA	
lamp socket	GU10
max wattage	1x50w
symbol	
Fixture supplied with backplate	NO
Mounts to standard 4" junction box	YES
certifications	
gear	Not required



Suspension

Pg. 84



MODULO
ELECTRO
www.modulelectro.ru



Lampade da parete e soffitto ad emissione di luce diffusa. Struttura in metallo verniciato bianco con particolari cromati.

Wall and ceiling mounted luminaire for diffused lighting. White lacquered metal frame with chrome accents.

Applique qui répand une clarté diffuse. Structure en métal verni blanc avec détails en chrome.

Wand- und Deckenleuchte mit gestreuter Lichtverteilung. Die Metallstruktur ist weiss lackiert mit verchromte Metallteile.

Lámpara de pared y de techo de luz difusa. Estructura de metal lacado blanco y particulares en metal cromado.

nome name	Maya AP	Maya PL
portalampada lamp socket	GX24q-3	GX24q-3
potenza max max wattage	2x26w	2x26w
simbolo symbol		
diffusore diffuser	—	—
montatura frame	Bk	Bk
certificazioni certifications		
IP	20	20
alimentatore gear	Elettronico incluso Elect. incl.	Elettronico incluso Elect. incl.

**For USA
and CANADA**

lamp socket	GX24q-3	GX24q-3
max wattage	2x26w	2x26w
symbol		
Fixture supplied with backplate	NO	NO
Mounts to standard 4" junction box	YES	YES
certifications		
gear	Elect. incl.	Elect. incl.



Suspension

Pg. 88

Lampada da parete e soffitto orientabile ad emissione di luce diretta per versioni 1 e 1P, diretta e diffusa nelle versioni 2 e 2P. Le versioni 1 e 1P sono disponibili nelle finiture galvaniche nickel satinato e cromato e nelle finiture verniciate bianco, giallo, fucsia, verde acido e nero. Le versioni 2 e 2P sono disponibili con struttura a finitura galvanica nickel satinato e cromato e nella finitura verniciata bianco, il diffusore in vetro soffiato è disponibile nei colori bianco satinato, ambra satinato, rosso satinato e marrone lucido. Le versioni 1P e 2P sono dotate di interruttore sulla base. La versione 0 è fissa con struttura verniciata bianca il diffusore in vetro soffiato è disponibile nei colori bianco satinato, ambra satinato, rosso satinato e marrone lucido.

Wall and ceiling mounted adjustable luminaire for direct lighting in the 1 and 1P versions, for direct and diffused lighting in the 2 and 2P versions. The 1 and 1P versions are available in nickel satin and chrome in plated finishes and in white, yellow, fuchsia, acid green and black lacquered in painted finishes. The 2 and 2P versions are available in the nickel satin and chrome in plated finishes. In the white lacquered model the blown glass diffuser is available with white satin, amber satin, red satin or polished brown. The 1P and 2P versions have a switch in the base of the frame. The 0 version has a white lacquered frame and is not adjustable. The hand-blown glass diffuser is available in satin, amber satin, red satin or polished brown finishing.

Applique et plafonnier orientable qui répand une clarté directe dans la version 1 et 1P, direct et diffuse dans les versions 2 et 2P. Les versions 1 et 1P sont disponibles dans les finitions galvaniques nickel satiné et chrome et dans les finitions vernies blanc, jaune, fuchsia, vert acide et blanc. Les versions 2 et 2P sont disponibles avec la monture galvanisée nickel satiné et chrome et vernie blanc, le diffuseur en verre soufflé est disponible dans les couleurs blanc satiné, ambre satiné, rouge satiné et marron poli. Les versions 1P et 2P sont fournis avec le bouton d'allumage sur la monture. La version 0 n'est pas orientable, la monture est vernie blanc et le diffuseur en verre soufflé est disponible dans les couleurs blanc satiné, ambre satiné, rouge satiné et marron poli.

Verstellbare Wand- und Deckenleuchte mit direkter Lichtverteilung bei den 1 und 1P Ausführungen, mit direkter und gestreuter Lichtverteilung bei den 2 und 2P Ausführungen. Die Ausführungen 1 und 1P sind aus Nickel satiniertem, verchromtem, weisslackiertem, gelblackiertem, fuchsinrotlackiertem, grünlackiertem oder Schwarzlackiertem Metall. Die Metallstruktur der 2 und 2P Ausführungen kann Nickel satiniert, verchromt oder weisslackiert sein, der mundgeblasene Glasschirm kann weiss satiniert, amber satiniert, rot satiniert oder braun glänzend sein. Die 1P und 2P Ausführungen werden mit einem im Gestell eingebauten Schalter hergestellt. Die 0 Ausführung ist nicht verstellbar, die Metallstruktur ist weisslackiert und der mungeblasene Glasschirm kann weiss satiniert, amber satiniert, rot satiniert oder braun glänzend sein.

Lámpara de pared y de techo orientable a emisión de luz directa por las versiones 1 y 1P y a emisión de luz directa y difusa por las versiones 2 y 2P. Las versiones 1 y 1P son disponibles en las variantes níquel satinado, cromada, pintada blanca, pintada amarillo, pintada rosa, pintada verde o pintada negra. La estructura metálica de las versiones 2 y 2P son en níquel satinado, cromada o pintada blanca, el difusor suplado es disponible en blanco satinado, amber satinado, rojo satinado o marron lustroso. Las versiones 1 y 1P son suministrados con pulsante de encendido en el montaje. La version 0 es ficha, la estructura metálica es pintada blanca y el difusor suplado es disponible en blanco satinado, amber satinado, rojo satinado o marron lustroso.

nome name	Minimania 1	Minimania 1/P
portalampada lamp socket	GU10	GU10
potenza max max wattage	1x75w	1x75w
simbolo symbol		
diffusore diffuser	—	—
montatura frame	Cr Nt Bk Fu Ag Ye	Cr Nt Bk
certificazioni certifications	0,5m CE V PC	0,5m CE V PC
IP	20	20
alimentatore gear	Non richiesto Not required	Non richiesto Not required
lamp socket	GU10	GU10
max wattage	1x60w	1x60w
simbolo symbol		
Fixture supplied with backplate	YES	YES
Mounts to standard 4" junction box	YES	YES
certificazioni certifications	ETL ADA	ETL ADA
gear	Not required	Not required





MODUL
ELECTRO
www.modulelectro.ru



MINIMANIA

MINIMANIA 2

Project The Westin Garden City Hotel Architect Chhada Siembieda, Australia
Location Mumbai, India



nome name	Minimania 2	Minimania 2/P	Minimania 0
portalampana lamp socket	G9	G9	G9
potenza max max wattage	1x60w	1x60w	1x60w
simbolo symbol			
diffusore diffuser			
montatura frame	Cr Nt Bk	Cr Nt Bk	Bk
certificazioni certifications	0,5m ⚡ CE V PC	0,5m ⚡ CE V PC	0,5m ⚡ CE V PC
IP	20	20	20
alimentatore gear	Non richiesto Not required	Non richiesto Not required	Non richiesto Not required
lamp socket	G9	G9	G9
max wattage	1x40w	1x40w	1x40w
symbol			
Fixture supplied with backplate	YES	YES	YES
Mounts to standard 4" junction box	YES	YES	YES
certifications			
gear	Not required	Not required	Not required



Table lamp

Pg. 312

Lampada da soffitto ad emissione di luce diretta e diffusa. Struttura in metallo verniciato. Diffusore in vetro disponibile nei colori bianco e ambra satinati.

Ceiling mounted luminaire for diffused and direct lighting. Lacquered metal frame. Glass diffuser available in white and amber.

Plafonnier qui répand une clarté directe et diffuse.
Structure en métal verni. Diffuseur en verre disponible dans les couleurs blanc et ambre.

Deckenleuchte mit direkter und gestreuter Lichtverteilung. Gestell aus lackiertem Metall. Der satinierte Glasschirm kann weiss, oder amber sein.

Lámpara de techo a emisión de luz directa y difusa. Estructura en metal barnizado. Difusor en vidrio disponible en los colores blanco o ámbar.



nome
name

Miù PL

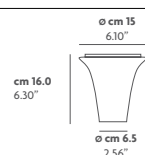

MODULO
ELECTRO
www.modulelectro.ru

portalampada lamp socket	E27
potenza max max wattage	1x150w
simbolo symbol	
diffusore diffuser	030 029
montatura frame	Bk
certificazioni certifications	0,5m
IP	20
alimentatore gear	Non richiesto Not required
For USA and CANADA	
lamp socket	E26
max wattage	1X60w
symbol	
Fixture supplied with backplate	NO
Mounts to standard 4" junction box	YES
gear	Not required



Lampada da parete e soffitto ad emissione di luce diffusa. Diffusore in vetro soffiato bianco satinato. E' dotata di un filtro rosso (opzionale) incluso.



Wall and ceiling mounted luminaire for diffused lighting. White satin blown glass diffuser. Red (optional) extra diffuser included.

Applique et plafonnier qui répand une clarté diffuse. Diffuseur en verre soufflé blanc satiné. Extra diffuseur rouge (optionnel) inclus.

Wand- und Deckeneuchte mit gestreuter Lichtverteilung. Der Diffuser ist aus mundgeblasenem, weiss satiniertem Glas. Es wird ein optionaler roter Filter mitgeliefert.

Lámpara de pared y de techo a emisión de luz difusa. Difusor de cristal soplado blanco satinado. Filtro de metalcristalo rojo incluido opcional.

nome name	Ombra AP/PL	Ombra AP1/PL1	Ombra AP2/PL2
portalampana lamp socket	2GX13	G24Xq-3	G9
potenza max max wattage	1x22w + 1x40w	2x26w	3x40w
simbolo symbol			
diffusore diffuser			
montatura frame	Bk	Bk	Bk
certificazioni certifications			
IP	20	20	20
alimentatore gear	Elettronico incluso Elect. incl.	Elettronico incluso Elect. incl.	Non richiesto Not required
For USA and CANADA			
lamp socket	2GX13	G24q-3	G9
max wattage	1x22w + 1x40w	2x26w	3x40w
symbol			
Fixture supplied with backplate	NO	NO	NO
Mounts to standard 4" junction box	YES	YES	YES
certifications			-
gear	Elect. incl.	Elect. incl.	Not required

 **MODUL** 
ELECTRO
www.modulelectro.ru

Lampada da parete e soffitto ad emissione di luce diffusa. Struttura in metallo nickel satinato. Diffusore e vetro di protezione in vetro extra chiaro sabbiato.

Wall and Ceiling mounted luminaire for diffused lighting. Satin nickel metal frame. Sanded crystal diffuser and safety glass.

Applique et Plafonnier qui répand une clarté diffuse. Structure en métal nickel satiné. Diffuseur et verre de protection en verre sablé.

Wand- und Deckenleuchte mit gestreuter Lichtverteilung. Metallgestell aus satiniertem Nickel. Schirm und Schutzglas aus sandgestrahltem Glas.

Lámpara de pared y de techo a emisión de luz difusa. Estructura en metal níquel satinado. Difusor y vidrio de protección en pirex arenado.



MODULO
ELECTRO
www.modulelectro.ru

nome name	Polis AP/PL	Polis AP1/PL1	Polis AP2/PL2
portalampada lamp socket	G5	G5	R7s 118mm
potenza max max wattage	1x54w	1x24w	1x200w
simbolo symbol			
diffusore diffuser	038	038	038
montatura frame	Nt	Nt	Nt
certificazioni certifications			
IP	20	20	20
alimentatore gear	Elettronico incluso Elect. incl.	Elettronico incluso Elect. incl.	Non richiesto Not required

**For USA
and CANADA**

lamp socket	G5	G5	R7s long
max wattage	1x54w	1x24w	1x200w
symbol			
Fixture supplied with backplate	NO	NO	NO
Mounts to standard 4" junction box	YES	YES	YES
certifications			
gear	Elect. incl.	Elect. incl.	Not required



Lampada da parete ad emissione di luce diffusa. Struttura in metallo nickel spazzolato. Diffusore in vetro extra chiaro sabbiato.

Wall mounted luminaire for diffused lighting. Brushed nickel metal frame. Frosted extra clear glass diffuser.

Applique qui répand une clarté diffuse. Structure en métal nickel brossé. Diffuseur en verre extra-claire satinée.

Wandleuchte mit gestreuter Lichtverteilung. Metallgestell aus gebürstetem Nickel. Schirm aus satiniertem, extra- hellem Kristallglas.

Lámpara de pared a emisión de luz difusa. Estructura en metal níquel cepillado. Difusor en cristal extra claro satinado.

nome name	Prima AP2	Prima AP2F
portalampana lamp socket	R7s 118 mm	G24q-2
potenza max max wattage	1x200w	2x18w
simbolo symbol		
diffusore diffuser	038	038
montatura frame	Ns	Ns
certificazioni certifications		
IP	20	20
alimentatore gear	Non richiesto Not required	Elettronico incluso Elect. incl.
For USA and CANADA		
lamp socket	R7s Long	G24q-2
max wattage	1x200w	2x18w
symbol		
Fixture supplied with backplate	YES	YES
Mounts to standard 4" junction box	YES	YES
certifications		
gear	Not required	Elect. incl.

Lampade da parete e plafoniera ad emissione di luce diffusa. Struttura in metallo nickel satinato. Diffusore in metacrilato trasparente. PURALUCE R - G - G1 corrispondono a rosone e ganci per composizioni a parete. Il rosone è fornito su richiesta con la quantità di fori necessari al collegamento multiplo.

Wall and ceiling mounted luminaire for diffused lighting. Satin nickel metal frame. Clear acrylic diffuser. PURALUCE R - G - G1 are accessories (ceiling canopy and hooks) for wall installations. The ceiling canopy (PURALUCE R) is supplied upon request with the holes required for multiple wiring.

Applique et plafonnier qui répand une clarté diffuse. Structure en métal nickel satiné. Diffuseur en méthacrylate transparent. PURALUCE R - G - G1, patères et broches pour la composition d'appliques à plusieurs lumières. La patère (PURALUCE R) est fournie sur demande, selon le nombre de trous nécessaires pour les raccordements multiples.

Wand- und Deckenleuchte mit gestreuter Lichtverteilung. Metallgestell aus satiniertem Nickel. Schirm aus durchsichtigem Methacrylat. Art. PURALUCE R - G - G1 betrachten Baldachin und verschiedene Hacken um eine Zusammensetzung von mehreren Grundelementen auf der Wand zu ermöglichen; der Baldachin wird auf Anfrage mit mehreren Kabelauslässen hergestellt, um mehrere Grundelemente zu kombinieren.

Lámpara de pared y de techo a emisión de luz difusa. Estructura en metal níquel satinado. Difusor en metacrilato transparente. PURALUCE accesorios R - G - G1, roseton y ganchos para fijar y componer unas lámparas en la pared; el roseton se puede solicitar con el número de agujeros necesario para la conexión eléctrica.











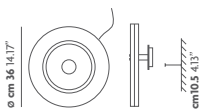
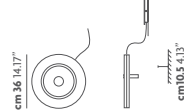
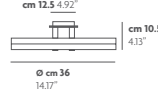



MODULO
ELECTRO
www.modulelectro.ru





PURALUCE

PURALUCE

Project Private house
Location Milan, Italy

nome name	Puraluce base	Puraluce AP	Puraluce AP1	Puraluce PL
				
portalampada lamp socket	2GX13	2GX13	2GX13	2GX13
potenza max max wattage	1x22w	1x22w	1x22w	1x22w
simbolo symbol				
diffusore diffuser	000	000	000	000
montatura frame	Nt	Nt	Nt	Nt
certificazioni certifications				
IP	40	40	40	40
alimentatore gear	Electronico incluso Elect. incl.	Electronico incluso Elect. incl.	Electronico incluso Elect. incl.	Electronico incluso Elect. incl.
accessori accessory				

For USA

lamp socket	2GX13	2GX13	2GX13	2GX13
max wattage	1x22w	1x22w	1x22w	1x22w
symbol				
Fixture supplied with backplate	NO	NO	NO	NO
Mounts to standard 4" junction box	YES	YES	YES	YES
certifications	—	—	—	—
gear	Elect. incl.	Elect. incl.	Elect. incl.	Elect. incl.



Suspension
Pg. 100



Table lamp
Pg. 314





Lampada da parete ad emissione di luce indiretta. Disponibile nelle finitura galvanica nickel satinato e bianco verniciato.

Wall mounted luminaire for indirect lighting. Available in satin nickel plated finish or in lacquered white.

Applique qui répand une clarté indirecte. Disponible dans la finition galvanisée nickel satiné et verni blanc.

Wandleuchte mit indirekter Lichtverteilung. Verfügbar aus satiniertem Nickel oder weiss lackiert.

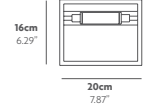
Lámpara de pared a emisión de luz indirecta. La Estructura metalica disponible en níquel satinado o pintada blanca.

nome name	Sail AP2
	
portalampada lamp socket	R7s 78mm
potenza max max wattage	1x150w
simbolo symbol	
diffusore diffuser	—
montatura frame	Cr Bk
certificazioni certifications	0,5m CE V PC
IP	20
alimentatore gear	Non richiesto Not required

**For USA
and CANADA**

lamp socket	R7s short
max wattage	1x150w
symbol	
Fixture supplied with backplate	YES
Mounts to standard 4" junction box	YES
certifications	—

Lampada da parete ad emissione di luce diffusa. Struttura in metallo nickel satinato. Diffusore in vetro extra chiaro sabbiato.

Wall mounted luminaire for diffused lighting. Satin nickel metal frame. Frosted white glass diffuser.

Applique qui répand une clarté diffuse. Disponible dans la finition nickel satiné. Diffuseur en verre blanc opalin satiné.

Wandleuchte mit gestreuter Lichtverteilung. Metallgestell aus satiniertem Nickel. Schirm aus sandgestrahltem, extra-hellem Glas.

Lámpara de pared a emisión de luz difusa. Estructura en metal níquel satinado. Difusor en cristal extra claro arenado.



MODULO
ELECTRO
www.modulelectro.ru

nome name	Sail V AP1	Sail V AP F
portalampada lamp socket	R7s 78 mm	G24q-2
potenza max max wattage	1x200w	1x18w
simbolo symbol		
diffusore diffuser	038	038
montatura frame	Nt	Nt
certificazioni certifications		
IP	20	20
alimentatore gear	Non richiesto Not required	Elettronico incluso Elect. incl.
For USA and CANADA		
lamp socket	R7s short	G24q-2
max wattage	1x200w	1x18w
symbol		
Fixture supplied with backplate	YES	YES
Mounts to standard 4" junction box	YES	YES
certifications		
gear	Not	Elect. incl.



SAX

SAX AP2-PL2

Project Studium associates
Location Venezia, Italy

Photographer Andrea Pancino

Lampada da parete e soffitto orientabile ad emissione di luce diretta. Struttura in alluminio spazzolato con particolari cromati.

Adjustable wall and ceiling mounted luminaire for direct lighting. Brushed aluminium frame with chrome accents.

Applique et plafonnier orientable qui répand une clarté directe. Structure en aluminium brossé avec des détails chromés.

Verstellbare Wand- und Deckenleuchte mit direkter Lichtverteilung. Gestell aus gebürstetem Aluminium mit verchromten Metallteilen.

Lámpara de pared y de techo orientable a emisión de luz directa. Estructura en aluminio cepillado con particulares cromados.

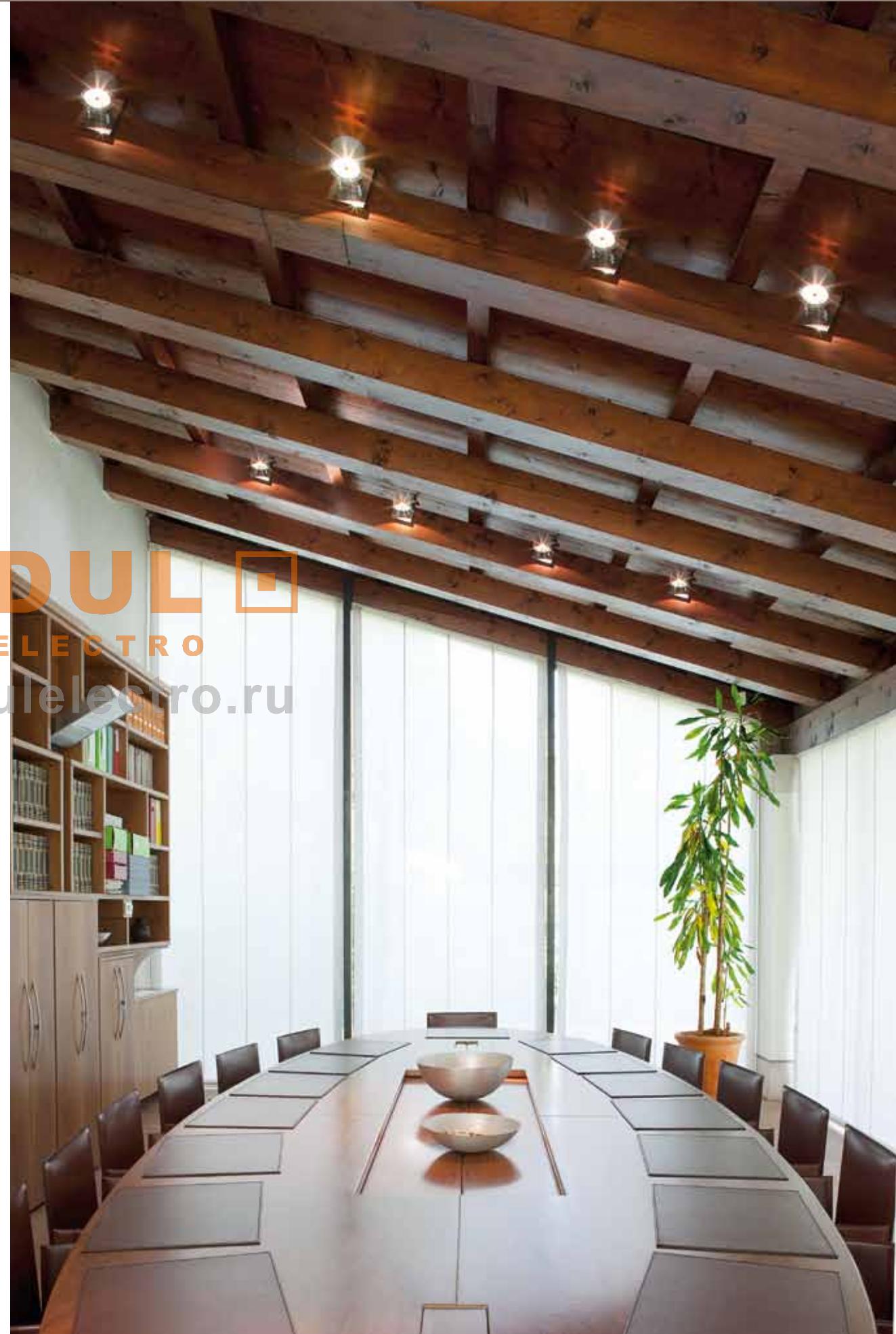

nome name	Sax AP	Sax AP2/PL2	Sax AP3/PL3
portalampana lamp socket	G53	G53	G53
potenza max max wattage	2x50w	1x50w	2x50w
simbolo symbol			
diffusore diffuser	—	—	—
montatura frame	As	As	As
certificazioni certifications			
IP	20	20	20
alimentatore gear	Elettronico incluso Elect. incl.	Elettronico incluso Elect. incl.	Elettronico incluso Elect. incl.
For USA and CANADA			
lamp socket	G53	G53	G53
max wattage	2x35w	1x35w	2x35w
symbol			
Fixture supplied with backplate	YES	NO	NO
Mounts to standard 4\"/>	YES	YES	YES
certifications	—	—	—
gear	Elect. incl.	Elect. incl.	Elect. incl.











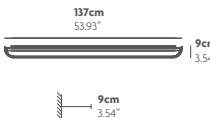
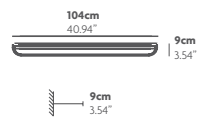
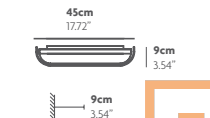
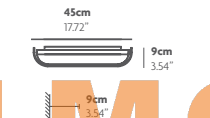





Lampade da parete ad emissione di luce indiretta. Struttura in metallo verniciato bianco.

Wall mounted luminaires for indirect lighting. White lacquered metal frame.

Applique émettant un éclairage indirect. Structure en métal verni blanc.

Wandleuchten mit indirekter Lichtverteilung. Das Metallgestell ist weiss lackiert.

Lámparas de pared para iluminación indirecta. Estructura en metal blanco.

nome name	Slim AP4	Slim AP5	Slim AP6	Slim AP7
				
portalampada lamp socket	2G11	2G11	G24q-3	R7s 118mm
potenza max max wattage	2x80w	2x36w	2x26w	1x150w
simbolo symbol				
diffusore diffuser	—	—	—	—
montatura frame	Bk	Bk	Bk	Bk
certificazioni certifications				
IP	20	20	20	20
alimentatore gear	Elettronico incluso Elect. incl.	Elettronico incluso Elect. incl.	Elettronico incluso Elect. incl.	Non richiesto Not required
For USA and CANADA				
lamp socket	2G11	2G11	G24q-3	R7s long
max wattage	2x55w	2x36w	2x26w	1x150w
symbol				
Fixture supplied with backplate	YES	YES	YES	YES
Mounts to standard 4" junction box	YES	YES	YES	YES
certifications				
gear	Elect. incl.	Elect. incl.	Elect. incl.	Not required





MODUL
ELECTRO
www.modulelectro.ru



Lampada da parete con struttura in metallo verniciato bianco e ruggine. La versione AP è a doppia emissione di luce indiretta superiore alogena e inferiore a LED. Doppia accensione. Le versioni AP1 e AP2 hanno emissione di luce indiretta.

Wall mounted luminaire with white lacquered and rust coloured frame. The AP version has a double indirect light source: halogen above and Led below. Equipped with double switch. The AP1 and AP2 version are for indirect lighting.

Applique avec la structure en métal verni blanc et rouille. La version AP est à double émission d'éclairage indirecte: halogène supérieur et led inférieur. Double allumage. Les versions AP1 et AP2 ont une émission d'éclairage indirecte.

Wandleuchte mit weisslackiertem oder oxydiertem Metallgestell. Die Ap Version ist mit einer zweifachen Lichtverteilung ausgestattet: eine durch Halogen Leuchtmittel und die andere durch LED. Doppelt einschaltbar. Die AP1 und Ap2 Versionen gewährleisten eine indirekte Lichtverteilung.

Lámpara de pared con estructura, en metal disponible en las variantes en metal blanco o herrumbroso. La versión AP es equipada con doble flujo luminoso: halógeno y por LED. Equipada con doble interruptor. Las versiones AP1 y AP2 son para iluminación indirecta.

MODULO
ELECTRO
www.modulelectro.ru

nome name	Snake AP	Snake AP1	Snake AP2
portalampana lamp socket	R7s 118mm Dragon-X L12W	R7s 118 mm	G24q3
potenza max max wattage	1x150w + 1x1,2w LED	1x150w	1x26w
simbolo symbol			
diffusore diffuser	—	—	—
montatura frame	<input type="checkbox"/> Bk <input type="checkbox"/> Rs	<input type="checkbox"/> Bk <input type="checkbox"/> Rs	<input type="checkbox"/> Bk <input type="checkbox"/> Rs
certificazioni certifications			
IP	20	20	20
alimentatore gear	Incluso per LED Included for LED	Non richiesto Not required	Elettronico incluso Elect. incl.
For USA and CANADA			
lamp socket	Available only EU version	R7s long	G24q3
max wattage	Available only EU version	1x150w	1x26w
symbol	Available only EU version		
Fixture supplied with backplate	Available only EU version	YES	YES
Mounts to standard 4" junction box	Available only EU version	YES	YES
certifications	Available only EU version	—	
gear	Available only EU version	Not required	Elect. incl.

Lampada da parete ad emissione di luce diffusa. Struttura in metallo disponibile nelle versioni in nickel satinato o cromato. Diffusore in cristallo trasparente con all'interno un tubo in vetro pirex sabbato.

Wall mounted luminaire for diffused lighting. Frame available in satin nickel or chromed metal. Diffuser in crystal clear with an inner sanded Pyrex glass tube.

Applique qui répand une clarté diffuse. Structure en métal disponible en nickel-satiné ou chromé. Diffuseur en verre transparente avec un tube pyrex sablé à l'intérieur.

Wandleuchte mit gestreuter Lichtverteilung. Metallgestell aus satiniertem Nickel oder verchromt. Glasschirm aus durchsichtigem Kristall mit einem inneren sandgestrahlten Schutzglas.

Lámpara de pared a emisión de luz difusa. Estructura en metal disponible en las variantes en níquel satinado o cromado. Difusor en cristal transparente con al interior un tubo pirex arenado.



nome name	Sophie AP2	Sophie AP1
portalampada lamp socket	G9	G9
potenza max max wattage	2x40w	1x40w
simbolo symbol		
diffusore diffuser	—	—
montatura frame	Cr Nt	Cr Nt
certificazioni certifications		
IP	44	44
alimentatore gear	Non richiesto Not required	Non richiesto Not required
For USA and CANADA		
lamp socket	G9	G9
max wattage	2x40w	1x40w
symbol		
Fixture supplied with backplate	NO	NO
Mounts to standard 4" junction box	YES	YES
certifications		
gear	Not required	Not required

MODULO
ELECTRO
www.modulelectro.ru





Lampada da parete orientabile a 360° ad emissione di luce diretta. Struttura in alluminio anodizzato.

360° adjustable wall mounted luminaire for direct lighting. Anodised aluminium frame.

Applique orientable à 360° qui répand une clarté directe. Structure en aluminium anodisé.

360° verstellbare Wandleuchte mit direkter Lichtverteilung. Gestell aus eloxiertem Aluminium.

Lámpara de pared orientable a 360° a emisión de luz directa. Estructura en aluminio anodizado.

nome name	Spotty AP
	
portalampada lamp socket	GX53
potenza max max wattage	1x13w
simbolo symbol	
diffusore diffuser	—
montatura frame	
certificazioni certifications	
IP	20
alimentatore gear	non richiesto not required
For USA and CANADA	
lamp socket	Available only in EU version
max wattage	-
symbol	Available only in EU version
Fixture supplied with backplate	Available only in EU version
Mounts to standard 4" junction box	Available only in EU version
gear	Available only in EU version

MODULO
ELECTRO
www.modulelectro.ru





Lampada da parete ad emissione di luce diffusa. Struttura in metallo cromato, diffusore in vetro bianco lucido.



Wall lamp for diffused lighting. Chromed metal frame, white polished glass diffuser.

Applique émettant une clarté diffuse. Structure en métal blanc et diffuseur en verre blanc poli.

Wandleuchte mit gestreuter Lichtverteilung. Das Metallgestell ist verchromt. Schirm aus weissem, glänzendem Glas.

Lampara de pared a emisión de luz difusa. Estructura en metal cromado, difusor en vidrio blanco lustroso.

MODULO
ELECTRO
www.modulelectro.ru

nome name	Square AP
portalampana lamp socket	G9
potenza max max wattage	1x40w
simbolo symbol	
diffusore diffuser	016
montatura frame	Cr
certificazioni certifications	0,5m CE V PC
IP	44
alimentatore gear	Non richiesto Not required
For USA and CANADA	
lamp socket	G9
max wattage	1x40w
symbol	
Fixture supplied with backplate	YES
Mounts to standard 4" junction box	YES
certifications	-
gear	Not required

Lampada da parete e soffitto ad emissione di luce diffusa. Struttura in metallo cromato. Diffusore superiori ed inferiori in vetro bianco lucido. I diffusori laterali sono disponibile in vetro sagomato bianco lucido per versione AP/PL. Per le versioni AP1/PL1 e AP2/PL2 i diffusori laterali sono disponibili in vetro bianco lucido, nero lucido, rosso lucido e metallo specchiato.

Wall and ceiling mounted luminaire for diffused lighting. Chrome metal frame. Upper and lower diffusers in polished white glass. Side diffusers are available in polished white shaped glass for the AP/PL version. For the AP1/PL1 and AP2/PL2 versions, the side diffusers are available in polished white, polished black, polished red and mirror finish metal.

Applique qui répand une clarté diffuse. Structure en métal chromé. Diffuseurs supérieurs et inférieurs en verre blanc poli. Les diffuseurs latérales sont disponibles en verre façonné blanc pour la version AP/PL. Pour les versions AP1/PL1 et AP2/PL2 les diffuseurs latérales sont disponibles en verre façonné blanc poli, noir poli, rouge poli et en métal à miroir.

Wand- und Deckenleuchte mit gestreuter Lichtverteilung. Gestell aus verchromtem Metall. Die untere und obere Glasschirme sind weisssglänzend. Art. TRIS AP ist mit einem weissem geformtem seitlichem Glasschirm erhältlich. Bei den Art. TRIS AP1 - AP2 ist der seitliche Glasschirm aus geformtem weissem, rotem, oder schwarzem Glas, oder aus Spiegelmetall erhältlich.

Lámpara de pared a emisión de luz difusa. Estructura en metal cromado. Difusores avanos y superiores en vidrio blanco. Difusor lateral en vidrio perfilado blanco en art. TRIS AP. Difusor lateral disponible en los colores blanco, negro, rojo o en metal reflejado en art. TRIS AP1 - AP2.

MODULO
ELECTRO
www.modulelectro.ru



TRIS

TRIS PL2

nome name	Tris AP/PL	Tris AP1/PL1	Tris AP2/PL2
portalampada lamp socket	E27	G9	G9
potenza max max wattage	6x75w	6x60w	3x60w
simbolo symbol			
diffusore diffuser	016	010 016 027 060	010 016 027 060
montatura frame	Cr	Cr	Cr
certificazioni certifications	0,5m CE F PC	0,5m CE F PC	0,5m CE F PC
IP	20	20	20
alimentatore gear	Non richiesto Not required	Non richiesto Not required	Non richiesto Not required
For USA and CANADA			
lamp socket	GX24q-3	G24q-3	E12
max wattage	6x26w	3x26w	3x60w
symbol			
Fixture supplied with backplate	NO	NO	NO
Mounts to standard 4\"/>	YES	YES	YES
certifications	UL	UL	UL ADA
gear	Elect. incl.	Elect. incl.	Not required

MODULO
ELECTRO
www.modulelectro.ru



Suspension

Pg. 120



Lampada da parete ad emissione di luce indiretta e diretta direzionabile. Struttura in metallo verniciato bianco. Doppia accensione.

Wall mounted luminaire for indirect and adjustable direct lighting. White lacquered metal frame. Double switch.

Applique émettant un éclairage indirect et direct orientable. Structure en métal verni blanc. Double allumage.

Wandleuchte mit direkter und indirekter Lichtverteilung. Das Metallgestell ist weiss lackiert. Doppelt einschaltbar.

Lámpara de pared para iluminación directa e indirecta, estructura en metal blanco. Equipada con doble interruptor.

nome name	Zen AP
	
porta lampada lamp socket	G24q-3 + GU10
potenza max max wattage	2x26w + 2x50w
simbolo symbol	
diffusore diffuser	038
montatura frame	Bk
certificazioni certifications	
IP	20
alimentatore gear	Elettronico incluso Elect. incl.
For USA and CANADA	
lamp socket	G24q-3 + GU10
max wattage	2x26w + 2x50w
symbol	
Fixture supplied with backplate	YES
Mounts to standard 4" junction box	YES
certifications	—
gear	Elect. incl.



Suspension

Pg. 132

Apparecchio da incasso installabile a cartongesso e laterizio con relativa cassaforma, ad emissione di luce diretta e diffusa. Struttura in metallo bianco, diffusore in vetro bianco lucido. Doppia accensione.

Recessed fixture for brickwork or plasterwork installation, with the proper back box. Installation for direct and diffused lighting. White metal frame, polished white glass diffuser. Double switch.

Appareil encastré installable dans le mur brique et, avec le boîtier adapté, dans le placoplâtre, émettant un éclairage direct et diffus. Structure en métal blanc, diffuseur en verre blanc poli. Double allumage.

Einbauleuchte mit gestreuter und direkter Lichtverteilung. Das Metallgestell ist weiss lackiert. Schirm aus weissem Glas. Doppelt einschaltbar. Die Leuchte ist mittels Einbausetts sowohl in einer Gips- als auch in einer Betonwand installierbar.







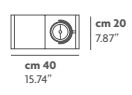
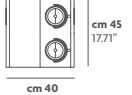
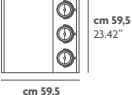
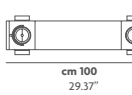

Lámpara para iluminación directa y difusa. Estructura en metal blanco y difusor en vidrio blanco. Equipada con doble interruptor. Su instalación se adapta al "cartón yeso" (pladur) y también en paredes y techos de obra mediante un marco para facilitar la instalación.

www.modulelectro.ru









A-BOX

A-BOX 1

nome name	A-Box1	A-Box2	A-Box3	A-Box4
				
portalampada lamp socket	G24q-3 + G53	2G11 + G53	2G11 + G53	2G11 + G53
potenza max max wattage	2x26w + 1x50w	2x36w + 2x50w	2x55w + 3x50w	2x80w + 2x50w
simbolo symbol				
diffusore diffuser	016	016	016	016
montatura frame	Bk	Bk	Bk	Bk
certificazioni certifications				
IP	20	20	20	20
alimentatore gear	Elettronici inclusi Elect. incl.	Elettronici inclusi Elect. incl.	Elettronici inclusi Elect. incl.	Elettronici inclusi Elect. incl.



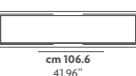
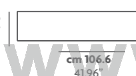

Cornice per cartongesso
Frame for plasterwork installation

Cassaforma per laterizio
Back box for brickwork

accessori accessory	AB1	AB2	AB3	AB4	AB5	AB6	AB7	AB8
								

cartongesso plasterwork	cm 40.8x20.8 16.06"x8.18"	47x45.8cm 18.50"x18.03"	60.3x60.3cm 23.74"x23.74"	101x21cm 39.76"x8.26"
laterizio brickwork	cm 40.8x20.8 16.06"x8.18"	cm 45.8x40.8 18.03"x16.06"	cm 60.3x60.3 23.74"x23.74"	101x21cm 39.76"x8.26"

For USA
and CANADA

lamp socket	G24q-3 + G53	2G11 + G53	2G11 + G53	2G11 + G53
max wattage	2x26w + 1x50w	2x36w + 2x50w	2x55w + 3x50w	2x55w + 2x50w
symbol				
Fixture supplied with backplate	NO	NO	NO	NO
Mounts to standard 4" junction box	YES	YES	YES	YES
certifications	—	—	—	—
gear	Elect. incl.	Elect. incl.	Elect. incl.	Elect. incl.



Wall lamp

Pg. 144



Ceiling lamp

Pg. 144



A-TUBE

DESIGN: ROCCO ESTE, 2010

A-TUBE

Project Broker office
Location Palermo, Italy

Photographer Andrea Pancino







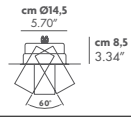

Apparecchio da incasso direzionabile installabile a cartongesso ad emissione di luce diretta. Struttura in metallo disponibile nelle finiture verniciate bianco e nero.

Adjustable recessed fixture for plasterwork installation, for direct lighting. Metal frame available in white and black finishes.

Appareil à encastrer orientable installable dans le placoplâtre, émettant un éclairage direct. Structure en métal disponible dans les finitions blanc et noir.

Orientierbare Einbauleuchte mit direkter Lichtverteilung. In Gipsdecken einsetzbar. Das Metallgestell kann weiss oder schwarz lackiert sein.

Luminaria empotrable orientable que se adapta al "carton yeso" para luz directa. Estructura en metal disponible en blanco o negro.

nome name	A-Tube INC
	
portalampada lamp socket	GU10
potenza max max wattage	1x50w or 1x11w
simbolo symbol	 or 
diffusore diffuser	—
montatura frame	<input type="checkbox"/> Bk <input type="checkbox"/> Nr
certificazioni certifications	   
IP	20
alimentatore gear	Non richiesto Not required
cartongesso plasterwork	 \varnothing 130 51.18"
For USA and CANADA	
lamp socket	GU10
max wattage	1x50w
symbol	
Fixture supplied with backplate	NO
Mounts to standard 4" junction box	NO
certifications	—
gear	Not required



Suspension

Pg. 24



Ceiling lamps

Pg. 146









MODUL
ELECTRO
www.modulelectro.ru



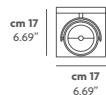
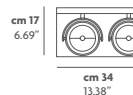
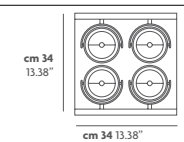





 **MODUL** 
ELECTRO
www.modulelectro.ru

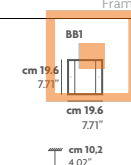
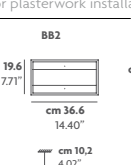
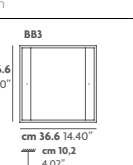
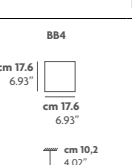
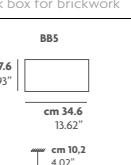
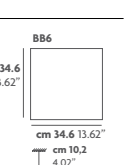

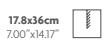







nome name	B-Box1	B-Box2	B-Box3
			
portalampada lamp socket	G53	G53	G53
potenza max max wattage	1x50w	2x50w	4x50w
simbolo symbol			
diffusore diffuser	—	—	—
montatura frame	Bk	Bk	Bk
certificazioni certifications			
IP	20	20	20
alimentatore gear	Elettronico incluso Elect. incl.	Elettronico incluso Elect. incl.	Elettronico incluso Elect. incl.

	Cornice per cartongesso Frame for plasterwork installation			Cassaforma per laterizio Back box for brickwork		
accessori accessory						
cartongesso plasterwork						
laterizio brickwork						

**For USA
and CANADA**

lamp socket	G53	G53	G53
max wattage	1x50w	2x50w	4x50w
symbol			
Fixture supplied with backplate	NO	NO	NO
Mounts to standard 4" junction box	YES	YES	YES
certifications			
gear	Elect. incl.	Elect. incl.	Elect. incl.

 Ceiling lamp

BASKET

DESIGN: S.I.D., 2010

BASKET

Project Broker office
Location Palermo, Italy

Photographer Andrea Pancino

Apparecchio da incasso orientabile ed estraibile installabile a cartongesso ad emissione di luce diretta. Struttura in metallo verniciato bianco.

Adjustable and extractable recessed fixture for plasterwork installation, for direct lighting. White lacquered metal frame.







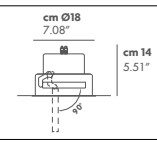
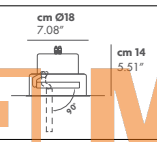

Appareil à encastrer orientable et extractible installable dans le placoplâtre, émettant un éclairage direct. Structure en métal blanc verni.

Orientier- und ausziehbare Einbauleuchte mit direkter Lichtverteilung. In Gipsplatte einsetzbar. Weisslackierter Metallgestell.

Luminaria empotrable orientable y extraíble que se adapta al «carton yeso» (pladur) para luz directa. Estructura en metal blanco.



MODULO
ELECTRO
www.modulelectro.ru

nome name	Basket INC1	Basket INC2
		
portalampana lamp socket	G53	G53
potenza max max wattage	1x50w	1x10w LED
simbolo symbol		
diffusore diffuser	—	—
montatura frame	Bk	Bk
certificazioni certifications		
IP	20	20
alimentatore gear	Elettronico non incluso Elect. not incl.	Ferromagnetico non incluso Magnetic not incl.
cartongesso plasterwork		
For USA and CANADA		
lamp socket	GU10	Available only in EU version
max wattage	1x50w	Available only in EU version
symbol		Available only in EU version
Fixture supplied with backplate	NO	Available only in EU version
Mounts to standard 4" junction box	NO	Available only in EU version
certifications	—	Available only in EU version
gear	Elect. not incl.	Available only in EU version



MODUL
ELECTRO
www.modulelectro.ru

Apparecchi da incasso installabili a cartongesso ad emissione di luce diretta e diffusa. Struttura in metallo cromato, diffusore in cristallo.

Recessed fixtures for plasterwork installation, for direct and diffused lighting. Chromed metal frame, crystal diffuser.

Appareils encastrés installables dans le placo-plâtre, émettant un éclairage direct et diffus. Structure en métal chromé, diffuseur en cristal.

Einbauleuchten mit direkter und gestreuter Lichtverteilung. Gestell aus verchromtem Metall mit einem Schirm aus durchsichtigem Kristallglas. Die Leuchte ist nur in einer Gipswand installierbar.

Lámpara de techo para iluminación directa y difusa. Estructura en metal cromado y difusor en cristal transparente. Se puede instalar solamente en "cartón yeso (pladur)".

nome name	Cambio INC	Campy INC	Twin INC
portalampana lamp socket	GU10	GU10	GU10
potenza max max wattage	1x50w	1x50w	1x50w
simbolo symbol			
diffusore diffuser	000	000	000
montatura frame	Cr	Cr	Cr
certificazioni certifications			
IP	20	20	20
alimentatore gear	Non richiesto Not required	Non richiesto Not required	Non richiesto Not required
cartongesso plasterwork			
For USA and CANADA			
lamp socket	GU10	GU10	GU10
max wattage	1x50w	1x50w	1x50w
symbol			
Fixture supplied with backplate	NO	NO	NO
Mounts to standard 4" junction box	YES	YES	YES
certifications			
gear	Not required	Not required	Not required





Apparecchio da incasso installabile a cartongesso e laterizio con relativa cassaforma, a luce diretta. Struttura in metallo verniciato bianco con diffusore in vetro bianco lucido. Le versioni INC4-INC5 sono modulari e a richiesta possono essere modulate anche le altre versioni. Alimentatore DALI disponibile su richiesta per tutti i modelli.

Recessed fixture for brickwork or plasterboard installation with the proper back box. For direct lighting, white lacquered metal frame. INC4 and INC5 are modular versions and, upon request, can be modulated even the other versions. DALI ballast available, upon request, for all the versions.

Appareil encastré installable avec le boîtier adapté dans le mur brique et dans le placoplâtre, émettant un éclairage direct. Structure en métal blanc avec diffuseur en verre blanc poli. Les versions INC4 et INC5 sont modulables et, sur demande, on peut moduler même les autres versions. Le ballast DALI est disponible, sur demande, pour toutes les versions.

Innen-Einbauleuchte aus weisslackiertem Metall mit direkter Lichtausstrahlung. Der Glasdiffuser ist aus weissem Opalglas. Die Versionen INC4 und INC5 sind modulierbar, auf Anfrage sind auch alle andere Versionen modulierbar. Die Leuchten sind mittels Einbausets sowohl in einer Gips- als auch in einer Betonwand installierbar. Auf Anfrage alle Versionen sind mit DALI Vorschaltgerät ausrüstbar.

Luminaria empotrable de iluminación interior y luz directa, estructura de metal lacado blanco, con difusor de cristal blanco lustroso. Las versiones INC4 y INC5 son modular. Su instalación se adapta al "cartón yeso" (pladur) y también en paredes y techos de obra mediante un marco para facilitar la instalación. Disponible bajo pedido con balasto dimmerable Dalí.

MODUL
ELECTRO
www.modulelectro.ru



iLINE

nome name	iLine INC1	iLine INC2	iLine INC3
portalampada lamp socket	G5	G5	G5
potenza max max wattage	1x24w	1x39w	1x54w
simbolo symbol			
diffusore diffuser	016	016	016
montatura frame	Bk	Bk	Bk
certificazioni certifications			
IP	20	20	20
alimentatore gear	Elettronico incluso Elect. incl.	Elettronico incluso Elect. incl.	Elettronico incluso Elect. incl.
accessori accessory			
cartongesso plasterwork	cm 5x60.5 1.97"x23.81"	cm 5x90.5 1.97"x35.62"	cm 5x120.5 1.97"x47.44"
laterizio brickwork	cm 5x60.5 1.97"x23.81"	cm 5x90.5 1.97"x35.62"	cm 5x120.5 1.97"x47.44"
<p>For USA and CANADA</p>			
lamp socket	G5	G5	G5
max wattage	1x24w	1x39w	1x54w
symbol			
Fixture supplied with backplate	NO	NO	NO
Mounts to standard 4" junction box	YES	YES	YES
certificazioni certifications	—	—	—
gear	Elect. incl.	Elect. incl.	Elect. incl.

nome name	iLine INC4	iLine INC5
portalampada lamp socket	G5	G5
potenza max max wattage	1x39w	1x39w
simbolo symbol		
diffusore diffuser	016	016
montatura frame	Bk	Bk
certificazioni certifications		
IP	20	20
alimentatore gear	Elettronico incluso Elect. incl.	Elettronico incluso Elect. incl.
cartongesso plasterwork	cm 5x89.8 1.97"x35.35"	cm 5x89.8 1.97"x35.35"
laterizio brickwork	cm 5x89.8 1.97"x35.35"	cm 5x89.8 1.97"x35.35"
lamp socket	T5	T5
max wattage	1x39w	1x39w
symbol		
Fixture supplied with backplate	NO	NO
Mounts to standard 4" junction box	YES	YES
certificazioni certifications	—	—
gear	Elect. incl.	Elect. incl.



1. Chiuso/Aperto - Closed/Open - Fermè/Ouvert - Geschlossen/Offen - Cerrado/Abierto
2. Aperto/Aperto - Open/Open - Ouvert/Ouvert - Offen/Offen - Abierto/Abierto
3. Aperto/Chiuso - Open/Closed - Ouvert/Fermè - Offen/Geschlossen - Abierto/Cerrado

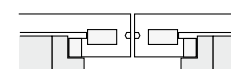

Senza interruzione di luce anche con composizioni continue
 Seamless line of light also on continuous compositions
 Sans interruption de la lumière aussi avec une composition continuee
 Ohne Lichtunterbrechung auch bei zusammensetzung von mehrere elemente
 Sin interrupción de luz también con composición continua

Esempio di componibilità
 Example of line composition
 Exemple de composition
 Lichtobjekt zusammengestellt
 Ejemplo de componibilidad



MODUL
ELECTRO
www.modulelectro.ru

Apparecchio da incasso installabile a cartongesso e laterizio con relativa cassaforma, a luce diretta, in metallo verniciato bianco, utilizzabile come segna passo o come luce d'ambiente. Mascherina esterna in policarbonato disponibile nei colori rosso, nero, bianco e cromo intercambiabile.

Recessed fixture for brickwork or plasterboard installation with the proper back box. For direct lighting, made in white lacquered metal, can be used as a step light or for general ambient lighting. Polycarbonate interchangeable outer mask, available in red, black, white and chrome colours.

Appareil encastré installable avec le boîtier adapté dans le mur brique et dans le placoplâtre, émettant un éclairage direct, en métal verni blanc, utilisable pour le balisage ou la lumière d'ambiance. Masque extérieure interchangeable en polycarbonate disponible dans les couleurs rouge, noir, blanc et chrome.

Innen-Einbauleuchte mit direkter Lichtverteilung. Gestell aus weiss lackiertem Metall. Ist als Wegmarkierung oder als Ambiente-Beleuchtung einsetzbar. Der austauschbare Polykarbonatschirm kann in den Farben Rot, Schwarz, Weiss oder Chrom sein. Die Leuchte ist mittels Einbausets sowohl in einer Gips- als auch in einer Betonwand installierbar.

Luminaria empotrable de iluminación interior y luz directa. Estructura de metal lacado blanco, para instalar en zonas de paso o como luz de ambiente. Su instalación se adapta al "cartón yeso" (pladur) y también en paredes de ladrillo mediante un marco para facilitar la instalación.

www.modulelectro.ru





Apparecchio da incasso orientabile installabile a cartongesso ad emissione di luce diretta. Struttura in metallo verniciato bianco con cono diffusore nero antiabbagliamento.

Adjustable recessed fixture for plasterwork installation, for direct lighting. White metal frame with black anti-glare cone diffuser.

Appareil à encastrer orientable installables dans le placoplâtre, émettant un éclairage direct. Structure en métal blanc avec un diffuseur conique noir anti-éblouissement.

Orientierbare Einbauleuchte mit direkter Lichtverteilung. In Gipsappedecken einsetzbar. Weisslackierte Metallstruktur mit einem schwarzem, abblendendem Kegel Diffusor.

Luminaria empotrable y orientable que se adapta al «carton yeso» para emisión de luz directa. Estructura en metal blanco con cono difusor negro antideslumbrante.

nome name	Pina INC1	Pina INC2	Pina INC3	Pina INC4
portalampanada lamp socket				
potenza max max wattage	1x50w	1x7w CREE LED	1x50w	1x7w CREE LED
simbolo symbol				
diffusore diffuser	—	—	—	—
montatura frame	Bk	Bk	Bk	Bk
certificazioni certifications				
IP	20	20	20	20
alimentatore gear	Elettronico non incluso Elect. not incl.	Ferromagnetico non incluso Magnetic not incl.	Elettronico non incluso Elect. not incl.	Ferromagnetico non incluso Magnetic not incl.
cartongesso plasterwork				

**For USA
and CANADA**

lamp socket	GU5,3	Available only EU version	GU5,3	Available only EU version
max wattage	1x50w	Available only EU version	1x50w	Available only EU version
symbol		Available only EU version		Available only EU version
Fixture supplied with backplate	NO	Available only EU version	NO	Available only EU version
Mounts to standard 4" junction box	NO	Available only EU version	NO	Available only EU version
certifications	—	Available only EU version	—	Available only EU version
gear	Elect. not incl.	Available only EU version	Elect. not incl.	Available only EU version



MODULO
ELECTRO
www.modulelectro.ru

Apparecchio da incasso installabile a cartongesso ad emissione di luce diretta. Struttura in metallo verniciato bianco.









Recessed fixture for plasterwork installation, for direct lighting. White metal frame.

Appareil à encastrer installable dans le placoplâtre, émettant un éclairage direct. Structure en métal blanc.

In Gipspappedecken einsetzbare Einbauleuchte mit gestreuter Lichtverteilung. Weisslackierte Metallstruktur.

Luminaria enpotrable que se adapta al «carton yeso» para emision de luz directa. Estructura en metal blanco.

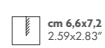

nome name	Panico INC1	Panico INC2
portalam-pada lamp socket	 cm 10,8 4.25" cm 8x8 3.14x3.14"	 cm 10,8 4.25" cm 8x8 3.14x3.14"
potenza max max wattage	GU5,3	GU5,3
simbolo symbol	1x50w	1x7w CREE LED
diffusore diffuser		
montatura frame	—	—
certificazioni certifications		
IP	Bk	Bk
alimentatore gear	Elettronico non incluso Elect. not incl.	Ferromagnetico non incluso Magnetic not incl.
cartongesso plasterwork	 cm 6,6x7,2 2.59x2.83"	 cm 6,6x7,2 2.59x2.83"
For USA and CANADA		
lamp socket	GU5,3	Available only in EU version
max wattage	1x50w	Available only in EU version
symbol		Available only in EU version
Fixture supplied with backplate	NO	Available only in EU version
Mounts to standard 4" junction box	NO	Available only in EU version
certifications	—	Available only in EU version
gear	Not required	Available only in EU version







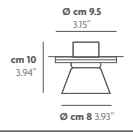

Apparecchio da incasso installabile a cartongesso ad emissione di luce diretta e diffusa. Struttura in metallo nickel spazzolato. Diffusore disponibile nelle varianti: metallo cromato microforato ed in vetro bianco lucido.

Recessed fixture for plasterwork installation for direct and diffused lighting. Brushed nickel metal frame. Diffuser available in micro-perforated chromed metal and in white polished glass.

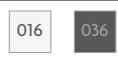
Encastré installable dans le placopatre qui répand une clarté directe et diffuse. Structure en métal nickel-brossé. Diffuseur disponible en métal chromé micro-percé et en verre blanc poli.

Einbauleuchte mit gestreuter und direkter Lichtverteilung. Metallgestell aus gebürstetem Nickel. Schirm aus weissem mundgeblasenem Opalglas oder aus gelochten, verchromten Metall. Die Leuchte ist nur in einer Gipswand installierbar.

Lámpara empotrables a emisión de luz directa y difusa. Estructura en metal níquel cepillado. Difusor disponible en las variantes: metal cromado micro-agujerado o en vidrio opalino blanco. Se puede instalar solamente en "cartón yeso (pladur)".

nome name	Split INC
	
portalampana lamp socket	GU5,3
potenza max max wattage	1x35w
simbolo symbol	
diffusore diffuser	
montatura frame	
certificazioni certifications	
IP	20
alimentatore gear	Electronico escluso Elect. not incl.
cartongesso plasterwork	
For USA and CANADA	
lamp socket	GU5,3
max wattage	1x35w
symbol	
Fixture supplied with backplate	NO
Mounts to standard 4" junction box	YES
certifications	
gear	Elect. not incl.

MODULO
ELECTRO
www.modulelectro.ru



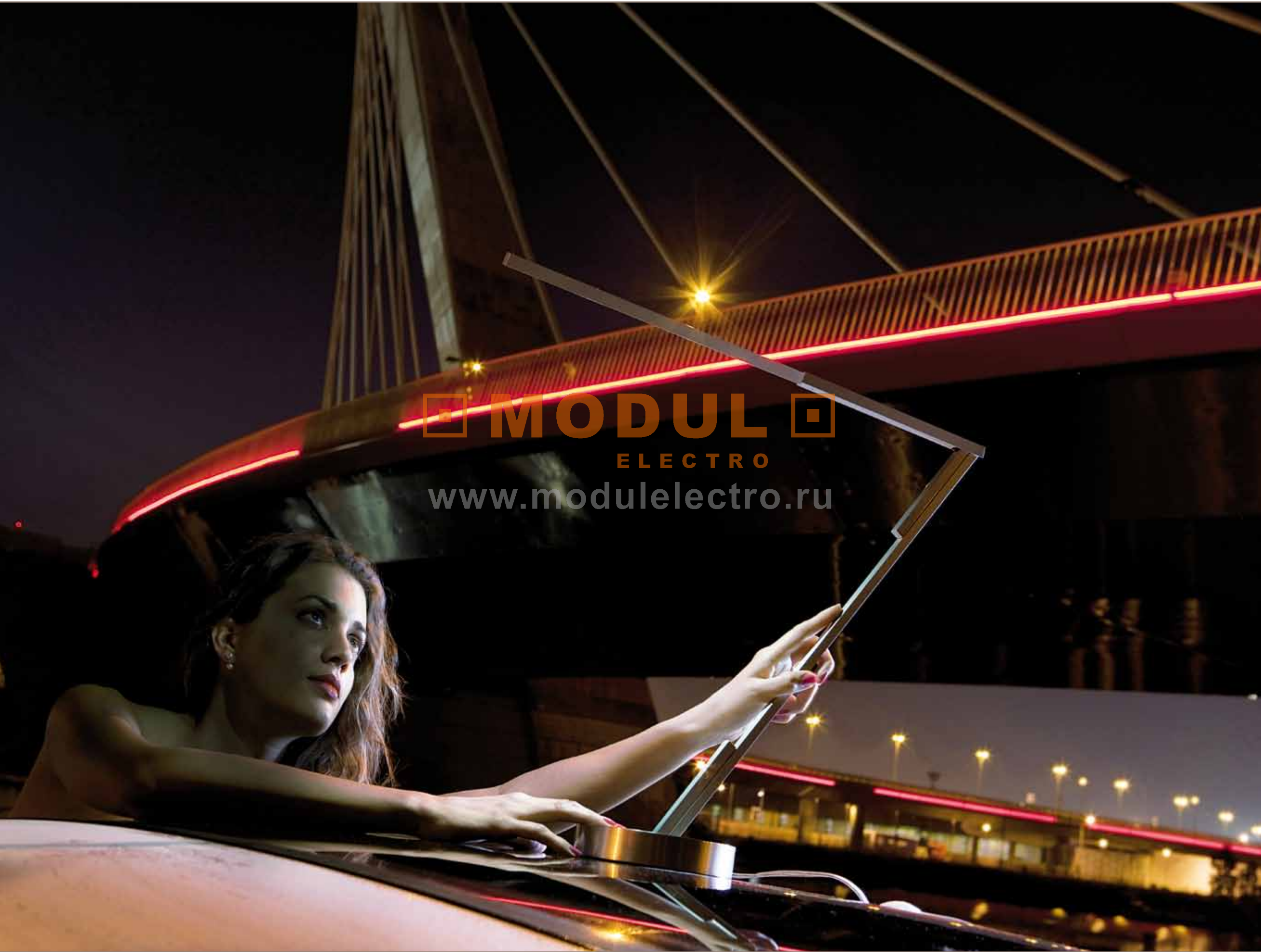

MODUL
ELECTRO
www.modulelectro.ru

Lampada da tavolo ad emissione di luce diretta. Struttura in metallo cromato, con particolari in alluminio spazzolato. Diffusore in vetro soffiato cristallo. La fonte luminosa può essere direzionata dall'esterno tramite una calamita posta sulla sommità del diffusore.

Table lamp for direct lighting. Chromed metal frame with brushed aluminium accents. Crystal hand-blown glass diffuser. The light source can be adjusted from the outside through a magnet placed on the diffuser top.

Lampe de bureau qui répand une clarté directe. Structure en métal chromé, avec des détails en aluminium brossé. Diffuseur en verre Crystal soufflé. La source lumineuse peut être dirigée de l'extérieur par un aimant placé sur le sommet du diffuseur.

Tischleuchte mit direkter Lichtverteilung. Gestell aus verchromtem Metall, mit Metallteilen aus gebürstetem Aluminium. Glasschirm aus mundgeblasenem Kristallglas. Die Orientierung des Lichtstrahls wird durch einen Magnet am oberen Ende der Leuchte geregelt.

Lámpara de mesa a emisión de luz directa. Estructura en metal cromado, con particulares en aluminio cepillado. Difusor en vidrio soplado cristal. La fuente luminosa puede ser direccionada del exterior por medio de un imán puesto en el cumbre del difusor.

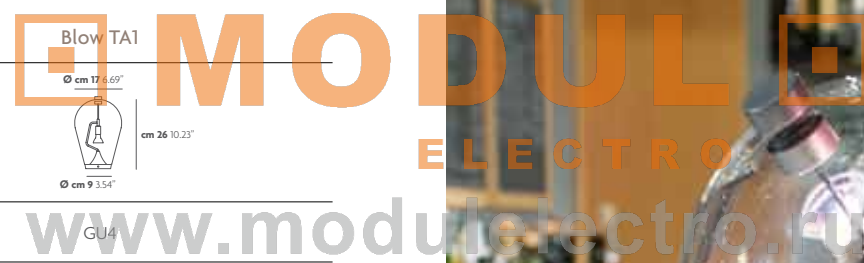

nome name	Blow TA1	
portalampana lamp socket	GU4	GU4
potenza max max wattage	1x35w	1x35w
simbolo symbol		
diffusore diffuser	000	000
montatura frame	Cr	Cr
certificazioni certifications		
IP	20	20
alimentatore gear	Electronico incluso Elect. incl.	Electronico incluso Elect. incl.
For USA and CANADA		
lamp socket	GU4	GU4
max wattage	1x35w	1x35w
symbol		
Fixture supplied with backplate	NO	NO
Mounts to standard 4" junction box	NO	NO
certifications	—	—
gear	Elect. incl.	Elect. incl.

BUBBLE

DESIGN: S.I.D., 1950-1982

BUBBLE

Project Private villa
Location Verona, Italy

Photographer Andrea Pancino

Lampada da tavolo ad emissione di luce diffusa. Struttura in metallo nickel satinato. Diffusore in vetro soffiato bianco satinato. Cablaggio con dimmer.

Table lamp for diffused lighting. Satin nickel metal frame. White satin hand blown glass diffuser. Wiring with dimmer.

Lampe de bureau qui répand une clarté diffuse. Structure en métal nickel-satiné. Diffuseur en verre blanc soufflé satiné. Cable d'alimentation avec variateur.

Tischleuchte mit gestreuter Lichtverteilung. Metallgestell aus satiniertem Nickel. Glasschirm aus weissem, satiniertem, mundgeblasenem Opalglas. Mit Dimmer ausgestattet.

Lámpara de mesa a emisión de luz difusa. Estructura en metal níquel satinado. Difusor en vidrio soplado blanco opalino satinado. Equipada con regulador de intensidad.



nome name	Bubble TA3
portalampana lamp socket	G9
potenza max max wattage	2x60w
simbolo symbol	
diffusore diffuser	030
montatura frame	Nt
certificazioni certifications	0,5m CE V PC
IP	20
alimentatore gear	Non richiesto Not required
For USA and CANADA	
lamp socket	G9
max wattage	2x60w
symbol	
Fixture supplied with backplate	NO
Mounts to standard 4" junction box	NO
certifications	—
gear	Not required



Suspension

Pg. 46



Wall lamp

Pg. 156



Ceiling lamp

Pg. 156



Floor lamps

Pg. 328



Lampada da tavolo ad emissione di luce diffusa. Diffusore in vetro soffiato bianco satinato. Struttura in metallo disponibile nella finitura galvanica cromo e verniciata bianca. Ideale per il comodino, dotata di un interruttore a raggi infrarossi. E' possibile spegnere la luce posando il libro sulla base, ottenendo così un effetto segnalibro. Buonanotte!

Table lamp for diffused lighting. White satin hand blown glass diffuser. Metal frame available in chrome galvanic finishing and lacquered white. Ideal as bedside lamp, equipped with a infrared switch. By resting a book on the base, the light switches off giving a "bookmark effect". Buonanotte (Goodnight)!

Lampe de table à éclairage diffus. Diffuseur en verre blanc satiné soufflé. Structure en métal disponible dans la finition galvanique chromé et verni blanche. Idéal pour la table de nuit, doté d'un interrupteur à infrarouge. En posant un livre sur la monture est possible éteindre la lumière en obtenant un effet marque-page. Buonanotte (Bonne nuit)!

Tischleuchte mit gestreuter Lichtverteilung. Gestell aus verchromtem Metall oder weiss lackiert. Glasschirm aus weissem mundgeblasenem Opalglas. Besonders für den Nachttisch geeignet, ist mit Infrarotschalter ausgestattet, wird einfach durch Hinlegen eines Buches über dem Gestell ausgeschaltet, so dass man die Leuchte auch als Lesezeichen benutzt. Buonanotte (Gute Nacht)!

Lámpara de mesa a emisión de luz difusa. Difusor en vidrio soplado blanco opalino. Estructura en metal cromado o barnizado blanco. Ideal por la mesilla, dotado de interruptor electrónico a infrarrojos, se apaga la luz poniendo un libro en la estructura, esto sirve también como marcador. Buonanotte (Buenas noches)!

MODULO
ELECTRO
www.modulelectro.ru

Buonanotte TA

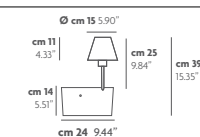

portalampada lamp socket	E14
potenza max max wattage	1x60w
simbolo symbol	
diffusore diffuser	016
montatura frame	Cr Bk
certificazioni certifications	0,5 m
IP	20
alimentatore gear	Non richiesto Not required
For USA and CANADA	
lamp socket	Available only in EU version
max wattage	Available only in EU version
symbol	Available only in EU version
Fixture supplied with backplate	Available only in EU version
Mounts to standard 4" junction box	Available only in EU version
certifications	Available only in EU version
gear	Available only in EU version





Lampada da tavolo ad emissione di luce diffusa. Struttura in metallo nickel satinato .Diffusore in vetro soffiato opalino "plisse" disponibile nei colori: bianco satinato, rosso lucido e ambra satinato.

Table standing luminaire for diffuse lighting. Satin nickel metal frame. Diffuser in pleated hand blown glass, available in the following colours: white satin, red polished and amber polished.

Lampe de bureau qui répand une clarté diffuse. Structure en métal nickel satiné. Diffuseur en verre soufflé opalin « plissé » disponible dans les couleurs: blanc satiné, rouge poli et ambre poli.

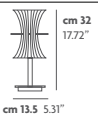
Tischleuchte mit gestreuter Lichtverteilung. Metallgestell aus satiniertem Nickel. Der Glasschirm ist aus "plissiertem", mundgeblasenem Glas, und erhältlich in den Farben: Weiß, satinierten Amber oder Rotglänzend.

Lámpara de mesa a emisión de luz difusa. Estructura en metal níquel satinado. Difusor en vidrio soplado opalino "plisado" disponible en los colores: blanco, ámbar satinado o rojo lustroso.

nome name	Clessidra TA1
	
portalampada lamp socket	G9
potenza max max wattage	2X40w
simbolo symbol	
diffusore diffuser	
montatura frame	Nt
certificazioni certifications	  
IP	20
alimentatore gear	Non richiesto Not required
For USA	
lamp socket	G9
max wattage	2X40w
symbol	
Fixture supplied with backplate	NO
Mounts to standard 4" junction box	NO
certifications	—
gear	Not required



Suspension

Pg. 50



Wall lamp

Pg. 158



Ceiling lamp

Pg. 158

MODULO
ELECTRO
www.modulelectro.ru



CURL MY LIGHT

DESIGN: DIMA LOGINOFF, 2010

CURL MY LIGHT

Private Shiraz lounge bar
Location Treviso, Italy

Photographer Andrea Pancino

Lampada da tavolo ad emissione di luce diffusa. Struttura e diffusore in metallo a sezioni circolari disponibile nei colori bianco (con cablaggio in tessuto nero) e nero (con cablaggio in tessuto bianco).

Table lamp for diffused lighting. Round sectional metal frame and diffuser, available in white (with black fabric cable) and black (with white fabric cable).

Lampe de bureau émettant une clarté diffuse. Structure en métal à sections circulaires disponible dans les couleurs blanc (avec le câble en tissu noir) et noir (avec le câble en tissu blanc).

Tischleuchte mit gestreuter Lichtverteilung. Gestell aus weiß (mit schwarze Stoffverkabelung)- oder schwarzlackiertem (mit weisse Stoffverkabelung) Metall.

Lámpara de mesa a emisión de luz difusa. Estructura en metal a secciones circulares disponible en blanco (con cableado en tejido negro) o negro (con cableado en tejido blanco).

nome
name

Curl my light TA

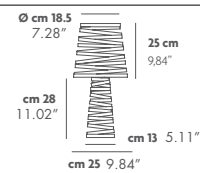

portalampana lamp socket	E27
potenza max max wattage	1x100w
simbolo symbol	
diffusore diffuser	-
montatura frame	<input type="checkbox"/> Bk <input type="checkbox"/> Nr
certificazioni certifications	
IP	20
alimentatore gear	Non richiesto Not required

For USA
and CANADA

lamp socket	E26
max wattage	1x100w
symbol	
Fixture supplied with backplate	NO
Mounts to standard 4" junction box	NO
certifications	
gear	Not required



Suspension

Pg. 54



Floor lamp

Pg. 330

MODULO
ELECTRO
www.modulelectro.ru



Lampada da tavolo ad emissione di luce diretta orientabile. Struttura in metallo nickel satinato.

Table lamp for direct adjustable lighting. Satin nickel metal frame.

Lampe de bureau qui répand une clarté directe orientable. Structure en métal nickel satiné.

Tischleuchte mit direkter, einstellbarer Lichtverteilung. Metallgestell aus satiniertem Nickel.

Lámpara de mesa a emisión de luz directa orientable. Estructura en metal níquel satinado.

nome name	Edo TA
portalampada lamp socket	W4,3
potenza max max wattage	1x13w
simbolo symbol	
diffusore diffuser	-
montatura frame	Nt
certificazioni certifications	
IP	20
alimentatore gear	Elettronico incluso Elect. incl.
For USA and CANADA	
lamp socket	W4,3
max wattage	1x13w
symbol	
Fixture supplied with backplate	NO
Mounts to standard 4" junction box	NO
certifications	
gear	Elect. incl.

MODULO
ELECTRO
www.modulelectro.ru





Lampada da tavolo ad emissione di luce diretta. Struttura snodabile in metallo cromato. Diffusore orientabile in alluminio spazzolato.

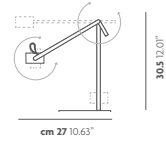

Table lamp for direct lighting. Adjustable chromed metal frame. Adjustable brushed aluminium diffuser.

Lampe de bureau qui répand une clarté directe. Structure adaptable en métal chromé. Diffuseur orientable en aluminium brossé.

Tischleuchte mit direkter Lichtverteilung. Verstellbares Gestell aus verchromtem Metall. Verstellbarer Schirm aus gebürstetem Aluminium.

Lámpara de mesa a emisión de luz directa. Estructura articulable en metal cromado. Difusor orientable en aluminio cepillado.

MODULO
ELECTRO
www.modulelectro.ru

nome name	Giò
	
portalampana lamp socket	Led Optospot
potenza max max wattage	1x4,2w LED
simbolo symbol	
diffusore diffuser	—
montatura frame	Cr
certificazioni certifications	
IP	20
alimentatore gear	Elettronico incluso Elect. incl.
For USA and CANADA	
lamp socket	Available only in EU version
max wattage	Available only in EU version
symbol	Available only in EU version
Fixture supplied with backplate	Available only in EU version
Mounts to standard 4" junction box	Available only in EU version
certifications	Available only in EU version
gear	Available only in EU version







Lampada da tavolo ad emissione di luce diffusa. Struttura in alluminio spazzolato con particolari cromati. Diffusore in vetro soffiato bianco satinato. Cablaggio con dimmer.

Table lamp for diffused lighting. Brushed aluminium frame with chromed accents. White satin handblown glass diffuser. Wiring with dimmer.

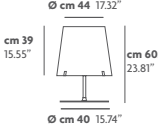
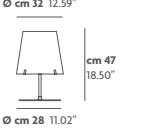
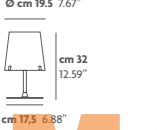





Lampe de bureau qui répand une clarté diffuse. Structure en aluminium brossé avec des détails chromés. Diffuseur en verre blanc satiné soufflé. Câble d'alimentation avec variateur.

Tischleuchte mit gestreuter Lichtverteilung. Gestell aus gebürstetem Aluminium und mit verchromten Metallteilen. Schirm aus satiniertem, mundgeblasenem Opalglas. Mit Dimmer ausgestattet.

Lámpara de mesa a emisión de luz difusa. Estructura en aluminio cepillado y barnizado con particulares cromados. Difusor en vidrio soplado opalino satinado. Equipada con regulador de intensidad.

nome name	Laila TA2	Laila TA	Laila TA1
			
portalampana lamp socket	E27	E27	E27
potenza max max wattage	1x100w	1x100w	1x100w
simbolo symbol			
diffusore diffuser	030	030	030
montatura frame	As	As	As
certificazioni certifications			
IP	20	20	20
alimentatore gear	Non richiesto Not required	Non richiesto Not required	Non richiesto Not required

For USA
and CANADA

lamp socket	E26	E26	E26
max wattage	1x100w	1x100w	1x100w
symbol			
Fixture supplied with backplate	NO	NO	NO
Mounts to standard 4" junction box	NO	NO	NO
certifications			
gear	Not required	Not required	Not required



Floor lamp

Pg. 336

MODULO
ELECTRO
www.modulelectro.ru









Lampada da tavolo ad emissione di luce diffusa. Struttura in metallo nickel satinato. Diffusore in vetro soffiato bianco satinato. Cablaggio con dimmer.

Table lamp for diffused lighting. Nickel satin metal frame. White satin hand blown glass diffuser. Wiring with dimmer.

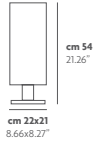
Lampe de bureau qui répand une clarté diffuse. Diffuseur en verre soufflé blanc satiné. Câble d'alimentation avec variateur.

Tischleuchte mit gestreuter Lichtverteilung. Metallgestell aus satiniertem Nickel. Schirm aus satiniertem, weissem, mundgeblasenem Glas. Mit Dimmer ausgestattet.

Lámpara de mesa a emisión de luz difusa. Estructura en metal níquel satinado. Difusor en vidrio soplado blanco satinado. Equipada con regulador de intensidad.

nome name	Mabel TA
	
portalampana lamp socket	E27
potenza max max wattage	2X100w
simbolo symbol	
diffusore diffuser	
montatura frame	
certificazioni certifications	
IP	20
alimentatore gear	Non richiesto Not required
For USA and CANADA	
lamp socket	E26
max wattage	2x40w
symbol	
Fixture supplied with backplate	NO
Mounts to standard 4" junction box	NO
certifications	
gear	Not required



Wall lamp

Pg. 196

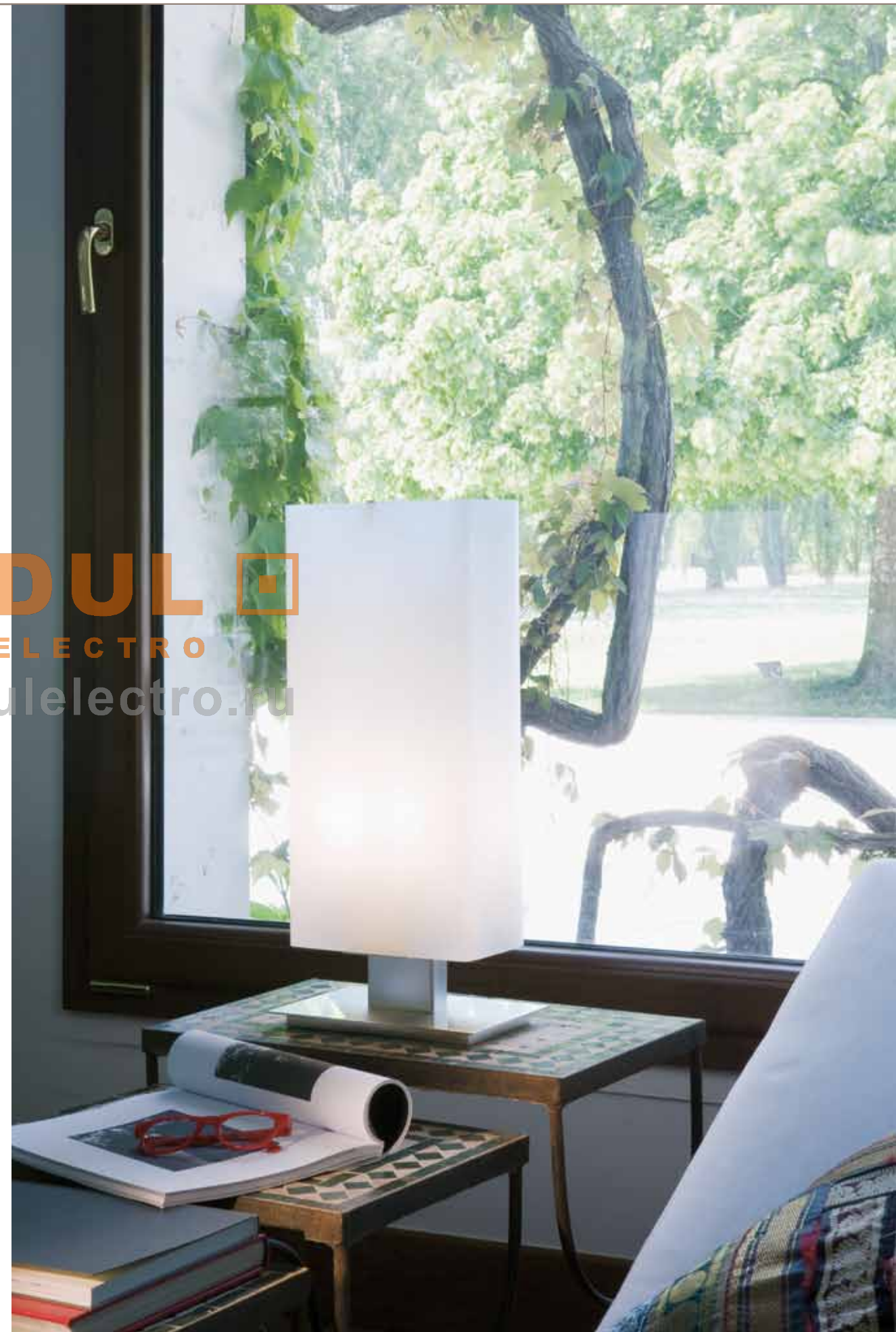

MODULO
ELECTRO
www.modulelectro.ru



Lampada da tavolo ad emissione di luce diretta. La struttura e la e testa sono orientabili grazie ad un innovativo sistema di equilibratura a magneti che permette un movimento fluido e preciso. La struttura è in alluminio spazzolato.

Table lamp for direct lighting. The frame has adjustable head and arms thanks to a cutting-edge magnetic balancing system, giving a flowing and precise motion. Brushed Aluminium frame.

Lampe de bureau qui répand une clarté directe .La structure à les bras et la tête orientables grâce à un système d'équilibrage à aimants innovant, qui permet un mouvement fluide et précis. La structure est en aluminium brossé.

Tischleuchte mit direkter Lichtverteilung. Dank eines Balancing-Magnet- System, ist die stufenlose und präzise Ausrichtung von Lampenarm und Lampenkopf gewährleistet. Die Struktur ist aus gebürstetem Aluminium.

Lámpara de mesa a emisión de luz directa. El movimiento del brazo y del cabezal orientable, se efectúa gracias a un innovador sistema equilibrado por imán que permite un movimiento suave y preciso. La estructura es de aluminio cepillado.

nome
name

MODULO

ELECTRO

www.modulelectro.ru

Magnetita TA

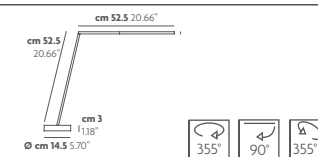

portalampana lamp socket	Citizen Led
potenza max max wattage	2x3w LED
simbolo symbol	
diffusore diffuser	—
montatura frame	As
certificazioni certifications	0,5m CE
IP	20
alimentatore gear	Elettronico incluso Elect. incl.
For USA and CANADA	
lamp socket	Citizen Led
max wattage	2x3w
symbol	
Fixture supplied with backplate	NO
Mounts to standard 4" junction box	NO
gear	Elect. incl.

MINIMANIA

DESIGN: ARCH. ALBERTO GHERARDI, 1998-2002

MINIMANIA

Project Private house
Location Treviso, Italy

Photographer Andrea Pancino







Lampada da tavolo ad emissione di luce diffusa. Struttura in metallo disponibile nelle versioni nickel satinato o cromato. Diffusore in vetro soffiato nei colori bianco satinato, ambra satinato, rosso satinato e marrone lucido.

Table lamp for diffused lighting. Metal frame available in satin nickel or chromed finishing. Hand-blown glass diffuser available in satin white, satin amber, satin red and polished brown colours.

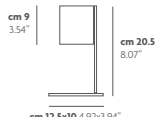
Lampe de bureau qui répand une clarté diffuse. Structure en métal disponible dans les finitions nickel satiné ou chromé. Diffuseur en verre soufflé dans les couleurs blanc satiné, ambre satiné, rouge satiné et marron poli.

Tischleuchte mit gestreuter Lichtverteilung. Das Metallgestell kann aus satiniertem Nickel oder verchromt sein. Der mundgeblasene Glasschirm kann weiss satiniert, amber satiniert, rot satiniert oder braun glänzend sein.

Lámpara de mesa a emisión de luz directa. Estructura en metal disponible en las variantes níquel satinado o cromado. Difusor en vidrio soplado en los colores blanco - ámbar - rojo - satinados o marrón lustroso.

nome name	Minimania TA
	
portalampana lamp socket	G9
potenza max max wattage	1x40w
simbolo symbol	
diffusore diffuser	
montatura frame	
certificazioni certifications	
IP	20
alimentatore gear	Non richiesto Not required
For USA and CANADA	
lamp socket	G9
max wattage	1x40w
symbol	
Fixture supplied with backplate	NO
Mounts to standard 4" junction box	NO
certifications	—
gear	Not required



Wall lamp

Pg. 204

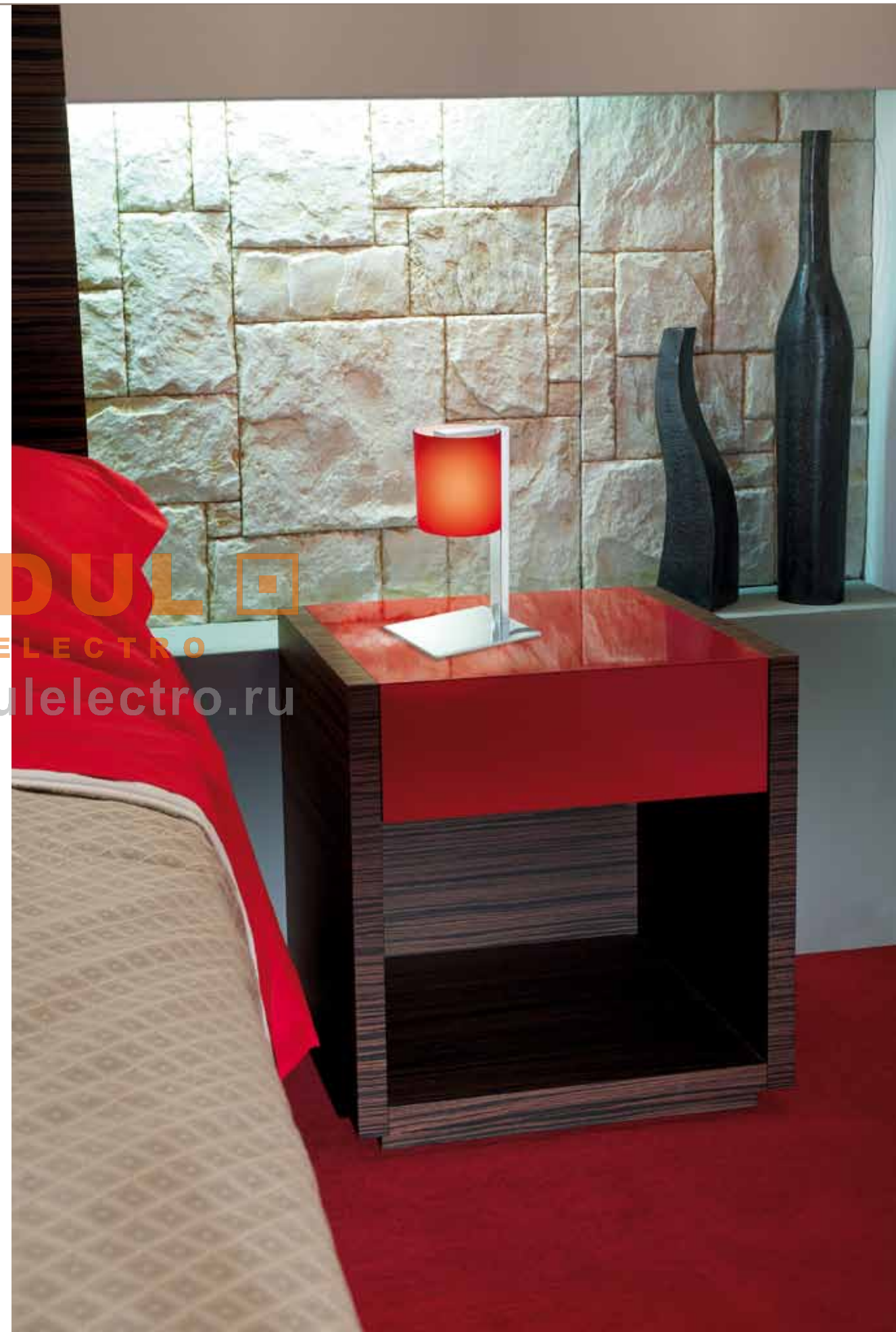

MODULO
ELECTRO
www.modulelectro.ru





Lampada base da appoggio ad emissione di luce diffusa. Diffusore in metacrilato trasparente.

Table lamp for diffused lighting. Acrylic transparent diffuser.

Lampe de bureau qui répand une clarté diffuse. Diffuseur en méthacrylate transparent.

Grundelement mit gestreuter Lichtverteilung. Der Schirm aus Methacrylat ist durchsichtig.

Lámpara a emisión de luz difusa. Difusor en metacrilato transparente.

nome name	Puraluce TA
	 Ø cm 36 14.17"
portalampana lamp socket	2GX13
potenza max max wattage	1x22w
simbolo symbol	
diffusore diffuser	
montatura frame	-
certificazioni certifications	
IP	40
alimentatore gear	Elettronico incluso Elect. incl.
For USA and CANADA	
lamp socket	2GX13
max wattage	1x22w
symbol	
Fixture supplied with backplate	NO
Mounts to standard 4" junction box	NO
certifications	-
gear	Elect. incl.



Suspension

Pg. 98



wall lamp

Pg. 220



Ceiling lamp

Pg. 220

MODULO
ELECTRO
www.modulselectro.ru





MODUL
ELECTRO
www.modulelectro.ru









Lampada da tavolo ad emissione di luce diffusa. Struttura in alluminio spazzolato. Diffusore in vetro soffiato trasparente sostenuto da molle. Cablaggio con dimmer.

Table lamp for diffused lighting. Brushed aluminium frame. Transparent hand-blown glass diffuser supported by springs. Wiring with dimmer.

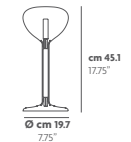
Lampe de bureau qui répand une clarté diffuse. Structure en aluminium brossé. Diffuseur en verre soufflé transparent soutenu par ressorts.

Tischleuchte mit gestreuter Lichtverteilung. Gestell aus gebürstetem Aluminium. Glasschirm aus durchsichtigem mundgeblasenem Kristallglas, wird mit Federn gehalten. Mit Dimmer ausgestattet.

Lámpara de mesa a emisión de luz difusa. Estructura en aluminio. Difusor en vidrio soplado cristal transparente sostenido por muelles. Equipada con regulador de intensidad.

nome name	Soap TA
portalampada lamp socket	 cm 45.1 19.7
potenza max max wattage	G9 1x60w
simbolo symbol	
diffusore diffuser	000
montatura frame	As
certificazioni certifications	0.5m    
IP	20
alimentatore gear	non richiesto not required
For USA and CANADA	
lamp socket	G9
max wattage	1x60w
symbol	
Fixture supplied with backplate	NO
Mounts to standard 4" junction box	NO
certifications	—
gear	not required



Suspension

Pg. 104

Lampada da tavolo ad emissione di luce diffusa. Struttura in metallo cromato. Diffusore in vetro soffiato bianco satinato.

Table lamp for diffused lighting. Chromed metal frame. White hand-blown glass diffuser.

Lampe de bureau qui répand une clarté diffuse. Structure en métal chromé. Diffuseur en verre soufflé blanc satiné

Tischleuchte mit gestreuter Lichtverteilung. Gestell aus verchromtem Metall. Glasschirm aus weissem, satiniertem, mundgeblasenem Glas.

Lámpara de mesa a emisión de luz difusa. Estructura en metal cromado. Difusor en vidrio soplado lanco satinado.

nome
name

Trilogy TA1

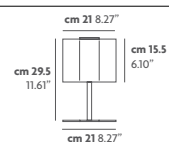

portalampada lamp socket	E14
potenza max max wattage	1x60w
simbolo symbol	
diffusore diffuser	030
montatura frame	Cr
certificazioni certifications	
IP	20
alimentatore gear	Non richiesto Not required
For USA and CANADA	
lamp socket	E12
max wattage	1x25w
symbol	
Fixture supplied with backplate	NO
Mounts to standard 4" junction box	NO
certifications	
gear	Not required



Suspension

Pg. 116



Floor lamp

Pg. 342



MODULO
ELECTRO
www.modulelectro.ru

Floor Lamps | Lampadaire | Stehleuchten | Suelo

 **MODULO**
ELECTRO
www.modulelectro.ru

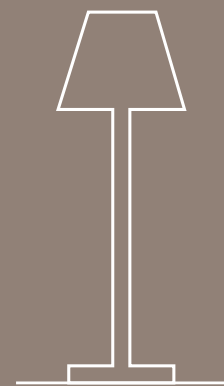

TERRA

Floor Lamps
Lampadaire
Sthleuchten
Suelo



MODULO
ELECTRO
www.modulelectro.ru

Lampada da terra ad emissione di luce indiretta e diretta. Struttura e diffusore in metallo bianco. Cablaggio con dimmer e doppia accensione.

Floor lamp for indirect and direct lighting. White metal frame and diffuser. Wiring equipped with double switch and dimmer.

Lampadaire émettant un éclairage indirect et direct. Structure et diffuseur en métal blanc. Câble d'alimentation équipé avec variateur et double allumage.

Stehleuchte mit indirekter und direkter Lichtverteilung. Das Metallgestell ist weiss lackiert. Doppelt einschaltbar und mit Dimmer ausgestattet.

Lámpara de suelo para iluminación indirecta y directa. Estructura en metal. Equipada con doble interruptor y regulador de intensidad.



nome
name

Andrei LT

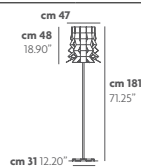

portalampana lamp socket	R7s 118mm + GU10
potenza max max wattage	1x200w + 2X50w
simbolo symbol	 + 
diffusore diffuser	Bk
montatura frame	Bk
certificazioni certifications	0,5m   
IP	20
alimentatore gear	Non richiesto Not required
For USA and CANADA	
lamp socket	R7s long + GU10
max wattage	1x200w + 2X50w
symbol	 + 
Fixture supplied with backplate	NO
Mounts to standard 4" junction box	NO
certifications	—
gear	Not required



Suspension

Pg. 34



Wall lamp

Pg. 152

MODULO
ELECTRO
www.modulelectro.ru

BUBBLE

DESIGN: S.I.D., 1950-1982

BUBBLE

Project Villa Irene
Location Casale sul Sile, Italy

Photographer Andrea Pancino

Lampada da terra ad emissione di luce diffusa. Struttura in metallo nickel satinato. Diffusore in vetro soffiato bianco satinato. Cablaggio con dimmer.

Floor lamp for diffused lighting. Satin nickel metal frame. White satin blown glass diffuser. Wiring with dimmer.

Lampadaire émettant un éclairage diffus. Structure en métal nickel satiné. Diffuseur en verre blanc soufflé. Câble d'alimentation avec variateur.

Stehleuchte mit gestreuter Lichtverteilung. Metallgestell aus satiniertem Nickel. Schirm aus weissem, satiniertem mundgeblasenem Opalglas. Mit Dimmer ausgestattet.

Lámpara a emisión de luz difusa. Estructura en metal níquel satinado. Difusor en vidrio soplado blanco opalino satinado. Equipada con regulador de intensidad.



nome
name

Bubble LT

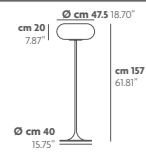

portalampana lamp socket	G9
potenza max max wattage	3x75w
simbolo symbol	
diffusore diffuser	030
montatura frame	Nt
certificazioni certifications	
IP	20
alimentatore gear	Non richiesto Not required

For USA and CANADA	
lamp socket	G9
max wattage	3x75w
symbol	
Fixture supplied with backplate	NO
Mounts to standard 4" junction box	NO
certifications	—
gear	Not required



MODULO
ELECTRO
www.modulelectro.ru



Lampada da terra ad emissione di luce diffusa. Struttura e diffusore in metallo a sezioni circolari disponibile nei colori bianco (con cablaggio in tessuto nero) e nero (con cablaggio in tessuto bianco).

Floor lamp for diffused lighting. Round sectional metal frame and diffuser, available in white (with black fabric cable) and black (with white fabric cable).

Lampadaire émettant une clarté diffuse. Structure et diffuseur en métal à sections circulaires, disponible dans les couleurs blanc (avec le câble en tissu noir) et noir (avec le câble en tissu blanc).

Stehleuchte mit gestreuter Lichtverteilung. Gestell aus weiß (mit schwarze Stoffverkabelung)-oder schwarzlackiertem (mit weisse Stoffverkabelung) Metall.

Lámpara de suelo a emisión de luz difusa. Estructura en metal a secciones circulares disponible en blanco (con cableado en tejido negro) o negro (con cableado en tejido blanco).

nome
name

Curl my light LT

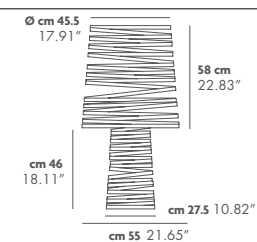

portalampada
lamp socket

E27

potenza max
max wattage

1x100w

simbolo
symbol



diffusore
diffuser

—

montatura
frame

Bk Nr

certificazioni
certifications



IP

20

alimentatore
gear

Non richiesto
Not required

**For USA
and CANADA**

lamp socket

E26

max wattage

1x100w

symbol



Fixture
supplied with
backplate

NO

Mounts to
standard 4"
junction box

NO

certifications



gear

Not required



Suspension

Pg. 54



Table lamp

Pg. 300

CURL MY LIGHT

CURL MY LIGHT

Project Shiraz lounge bar
Location Treviso, Italy

Photographer Andrea Pancino



MODULO
ELECTRO
www.modulelectro.ru







Lampada da terra ad emissione di luce indiretta. Struttura in acciaio spazzolato con particolare in cromo. Cablaggio con dimmer.

Floor lamp for indirect lighting. Brushed stainless steel frame with chrome accent. Wiring with dimmer.

Lampadaire qui répand une clarté indirecte. Structure en acier brossé avec détail en chrome. Câble d'alimentation avec variateur.

Stehleuchte mit indirekter Lichtverteilung. Gestell aus gebürstetem Edelstahl. Schirm aus verchromtem Metall. Mit Dimmer ausgestattet.

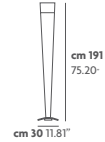
Lámpara de suelo a emisión de luz indirecta. Estructura en acero cepillado. Difusor en metal cromado. Equipada con regulador de intensidad.

nome name	Escudo LT
	
portalampada lamp socket	R7s 118mm
potenza max max wattage	1x200w
simbolo symbol	
diffusore diffuser	Cr
montatura frame	Sp
certificazioni certifications	0,5m CE V PC
IP	20
alimentatore gear	Non richiesto Not required
For USA and CANADA	
lamp socket	R7s long
max wattage	1x100w
symbol	
Fixture supplied with backplate	NO
Mounts to standard 4" junction box	NO
certifications	—
gear	Not required

Lampada da terra ad emissione di luce diffusa. Struttura in alluminio spazzolato e con particolari cromati. Diffusore in vetro soffiato bianco satinato. Cablaggio con dimmer.

Floor lamp for diffused lighting. Satin nickel metal frame with chrome accents. White satin blown glass diffuser. Wiring with dimmer.

Lampadaire émettant un éclairage diffus. Structure en métal nickel satiné avec détails en chrome. Diffuseur en verre blanc soufflé. Câble d'alimentation avec variateur.

Stehleuchte mit gestreuter Lichtverteilung. Gestell aus gebürstetem Aluminium mit verchromten Metallteilen. Schirm aus satiniertem, mundgeblasenem Opalglas. Mit Dimmer ausgestattet.

Lámpara de mesa a emisión de luz difusa. Estructura en aluminio cepillado y barnizado con particulares cromados. Difusor en vidrio soplado opalino satinado. Equipada con regulador de intensidad.

nome
name

LAILA LT

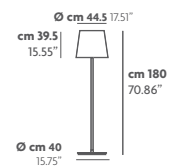

portalampana lamp socket	E27
potenza max max wattage	1x100w
simbolo symbol	
diffusore diffuser	030
montatura frame	As
certificazioni certifications	0,5 m CE V PC
IP	20
alimentatore gear	Non richiesto Not required
For USA and CANADA	
lamp socket	A19
max wattage	1x100w
symbol	
Fixture supplied with backplate	NO
Mounts to standard 4" junction box	NO
certifications	
gear	Not required



Table lamp

Pg. 306

MODULO
ELECTRO
www.moduloelectro.ru



Lampada da terra ad emissione di luce diretta. Struttura in alluminio spazzolato con particolari cromati. Diffusore in vetro extra chiaro sabbiato. Struttura con dimmer.

Floor lamp for direct lighting. Brushed aluminium frame with chrome accents. Sanded extra clear glass diffuser. Wiring with dimmer.

Lampadaire qui répand une clarté directe. Structure en aluminium brossé avec des détails chromés. Diffuseur en verre extra clair sablé. Câble d'alimentation avec variateur.

Stehleuchte mit direkter Lichtverteilung. Gestell aus gebürstetem Aluminium mit verchromten Metallteilen. Schirm aus sandgestrahltem Glas. Eingebautes Dimmer.

Lámpara de suelo a emisión de luz difusa. Estructura en aluminio cepillado con particulares en cromo. Difusor en vidrio arenado. Regulador de intensidad incorporado en la estructura.

nome name	Laser LTI
portalampada lamp socket	G5
potenza max max wattage	1x80w
simbolo symbol	
diffusore diffuser	038
montatura frame	As
certificazioni certifications	
IP	20
alimentatore gear	Elettronico dimm. incluso Elect. dimm. incl.
For USA and CANADA	
lamp socket	G5
max wattage	1x80w
symbol	
Fixture supplied with backplate	NO
Mounts to standard 4" junction box	NO
certifications	
gear	Elect. dimm. incl.



Suspension

Pg. 74



Wall lamp

Pg. 184



MODULO
ELECTRO
www.modulelectro.ru



Lampada da terra ad emissione di luce indiretta superiore e diretta frontale. Struttura in metallo bianco. Cablaggio con doppio dimmer.





Floor lamp for indirect up lighting and diffused front lighting. White metal frame. Double dimmer wiring.

Lampadaire émettant un éclairage indirect en haute et direct en face. Structure en métal blanc. Câble d'alimentation avec double variateur.

Stehleuchte mit gestreuter und indirekter Lichtverteilung. Das Metallgestell ist weiss lackiert. Doppelt einschaltbar. Ausgestattet mit einem eingebautem Dimmer und einem Kabeldimmer.

Lámpara de suelo para iluminación indirecta y difusa. Estructura en metal o blanco en bronce, balasto electrónico dimmerable incluido. Equipada con doble interruptor y doble regulador de intensidad.

MODULO
ELECTRO
www.modulelectro.ru

nome name	Menir LT
portalampada lamp socket	G5 + R7s 118mm
potenza max max wattage	2x80w + 1x200w
simbolo symbol	
diffusore diffuser	038
montatura frame	Bk
certificazioni certifications	0,5m CE  
IP	20
alimentatore gear	Elettronico dimm. incluso Elect. dimm. incl.
For USA and CANADA	
lamp socket	G5 R7s
max wattage	2x80w 1x200w
symbol	
Fixture supplied with backplate	NO
Mounts to standard 4" junction box	NO
certifications	-
gear	Elect. dimm. incl.

Lampada da terra ad emissione di luce diffusa. Struttura in metallo cromato. Diffusore in vetro soffiato bianco satinato. Cablaggio con dimmer.

Floor lamp for diffused lighting. Chromed metal frame. White satin blown glass diffuser. Wiring with dimmer.

Lampadaire qui répand une clarté diffuse. Structure en métal chromé. Diffuseur en verre soufflé blanc satiné. Câble d'alimentation avec variateur.

Stehleuchte mit gestreuter Lichtverteilung. Gestell aus verchromtem Metall. Glasschirm aus weissem, mundgeblasenem, satiniertem Glas. Mit Dimmer ausgestattet.

Lámpara de suelo a emisión de luz difusa. Estructura en metal cromado. Difusor en vidrio soplado blanco satinado. Equipada con regulador de intensidad.

nome
name

Trilogy LT

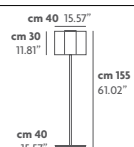

portalampada lamp socket	E27
potenza max max wattage	1x150w
simbolo symbol	
diffusore diffuser	030
montatura frame	Cr
certificazioni certifications	0,5 m
IP	20
alimentatore gear	Non richiesto Not required
For USA and CANADA	
lamp socket	R7s
max wattage	2x75w
symbol	
Fixture supplied with backplate	NO
Mounts to standard 4" junction box	NO
certifications	
gear	Not required



Suspension
Pg. 116



Table lamp
Pg. 320



Italiano

Ogni singolo prodotto **Studio Italia Design** è conforme alla marcatura CE richiesta dalla Comunità Europea con la direttiva 93/68 (ampliamento della direttiva 73/23) per confermare con una marcatura riconosciuta in tutta Europa, che le lampade sono state sottoposte alle prove di sicurezza elettrica richieste dalle norme Europee EN-60598-1-2 II ed. + CEI EN 60598-1 IV ed. corrispondenti norme italiane CEI 34-21 + CEI 34-23, norme per la sicurezza elettrica a cui fanno riferimento tutti gli istituti, compreso l'IMQ. I prodotti indicati con il marchio UL e/o ETL sono conformi alla normativa UL 1598/CAN/USA C22.2 No.250.0 o UL 153.

L'azienda, ferme restando le caratteristiche fondamentali degli articoli presentati in catalogo, si riserva di apportare, in qualsiasi momento, le modifiche opportune al miglioramento della qualità.

I prodotti sono garantiti per la durata di un anno e, in caso di difetti, verranno, a discrezione dell'azienda, sostituiti o riparati. Questa copertura decade di validità nel caso di manomissione e di uso o di una installazione non corretti.

English

Every single product of **Studio Italia Design** corresponds to the CE mark laid down by the European Community with Directive 93/68 (extension of Directive 73/23) to confirm, with a mark recognised all over Europe, that the lights have undergone the electrical safety test required by European standards EN-60598-1-2 II ed. + CEI EN 60598-1 IV ed. corresponding to Italian standards CEI 34-21 + CEI 34-23, electrical safety standards referred to by all institutions, including the IMQ. The products indicated with the logo UL and/or ETL corresponds to the standards UL 1598/CAN/USA C22.2 No.250.0 o UL 153.

At any time, Studio Italia Design may introduce the necessary changes to improve the quality of its products, while maintaining the basic features of the articles shown in the catalogue.

Every product has a one-year guarantee. If the products are faulty, they will be replaced or repaired. In case of wrong use or installation the guarantee is not valid.

Français

Chacun des produits **Studio Italia Design** est conforme aux la marque CE imposée par la directive 93/68 (extension de la directive 73/23) établie par la Communauté européenne pour confirmer par une marque reconnue dans toute l'Europe que les lampes ont été soumises aux épreuves de sécurité électrique requises par les normes européennes EN-60598-1-2 II ed. + CEI EN 60598-1 IV ed. correspondant aux normes italiennes CEI 34-21 + CEI 34-23, normes de sécurité électrique auxquelles se réfèrent tous les instituts, y compris l'IMQ. Les produits indiqués avec la marque UL et/ou ETL sont conformes aux normes UL 1598/CAN/USA C22.2 No.250.0 ou UL 153.

L'entreprise, tout en conservant les caractéristiques fondamentales des articles présentés au catalogue, se réserve la possibilité d'apporter à tout moment les modifications opportunes à l'amélioration de la qualité.

Les produits sont garantis un an et, en cas de défauts, ils seront, à discrétion de l'entreprise, remplacés ou réparés.

Cette garantie prend fin en cas de démontage et d'un usage ou d'une installation incorrects.

Deutsch

Jedes einzelne Produkt von **Studio Italia Design** entspricht das CE Prüfzeichen von der Europäischen Gemeinschaft mittels Richtlinie 93/68 (Erweiterung der Richtlinie 73/23) gefordert, um mit einem in ganz Europa anerkannten Prüfzeichen zu bestätigen, daß die Lampen allen von den Europäischen Normen EN-60598-1-2 II ed. + CEI EN 60598-1 IV ed. geforderten Prüfungen hinsichtlich der elektrischen Sicherheit unterzogen wurden, die den italienischen Normen CEI 34-21 + CEI 34-23 entsprechen, d.h. den Normen bezüglich der elektrischen Sicherheit, auf die sich alle Institute, einschließlich der IMQ, beziehen. Wo der UL und/oder ETL Logo erscheinen, entsprechen die Leuchten die UL 1598/CAN/USA C22.2 No.250.0 oder UL 153 Norm.

Unter Beibehaltung der grundsätzlichen Kennzeichen der im Katalog aufgeführten Artikel behält sich der Betrieb vor, zu jeder Zeit Änderungen daran vorzunehmen, die für die Verbesserung der Qualität notwendig sind.

Die Produkte haben ein Jahr Garantie und werden, falls sie Fehler aufweisen sollten, nach Prüfung ersetzt oder repariert. Bei nicht fachmännischer Behandlung, Installation und Gebrauch gilt diese Garantie nicht mehr.

Español

Cada artículo **Studio Italia Design** tiene la marcatura CE en conformidad a la directiva 93/68 (ampliamento de la directiva 73/23) para confirmar que las lamparas han sido sometidos a las pruebas de seguridad eléctrica exigidos de las normativas europeas EN-60598-1-2 II ed. + CEI EN 60598-1 IV ed. equivalentes normas italianas CEI 34-21 + CEI 34-23, normas para la seguridad eléctrica punto de referencia para todos los institutos, incluido IMQ. Los productos que tienen el sello UL y/o ETL tienen la conformidad a las normativas UL 1598/CAN/USA C22.2 No.250.0 o UL 153.

La empresa, mantenido las características fundamentales de los artículos presentados en el catálogo, se reserva el derecho de realizar en cualquier momento cualquier modificación necesaria a sus modelos para mejorar la cualidad.

Los productos tienen la garantía por un año y, en presencia de defectos, vendrán sustituidos o arreglados a discreción de Sid. Esta garantía pierde validez en presencia de un uso o de una instalación no correctos.

STUDIO
ITALIA DESIGN

STUDIO ITALIA DESIGN srl - Via Pialoi, 32 - 30020 Marcon - Venezia - Italy
tel +39 041 4569266 - fax +39 041 4567337
info@studioitaliadesign.com
www.studioitaliadesign.com

thanks to

www.modulelectro.ru

Andrea Pancino
Bellatrix s.r.o.
BPA International
Cataldo Leo
Doimo Salotti
Elisa Dazzan
Enrico Cattelan
Floritelli Cucine
Giovanna e Renato La Osteria
Grafiche Tintoretto
Helios Illuminotecnica
L'Arte di Abitare
LSI Systems (I) Pvt. Ltd.
Mario Chies
Oberoi construction
Studio Dentistico Dott.ri A. Cerutti, S. Fabris, C. Di Chiara.
Studium & Associates, Avv. M. Salvalaio
Studium & Associates, Dott. P. Fontana
Virginia Preo Cashmere

Studio Italia Design si riserva il diritto di apportare ai propri modelli, senza nessun preavviso, qualsiasi modifica ritenesse opportuna.

Studio Italia Design reserves the right to introduce any changes to its own models, without notice in advance.

Studio Italia Design behält sich das recht vor änderungen vorzunehmen, ohne sofortige benachrichtigung.

Studio Italia Design se réserve le droit d'apporter une quelconque modification à les modèles sans préavis.

Studio Italia Design se reserva el derecho de realizar cualquier modificación sobre sus modelos sin previo aviso.

MODUL
ELECTRO
www.modulelectro.ru