

TERZANI. EVERYWHERE, EVERYTHING IS LIGHT.

ELECTRO
www.modulelectro.ru

TERZANI
LA LUCE PENSATA

LA LUCE PENSATA DECLINATA COME LUCE AMBIENTATA. SI APPOGGIA SU UN LETTO, AI BORDI DI UNO SPECCHIO, SORVOLA IL SOFFITTO, PRANZA CON VOI, SI SIEDE SU UNA POLTRONA, INQUADRA UNA PARETE, DELIMITA UNO SPAZIO, SI INARCA, SI TENDE E POI DISTENDE.

LA LUCE PENSATA DOVUNQUE L'ABBIATE IMMAGINATA, ORA ABITA CON VOI.

ONE OF THE MOST VERSATILE LIGHTS, LA LUCE PENSATA ENHANCES ANY SPACE. WHETHER IT IS ILLUMINATING THE DINING ROOM OR PROVIDING COMFORT IN THE LIVING ROOM, LA LUCE PENSATA'S ARCHING FORM IMBUES A SENSE OF RELAXED ELEGANCE. ANYWHERE YOU PLACE IT, LA LUCE PENSATA BECOMES PART OF THE ROOM, FRAMING THE WALL, DELIMITING A SPACE, IT ARCHES, STRETCHES AND RELAXES ANYWHERE.



LA LUCE PENSATA: LIGHT FOR LIVING, WHEREVER YOU NEED IT.

MODULO
ELECTRO
www.modulelectro.ru

TERZANI
LA LUCE PENSATA

EVERYTHING IS LIGHT

ORTEN'ZIA, I SUOI PETALI DI LUCE DISEGNANO
LA STANZA. ORTEN'ZIA, DRAWING ON THE WALL
WITH PETALS OF LIGHT.

 **MODUL** 
ELECTRO
www.modulelectro.ru







MODUL
ELECTRO
www.modulelectro.ru





 **MODUL** 
ELECTRO
www.modulelectro.ru





MODUL
ELECTRO
www.modulelectro.ru

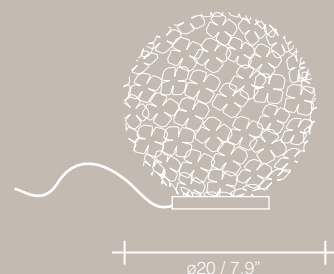
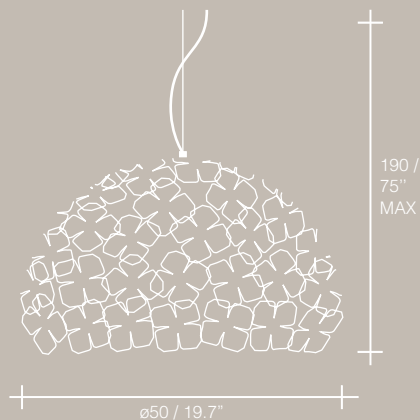

ORTEN'ZIA - DESIGN B. RAINALDI
SOSPENSIONE IN METALLO REALIZZATA SALDANDO A MANO GRAZIOSI PETALI PLACCATI NICHEL O ORO 24K. ORTEN'ZIA SEMISFERA E' PENSATA PER ILLUMINARE PERFETTAMENTE LA SUPERFICIE SOTTOSTANTE CREANDO CONTEMPORANEAMENTE SUGGESTIVI EFFETTI LUMINOSI CHE TRASFORMANO LE PARETI IN UN ROMANTICO GIARDINO DI LUCE.

RECALLING THE NATURAL BEAUTY OF A FLOWER, THIS SUSPENSION LIGHT'S HAND-SOLDERED "PETALS" EMANATE A UNIQUE LIGHT, ILLUMINATING THE SPACE BELOW AND IMMERSING THE ENTIRE ROOM IN A GLIMMERING LIGHT. LIGHT AND SHADOW INTERTWINE TO CREATE AN ORGANIC RADIANCE, DRAWING A GARDEN WITHIN THE ROOM. AVAILABLE IN EITHER NICKEL OR 24K GOLD PLATE. THE ORTEN'ZIA'S ELEGANT FORM COMPLEMENTS ITS DRAMATIC LIGHT.

ORTEN'ZIA - DESIGN B. RAINALDI
SOSPENSIONE SFERICA IN METALLO REALIZZATA SALDANDO A MANO GRAZIOSI PETALI PLACCATI NICHEL O ORO 24K, PER CREARE SUGGESTIVI EFFETTI LUMINOSI CHE IRRADIANO LE PARETI TRASFORMANDELE IN UN ROMANTICO GIARDINO DI LUCE.

RECALLING THE NATURAL BEAUTY OF A FLOWER, THIS SUSPENSION LIGHT'S HAND-SOLDERED "PETALS" EMANATE A UNIQUE LIGHT, IMMERSING THE ENTIRE ROOM IN A GLIMMERING LIGHT. LIGHT AND SHADOW INTERTWINE TO CREATE AN ORGANIC RADIANCE, DRAWING A GARDEN WITHIN THE ROOM. AVAILABLE IN EITHER NICKEL OR 24K GOLD PLATE. THE ORTEN'ZIA'S ELEGANT FORM COMPLEMENTS ITS DRAMATIC LIGHT.

ORTEN'ZIA - DESIGN B. RAINALDI
LAMPADA DA TAVOLO IN METALLO REALIZZATA SALDANDO A MANO GRAZIOSI PETALI PLACCATI NICHEL O ORO 24K, PER CREARE SUGGESTIVI EFFETTI LUMINOSI CHE IRRADIANO L'AMBIENTE TRASFORMANDOLO IN UN ROMANTICO GIARDINO DI LUCE.

RECALLING THE NATURAL BEAUTY OF A FLOWER, THIS TABLE LIGHT'S HAND-SOLDERED "PETALS" EMANATE A UNIQUE LIGHT, IMMERSING THE ENTIRE ROOM IN A GLIMMERING LIGHT. LIGHT AND SHADOW INTERTWINE TO CREATE AN ORGANIC RADIANCE, DRAWING A GARDEN WITHIN THE ROOM. AVAILABLE IN EITHER NICKEL OR 24K GOLD PLATE. THE ORTEN'ZIA'S ELEGANT FORM COMPLEMENTS ITS DRAMATIC LIGHT.

MODUL
ELECTRO

www.modulelectro.ru



PLACCATO NICHEL
NICKEL-PLATED



PLACCATO ORO 24K
24K GOLD-PLATED



PLACCATO NICHEL
NICKEL-PLATED



PLACCATO ORO 24K
24K GOLD-PLATED





PLACCATO NICHEL
NICKEL-PLATED

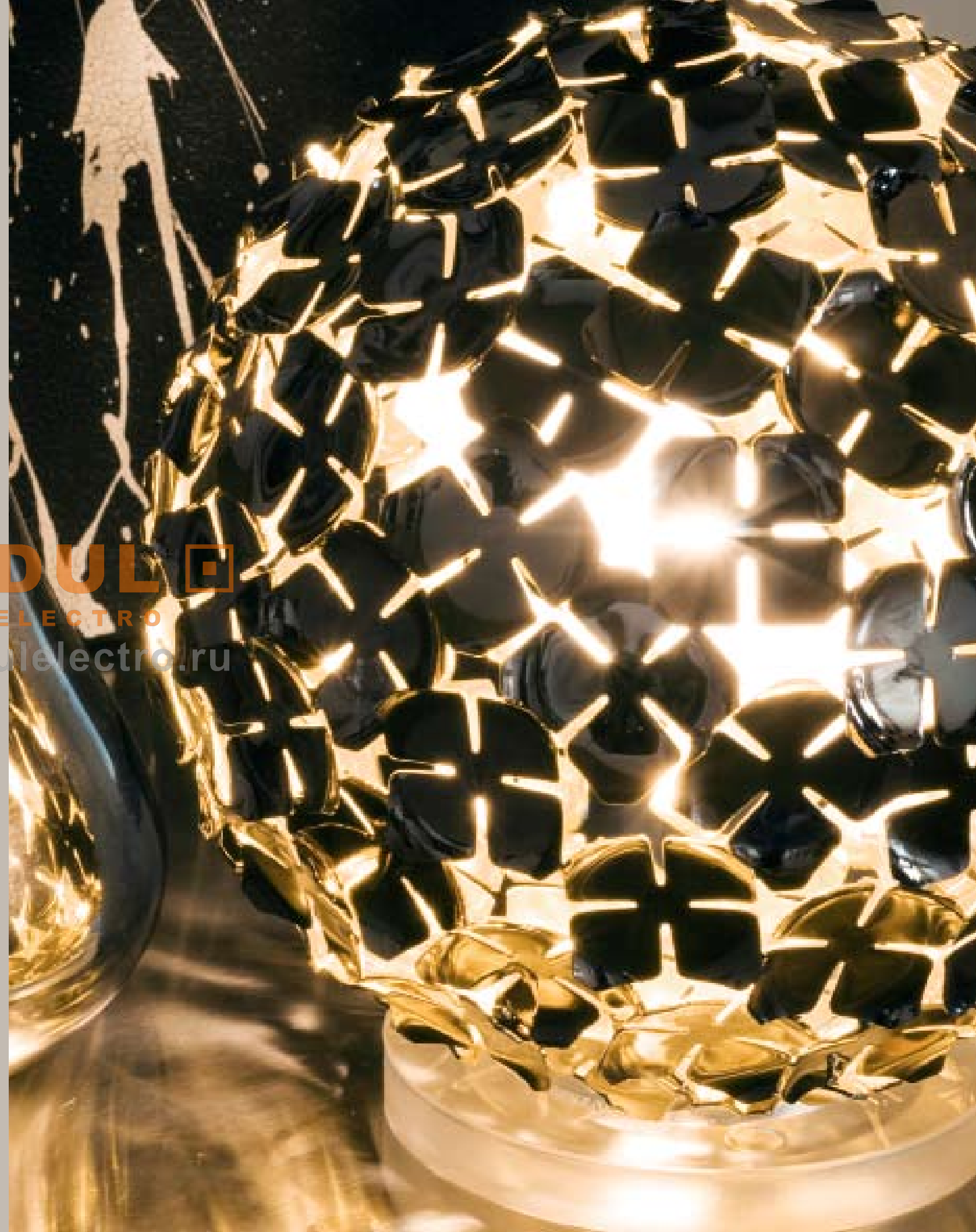

PLACCATO ORO 24K
24K GOLD-PLATED





BOND, INSEGUE, SPIA GEOMETRIE LUMINOSE.
BOND, BANDS OF LIGHT RACING AROUND
GEOMETRIC FORMS.

 **MODUL** 
ELECTRO
www.modulelectro.ru







 **MODUL** 
ELECTRO
www.modulelectro.ru



MODUL
ELECTRO
www.modulelectro.ru



 **MODUL** 
ELECTRO
www.modulelectro.ru



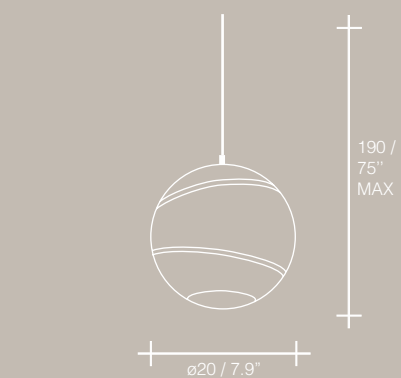
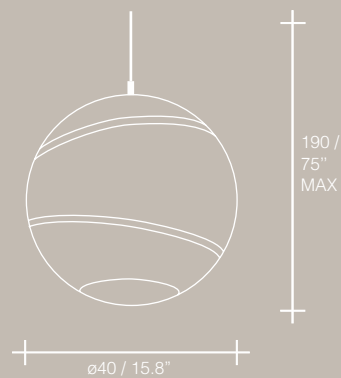

BOND - DESIGN B. RAINALDI
 SFERA IN VETRO SOSPESA, DECORATA INTERNA-
 MENTE DA UNA RICCA APPLICAZIONE FOGLIA
 ORO IN CONTRASTO CON LA NITIDEZZA DELLA
 PARTE ESTERNA IN BIANCO O NERO. LA LUCE
 ATTRAVERSA LE TRASPARENZE DELLA SFERA E IL-
 LUMINA UNIFORMEMENTE L'AMBIENTE CREANDO
 SUGGESTIVI TAGLI LUMINOSI, COME METEORE
 NELLA STANZA.

DISPONIBILE ANCHE NELLA VERSIONE DA APPOG-
 GIO, CON BASE CROMATA.

THIS GLASS SPHERE'S GLOSSY OUTER SHELL
 BELIES THE DELICATE GOLD LEAF APPLIQUÉ
 DECORATING ITS INNER SURFACE. WHEN LIT,
 THE TRANSPARENT OPENING ALLOWS LIGHT TO
 STREAK ACROSS THE SPACE, CREATING TRAILS
 OF LIGHT, LIKE METEORS RACING ACROSS THE
 SKY. AVAILABLE IN WHITE OR BLACK, BOND ALSO
 COMES AS A TABLE LAMP WITH A CHROME-
 PLATED BASE.

BOND - DESIGN B. RAINALDI
 SFERA IN VETRO SOSPESA, DECORATA INTERNA-
 MENTE DA UNA RICCA APPLICAZIONE FOGLIA
 ORO IN CONTRASTO CON LA NITIDEZZA DELLA
 PARTE ESTERNA IN BIANCO O NERO. LA LUCE
 ATTRAVERSA LE TRASPARENZE DELLA SFERA E IL-
 LUMINA UNIFORMEMENTE L'AMBIENTE CREANDO
 SUGGESTIVI TAGLI LUMINOSI, COME METEORE
 NELLA STANZA.

DISPONIBILE ANCHE NELLA VERSIONE DA APPOG-
 GIO, CON BASE CROMATA.

THIS GLASS SPHERE'S GLOSSY OUTER SHELL
 BELIES THE DELICATE GOLD LEAF APPLIQUÉ
 DECORATING ITS INNER SURFACE. WHEN LIT,
 THE TRANSPARENT OPENING ALLOWS LIGHT TO
 STREAK ACROSS THE SPACE, CREATING TRAILS
 OF LIGHT, LIKE METEORS RACING ACROSS THE
 SKY. AVAILABLE IN WHITE OR BLACK, BOND ALSO
 COMES AS A TABLE LAMP WITH A CHROME-
 PLATED BASE.

BOND - DESIGN B. RAINALDI
 SFERA IN VETRO SOSPESA, DECORATA INTERNA-
 MENTE DA UNA RICCA APPLICAZIONE FOGLIA
 ORO IN CONTRASTO CON LA NITIDEZZA DELLA
 PARTE ESTERNA IN BIANCO O NERO. LA LUCE
 ATTRAVERSA LE TRASPARENZE DELLA SFERA E IL-
 LUMINA UNIFORMEMENTE L'AMBIENTE CREANDO
 SUGGESTIVI TAGLI LUMINOSI, COME METEORE
 NELLA STANZA.

DISPONIBILE ANCHE NELLA VERSIONE DA APPOG-
 GIO, CON BASE CROMATA.

THIS GLASS SPHERE'S GLOSSY OUTER SHELL
 BELIES THE DELICATE GOLD LEAF APPLIQUÉ
 DECORATING ITS INNER SURFACE. WHEN LIT,
 THE TRANSPARENT OPENING ALLOWS LIGHT TO
 STREAK ACROSS THE SPACE, CREATING TRAILS
 OF LIGHT, LIKE METEORS RACING ACROSS THE
 SKY. AVAILABLE IN WHITE OR BLACK, BOND ALSO
 COMES AS A TABLE LAMP WITH A CHROME-
 PLATED BASE.

MODUL
 ELECTRO
www.modulelectro.ru

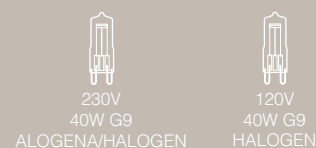
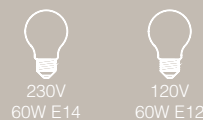
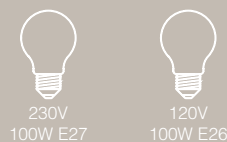
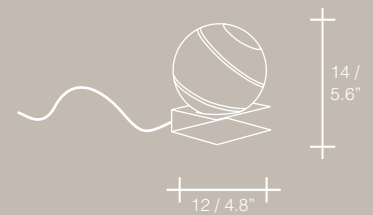
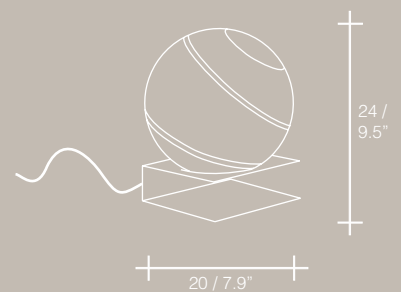
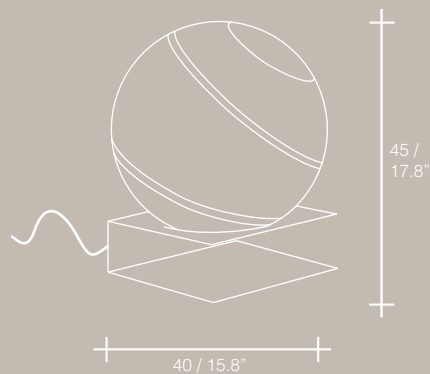

BIANCO
 WHITE



BIANCO
 WHITE



BIANCO
 WHITE



NERO
 BLACK



NERO
 BLACK





NERO
 BLACK

MISURE IN CM / POLLICI, PER AGGIORNAMENTI SUI DATI TECNICI RIFERIRSI AL LISTINO CORRENTE - MEAS. IN CM / INCHES, FOR UPDATED TECHNICAL DATA PLEASE REFER
 TO OUR CURRENT PRICE LIST. IL WATTAGGIO INDICATO È IL MASSIMO CONSENTITO SE NON INDICATO DIVERSAMENTE TRA PARENTESI - WATTAGE INDICATED IS MAXIMUM
 ALLOWED UNLESS DIFFERENTLY SPECIFIED IN BRACKETS.



G.R.A. GIROVAGHI, ROMANTICI ANELLI DI
LUCE. G.R.A. GYRATING ROMANTIC RINGS OF
LIGHT.

 **MODUL** 
ELECTRO
www.modulelectro.ru





MODUL
ELECTRO
www.modulelectro.ru



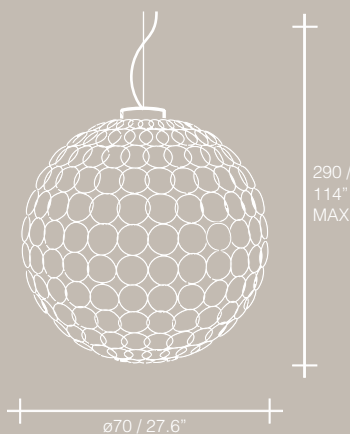

G.R.A. - DESIGN B. RINALDI
 SOSPENSIONE REALIZZATA SALDANDO A MANO
 400 ANELLI IN METALLO, PLACCATI NICHEL O DE-
 CORATI DA UN PREZIOSO RIVESTIMENTO FOGLIA
 ORO O ARGENTO. G.R.A. E' UNA GRANDE SFERA
 IMPONENTE E LEGGERA CHE INASPETTATAMEN-
 TE INONDA L'AMBIENTE DI LUCE E DI ELEGANTI
 INTRECCI DI OMBRE.
 OVER 400 HAND-SOLDERED METAL RINGS COM-
 PRISE G.R.A., AND YET DESPITE THE SIZE, IT IS
 AIRY AND LIGHT. G.R.A.'S SPHERICAL FORM AND
 INTRICATE LIGHT CREATE THE DELICATE ILLUSION
 OF MOVEMENT AS SHADOWS GLIDE ACROSS THE
 ROOM. A DRAMATIC PRESENCE IN ANY SPACE,
 G.R.A. IS AVAILABLE IN SILVER OR GOLD LEAF.

G.R.A. - DESIGN B. RINALDI
 SOSPENSIONE REALIZZATA SALDANDO A MANO
 300 ANELLI IN METALLO, PLACCATI NICHEL O DE-
 CORATI DA UN PREZIOSO RIVESTIMENTO FOGLIA
 ORO O ARGENTO. G.R.A. E' UNA GRANDE SFERA
 IMPONENTE E LEGGERA CHE INASPETTATAMEN-
 TE INONDA L'AMBIENTE DI LUCE E DI ELEGANTI
 INTRECCI DI OMBRE.
 OVER 300 HAND-SOLDERED METAL RINGS COM-
 PRISE G.R.A., AND YET DESPITE THE SIZE, IT IS
 AIRY AND LIGHT. G.R.A.'S SPHERICAL FORM AND
 INTRICATE LIGHT CREATE THE DELICATE ILLUSION
 OF MOVEMENT AS SHADOWS GLIDE ACROSS THE
 ROOM. A DRAMATIC PRESENCE IN ANY SPACE,
 G.R.A. IS AVAILABLE IN SILVER OR GOLD LEAF.

MODUL
 ELECTRO
www.modulelectro.ru



230V
 100W GZ10
 HPAR111
 ALOGENA/HALOGEN



120V
 100W R111
 GU10
 HALOGEN



230V
 100W GZ10
 HPAR111
 ALOGENA/HALOGEN



120V
 100W R111
 GU10
 HALOGEN



PLACCATO NICHEL
 NICKEL-PLATED



FOGLIA ORO
 GOLD LEAF

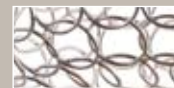

FOGLIA ARGENTO
 SILVER LEAF



PLACCATO NICHEL
 NICKEL-PLATED



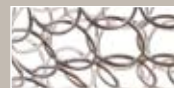

FOGLIA ORO
 GOLD LEAF



FOGLIA ARGENTO
 SILVER LEAF

GLAMOUR. LA LUCE CORTEGGIA L' OMBRA.
GLAMOUR. METAL LINKS OVERLAP SEDUCTIVELY.

 **MODUL** 
ELECTRO
www.modulelectro.ru



 **MODUL**
ELECTRO
www.modulelectro.ru





MODUL
ELECTRO
www.modulelectro.ru







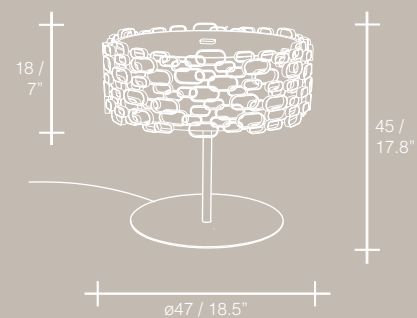
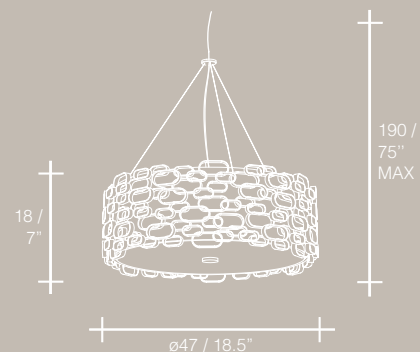

MODUL
ELECTRO
www.modul-electro.ru



GLAMOUR - DESIGN D. ARSLAN
 SOSPENSIONE DELINEATA DA UNA FASCIA DI SEZIONI METALLICHE SAPIENTEMENTE SALDATE A MANO UNA AD UNA, IN FINITURA ORO 24K, NICHEL O BIANCO. GLAMOUR RICORDA UN GIOIELLO FEMMINILE, APPARISCENTE E SOFISTICATO, CHE REGALA ALL'AMBIENTE UNA RICCHEZZA DI LUCE E DI ELEGANTI DETTAGLI.
 LIKE A UNIQUE PIECE OF JEWELRY FOR THE HOME, GLAMOUR'S ROWS OF INDIVIDUALLY HAND-SOLDERED METAL LINKS RECALL A SUPPLICATED NECKLACE. FINISHED IN 24K GOLD, NICKEL OR WHITE, GLAMOUR ELEGANTLY DETAILING ANY LIVING SPACE. AS A SUSPENSION LAMP, GLAMOUR'S METAL LINKS OVERLAP SEDUCTIVELY WHILE PROVIDING A ROMANTIC LIGHT.

GLAMOUR - DESIGN D. ARSLAN
 LAMPADA DA TAVOLO DELINEATA DA UNA FASCIA DI SEZIONI METALLICHE SAPIENTEMENTE SALDATE A MANO UNA AD UNA, IN FINITURA ORO 24K, NICHEL O BIANCO. GLAMOUR RICORDA UN GIOIELLO FEMMINILE, APPARISCENTE E SOFISTICATO, CHE REGALA ALL'AMBIENTE UNA RICCHEZZA DI LUCE E DI ELEGANTI DETTAGLI.
 LIKE A UNIQUE PIECE OF JEWELRY FOR THE HOME, GLAMOUR'S ROWS OF INDIVIDUALLY HAND-SOLDERED METAL LINKS RECALL A SUPPLICATED NECKLACE. FINISHED IN 24K GOLD, NICKEL OR WHITE, GLAMOUR ELEGANTLY DETAILING ANY LIVING SPACE. AS A TABLE LAMP, GLAMOUR'S METAL LINKS OVERLAP SEDUCTIVELY WHILE PROVIDING A ROMANTIC LIGHT.

 230V
 3 X 40W E14 (MAX 3 X 60W E14)
 120V
 3 X 40W E12 (MAX 3 X 60W E12)

 230V
 3 X 40W E14 (MAX 3 X 60W E14)
 120V
 3 X 40W E12 (MAX 3 X 60W E12)



PLACCATO ORO 24K
24K GOLD-PLATED



PLACCATO NICHEL
NICKEL-PLATED



BIANCO
WHITE



PLACCATO ORO 24K
24K GOLD-PLATED





PLACCATO NICHEL
NICKEL-PLATED



BIANCO
WHITE

MODULO
 ELECTRO
www.modulelectro.ru

J'ADORE VENICE, ILLUMINA ANGOLI SEGRETI.
J'ADORE VENICE, ILLUMINATING SECRET CORNERS.



 **MODUL** 
ELECTRO
www.modulelectro.ru





MODUL
ELECTRO
www.modulelectro.ru



 **MODUL** 
ELECTRO
www.modulelectro.ru



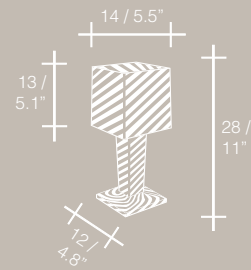
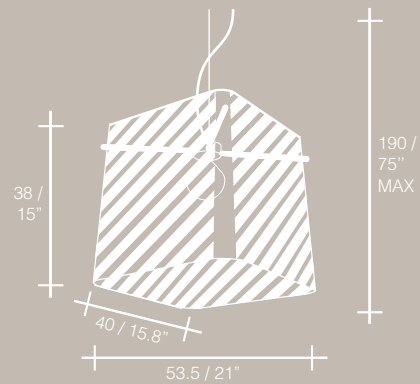

J'ADORE VENICE - DESIGN B. RAINALDI
 SOSPENSIONE IN VETRO TRASPARENTE DECO-
 RATO DA UN RAFFINATO GRAFISMO DI RIGHE
 BIANCHE O NERE. LA LUCE FILTRA ATTRAVERSO
 LE TRASPARENZE E ILLUMINA UNIFORMEMENTE
 L'AMBIENTE MENTRE LE RIGHE RICREANO UN
 MOTIVO ANTICO CHE DONA A J'ADORE VENICE
 UN ANIMO SOGNATORE E ROMANTICO.
 CONNECTING THE PAST AND THE PRESENT, THE
 ROMANTIC ESSENCE OF J'ADORE VENICE IS
 REPRESENTED IN THIS SUSPENSION LIGHT BY
 THIS ANCIENT IMAGE ETCHED IN TRANSPARENT
 GLASS. LIGHT FILTERING AROUND THIS IMAGE,
 AVAILABLE IN WHITE OR BLACK, UNIFORMLY
 ILLUMINATES THE SPACE.

J'ADORE VENICE - DESIGN B. RAINALDI
 LAMPADA DA TAVOLO IN VETRO TRASPARENTE DE-
 CORATO DA UN RAFFINATO GRAFISMO DI RIGHE
 BIANCHE O NERE. LA LUCE FILTRA ATTRAVERSO
 LE TRASPARENZE E ILLUMINA UNIFORMEMENTE
 MENTRE LE RIGHE RICREANO UN MOTIVO ANTICO
 CHE DONA A J'ADORE VENICE UN ANIMO SOGNA-
 TORE E ROMANTICO.
 CONNECTING THE PAST AND THE PRESENT, THE
 ROMANTIC ESSENCE OF J'ADORE VENICE IS
 REPRESENTED IN THIS TABLE LIGHT BY THIS AN-
 CIENT IMAGE ETCHED IN TRANSPARENT GLASS.
 LIGHT FILTERING AROUND THIS IMAGE, AVAILA-
 BLE IN WHITE OR BLACK, UNIFORMLY ILLUMINATES
 THE SPACE.

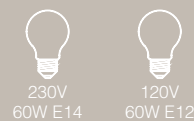
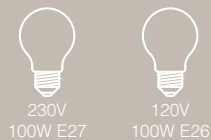

BIANCO
 WHITE



NERO
 BLACK





BIANCO
 WHITE



NERO
 BLACK

MODUL
 ELECTRO
www.modulelectro.ru

TRESOR, SI ADAGIA LANGUIDAMENTE ALLE
PARETI. TRESOR, VIBRANT WALL LIGHTING.

 **MODUL** 
ELECTRO
www.modulelectro.ru



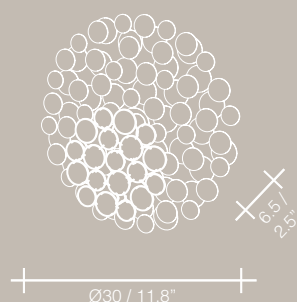
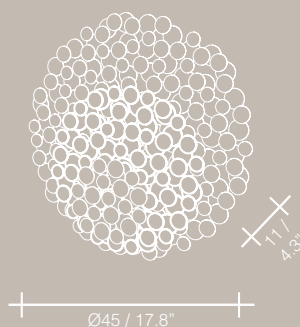

TRESOR - DESIGN J.F. CROCHET
LAMPADA DA PARETE COMPOSTA DA 3 DISCHI
DI PREZIOSE MONETINE IN METALLO SALDATE
TRA LORO E RIVESTITE ARTIGIANALMENTE CON
FOGLIA ORO O ARGENTO. CON LA SUA RAFFINA-
TEZZA TRESOR DONA ELEGANZA ALL'AMBIENTE,
IMPREZIOSISCE LA PARETE E LA RIVESTE DI
EMOZIONANTI AUREOLE DI LUCE.

AN IMPECCABLE ACCENT TO ANY SPACE,
TRESOR'S HAND MADE DESIGN AND PRECIOUS
METAL COINS CREATE SCINTILLATING HALOS OF
LIGHT. FINISHED IN GOLD OR SILVER LEAF, AND IN
SIZES OF EITHER TWO OR THREE DISKS, TRESOR
WORKS IN ANY SPACE, ADDING A TOUCH OF
ELEGANCE.

TRESOR - DESIGN J.F. CROCHET
LAMPADA DA PARETE COMPOSTA DA 2 DISCHI
DI PREZIOSE MONETINE IN METALLO SALDATE
TRA LORO E RIVESTITE ARTIGIANALMENTE CON
FOGLIA ORO O ARGENTO. CON LA SUA RAFFINA-
TEZZA TRESOR DONA ELEGANZA ALL'AMBIENTE,
IMPREZIOSISCE LA PARETE E LA RIVESTE DI
EMOZIONANTI AUREOLE DI LUCE.

AN IMPECCABLE ACCENT TO ANY SPACE, TRE-
SOR'S HAND MADE DESIGN AND PRECIOUS METAL
COINS CREATE SCINTILLATING HALOS OF LIGHT.
FINISHED IN GOLD OR SILVER LEAF, AND IN SIZES
OF EITHER TWO OR THREE DISKS, TRESOR WORKS
IN ANY SPACE, ADDING A TOUCH OF ELEGANCE.

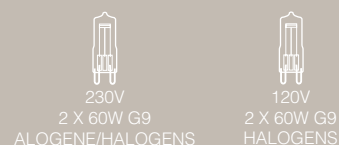

FOGLIA ORO
GOLD LEAF



FOGLIA ORO
GOLD LEAF



FOGLIA ARGENTO
SILVER LEAF





FOGLIA ARGENTO
SILVER LEAF

MODULO
ELECTRO
www.modulelectro.it





ETOILE, BRILLA NEL CIELO DELLA STANZA.
ETOILE, TWINKLING IN AN INDOOR SKY.

 **MODUL** 
ELECTRO
www.modulelectro.it

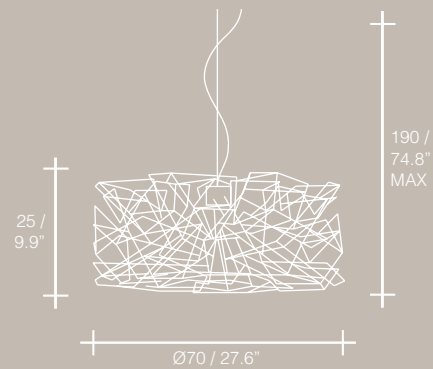



ETOILE - DESIGN C. LAVA
 SOSPENSIONE FORMATA DA UN INTRECCIO DI
 SOTTILI BRACCI METALLICI PLACCATI NICHEL.
 ETOILE E' UN INTRIGANTE E INSOLITO OGGET-
 TO CELESTE NELLA STANZA, BRILLA DI LUCE
 PROPRIA E LA EMANA TUTTO INTORNO CREANDO
 LEGGERE SEDUZIONI D'OMBRA CHE IMPREZIOSI-
 SCONO L'AMBIENTE.
 A CELESTIAL SUSPENSION OF INTERWOVEN
 NICKEL-PLATED METAL SHAFTS, ETOILE TWINKLES
 IN ALL DIRECTIONS CREATING A GENTLE PLAY OF
 LIGHT AND SHADOW FOR ANY SPACE.

 230V 8 X 10W G4 12V 8 X 20W G4 12V ALOGENE/HALOGENS	 120V 8 X 10W G4 12V 8 X 20W G4 12V HALOGENS
---	---



PLACCATO NICHEL
 NICKEL-PLATED

MODUL
 ELECTRO
www.modulselectro.ru

MISURE IN CM / POLLICI, PER AGGIORNAMENTI SUI DATI TECNICI RIFERIRSI AL LISTINO CORRENTE - MEAS. IN CM / INCHES, FOR UPDATED TECHNICAL DATA PLEASE REFER
 TO OUR CURRENT PRICE LIST. IL WATTAGGIO INDICATO È IL MASSIMO CONSENTITO SE NON INDICATO DIVERSAMENTE TRA PARENTESI - WATTAGE INDICATED IS MAXIMUM
 ALLOWED UNLESS DIFFERENTLY SPECIFIED IN BRACKETS.





EVERYTHING IS LIGHT



TERZANI SPA
VIA CASTELPULCI INT.9 50018 SCANDICCI (FIRENZE) ITALY
TEL. +39 055 722021 FAX +39 055 7311161
N.VERDE 800-018575 TERZANI@TERZANI.COM

TERZANI USA, INC.
11470 INTERCHANGE CIRCLE NORTH MIRAMAR, FL 33025
PH. 954-438 7779 FAX 954-438 7566
1 (866) 380-5412 TERZANIUSA@TERZANI.COM

© TERZANI 2009

CREATIVE DIRECTION COSIMO TERZANI
PHOTOS LEONARDO BEGLIERI
PRINTED IN EU (ITALY) 2009

WWW.TERZANI.COM

 **MODUL** 
ELECTRO
www.modulelectro.ru

MODUL

WWW.TERZANI.COM
ELECTRO

www.modulelectro.ru

TERZANI
LA LUCE PENSATA

EVERYTHING IS LIGHT